

CLAYTON OFF ROAD  
COR-3010025  
JEEP GLADIATOR 2.5" OVERLAND + LIFT KIT (2020 & UP, JT)

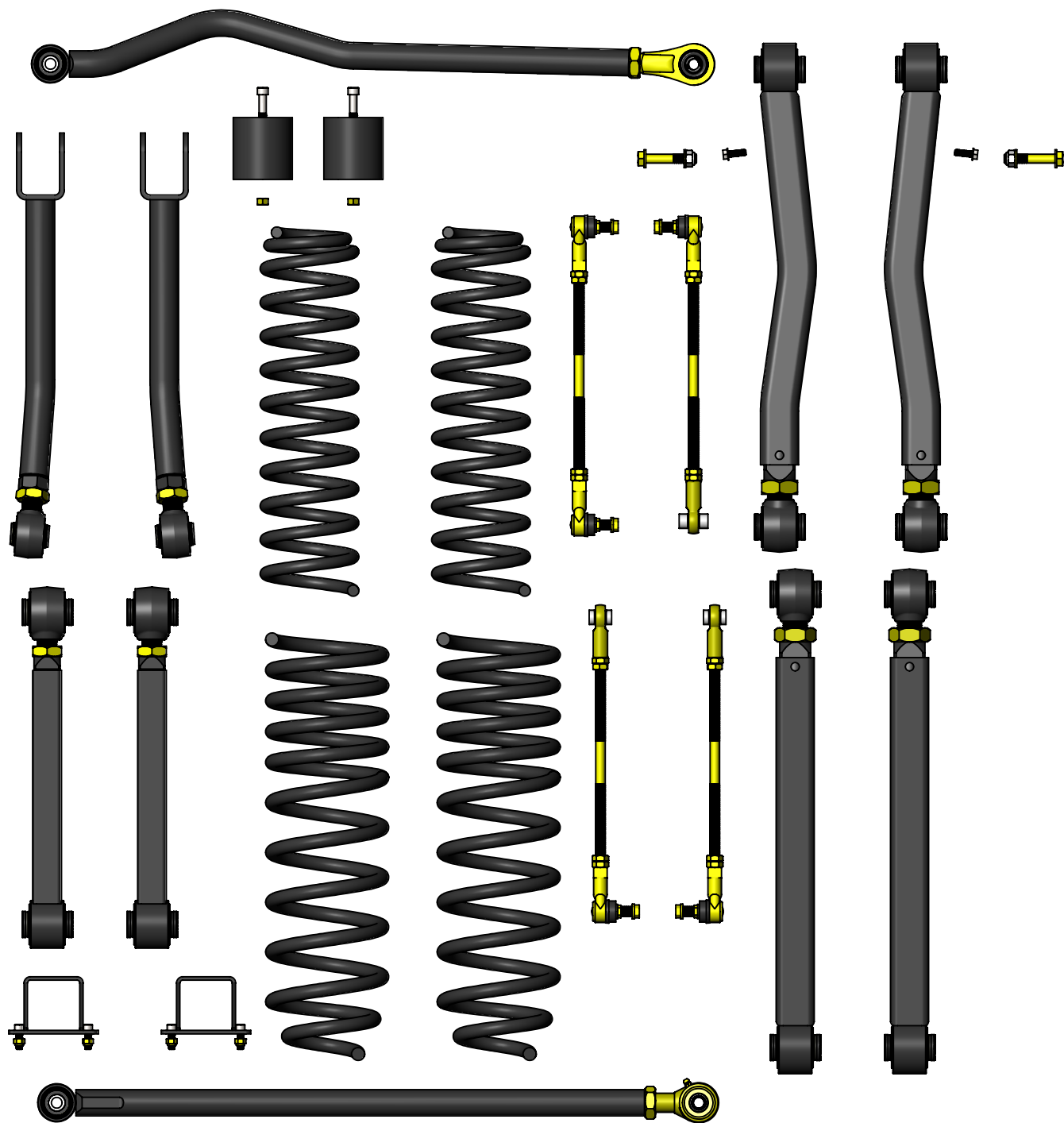

NOTES: This product may require general welding, fabrication and automotive mechanic skills. Welding should only be done by a competent welder. Clayton Off Road implies no guarantees or warranties and is not liable for improper installation. Some grinding and fitment may be required when installing this product. Every vehicle varies slightly and some fabrication may be required.

Recommended starting lengths for track bars and control arms. These lengths can be adjusted as needed for caster angle, drive shaft angles and tire clearance. Please make sure to not exceed the maximum length of the control arms or track bars.

<b>Lift Height &gt;</b>	<b>Stock</b>	<b>2.5" Lift</b>	<b>3.5" Lift</b>
<b>Suspension Component</b>			
<b>Front Lower Control Arms</b>	24.000	24.336	24.500
<b>Front Upper Control Arms</b>	20.185	20.272	20.401
<b>Rear Lower Control Arms</b>	23.740	23.962	24.116
<b>Rear Upper Control Arms</b>	16.378	16.577	16.759
<b>Front Track Bar</b>	33.779	34.090	34.251
<b>Rear Track Bar</b>	33.689	33.869	33.987

Refer to individual product part number instructions.

Step 1: Position front of vehicle on jack stands or complete vehicle on lift.

Step 2: Support front axle.

Step 3: Remove front tires.

Step 4: Loosen front track bar bolts.

Step 5: Remove heat shields and loosen upper and lower control arm bolts.

Step 6: Loosen front upper and lower control arm bolts.

Step 7: Remove front sway bar links.

Step 8: Remove front shocks.

Step 9: Remove two brake line clip bolts on both sides.

Step 10: Unclip and disconnect all wires going to the front axle.

Step 11: Lower front axle.

Step 12: Remove front springs.

Step 13: Remove front upper and lower control arms on one side.

Step 14: Install front lower control arm part number COR-1709100 with curve facing in for tire clearance.

Step 15: Install front upper control arm part number COR-1709101 with curve away from the frame.

Step 16: Repeat steps 13 and 15 on other side.

Step 17: Remove front track bar.

Step 18: Install front track bar part number COR-4509100.

Step 19: Install front bump stops part number COR-1408100.

Step 20: Install front springs part number COR-1509350 2.5" lift or COR-1509450 3.5" lift.

Step 21: Install front shocks.

Step 22: Install front sway bar links part number COR-5109100.

Step 23: Clip and connect all wires going to the front axle.

Step 24: Install front tires.

Step 25: Position rear of vehicle on jack stands or complete vehicle on lift.

Step 26: Support rear axle.

Step 27: Remove rear tires.

Step 28: Loosen rear track bar bolts.

Step 29: Loosen rear upper and lower control arm bolts.

Step 30: Unclip or unbolt any brake lines or e-brake cables to let axle drop down more.

Step 31: Unclip and disconnect all wires going to the rear axle to let axle drop down more.

Step 32: Remove rear sway bar links.

Step 33: Remove rear shocks.

Step 34: Lower rear axle.

Step 35: Remove rear springs.

Refer to individual product part number instructions.

Step 36: Remove rear upper and lower control arms on one side.

Step 37: Install rear lower control arm part number COR-1710102 .

Step 38: Install rear upper control arm part number COR-1710103.

Step 39: Repeat steps 37 and 39 on other side.

Step 40: Remove rear track bar.

Step 41: Install rear track bar part number COR-4510110.

Step 42: Install rear bump stops part number COR-1410200.

Step 43: Install rear springs part number COR-1510251 2.5" lift or COR-1510351 3.5" lift.

Step 44: Install rear shocks.

Step 45: Install rear sway bar links part number COR-5110110.

Step 46: If removed install brake line clip bolts on both sides and bolt in parking brake cables.

Step 47: If unclipped or disconnected clip and connect all wires going to the rear axle.

Step 48: Install rear tires.

Step 50: With vehicle sitting at ride height center both front and rear axles under the vehicle by adjusting the front and rear track bars.

Step 51: In the next 2 steps it is very important to set the caster and pinion angle with a jack with the bolts at one end removed then adjust the length of the upper control arms so they are loaded up equally when the jack is removed.

Step 52: Adjust length of front upper arms to have a caster angle of 4.8 degrees. This angle should be within plus or minus 1.00 degrees.

Step 53: Adjust rear pinion angle to keep lower spring perches aligned with upper spring perches. On 2 door models it will be necessary to roll the pinion up to avoid the rear drive shaft from binding on full droop.

Step 54: Tighten all track bar and control arm bolts.

Step 55: Tighten all track bar and control arm jam nuts.

Clayton Off Road  
COR-1709100  
Jeep Overland + Front Lower Control Arms (2018 & Up, JL/JT)



NOTES: This product may require general welding, fabrication and automotive mechanic skills. Welding should only be done by a competent welder. Clayton Off Road implies no guarantees or warranties and is not liable for improper installation. Some grinding and fitment may be required when installing this product. Every vehicle varies slightly and some fabrication may be required.

Refer to pictures below.

Step 1: Remove old control arm on one side.

Step 2: Remove shock bolt.

Step 3: Position axle.

Step 4: Measure length from axle side mount to frame side mount.

Step 5: Adjust control arm to length and run jam nut up to control arm tube insert.

Step 6: Install new control arm with adjustment end on frame.

Step 7: Install control arm bolts and nuts.

Step 8: Torques both bolts to 190 ft-lb.

Step 9: Tighten jam nut using a 46mm or 1-13/16" wrench.

Step 10: Bolt brake line clip to control arm.

Step 11: Install new shock bolt, nut and washers.

Step 12: Repeat steps 1 to 11 on other side.

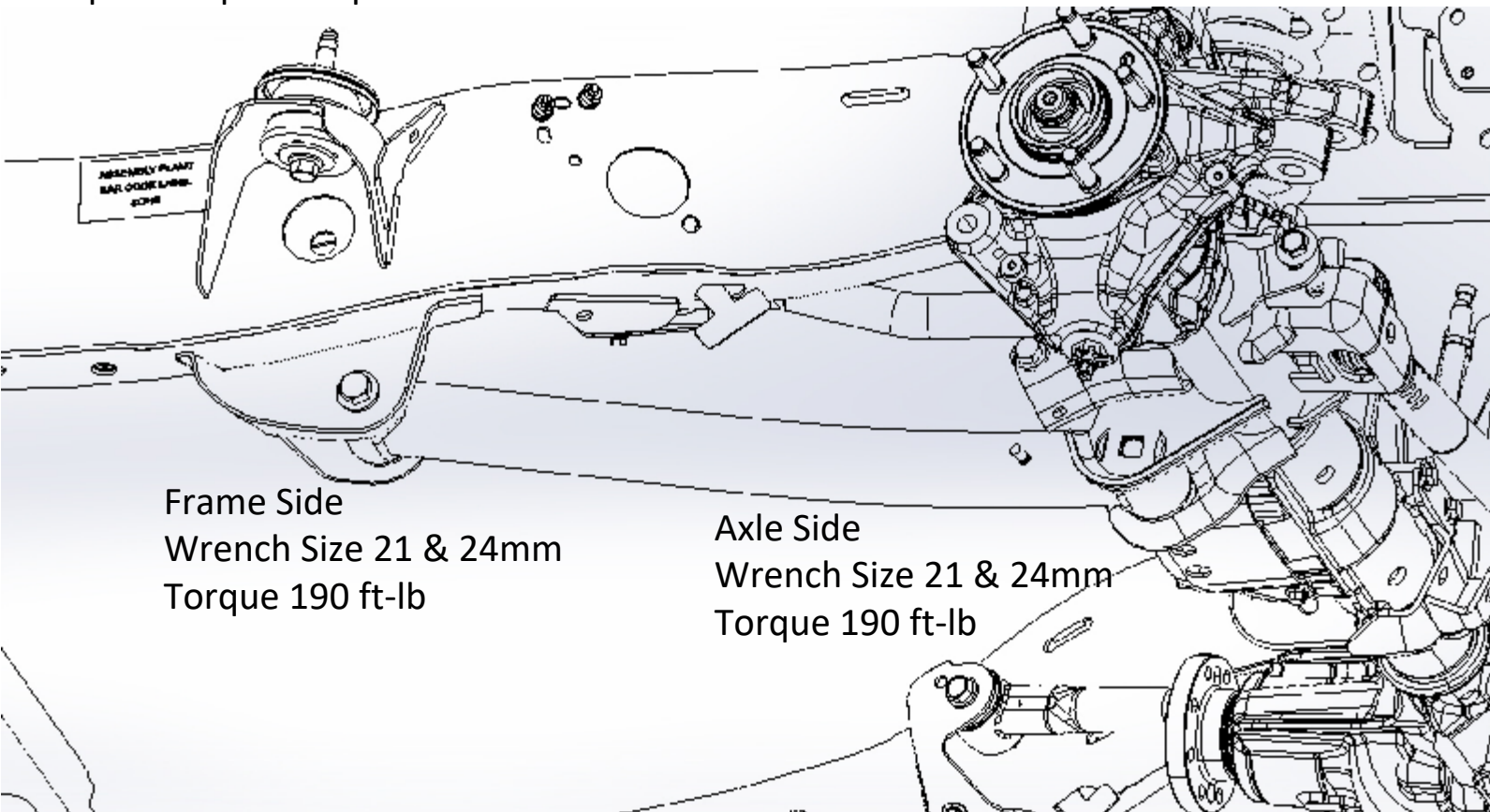

Frame Side  
Wrench Size 21 & 24mm  
Torque 190 ft-lb

Axle Side  
Wrench Size 21 & 24mm  
Torque 190 ft-lb

Refer to drawing below for minimum and maximum lengths.

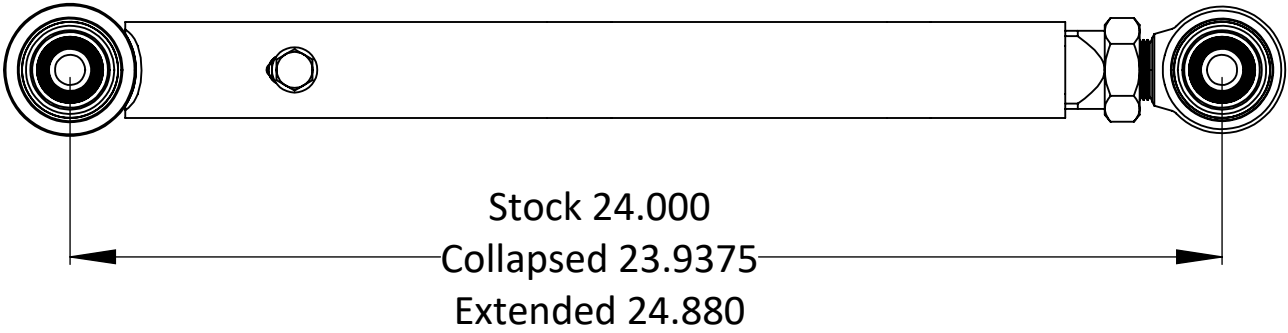

**Clayton Off Road  
COR-1709101  
Jeep Overland + Front Upper Control Arms (2018 & Up, JL/JT)**



NOTES: This product may require general welding, fabrication and automotive mechanic skills. Welding should only be done by a competent welder. Clayton Off Road implies no guarantees or warranties and is not liable for improper installation. Some grinding and fitment may be required when installing this product. Every vehicle varies slightly and some fabrication may be required.



Refer to pictures below.

Step 1: Support axle from rotating, a floor or bottle jack works well.

Step 2: Remove old control arms.

Step 3: Set caster to 4.5 to 5.5 degrees by adjusting the height of the jack.

Step 4: Install arms at frame side, arm should bow away from frame.

Step 5: Adjust control arm to length so that bolts can easily be installed at axle end.

Step 6: Remove jack, and check caster.

Step 7: Torque all bolts to 80 ft-lb.

Step 8: Tighten jam nut using a 1-7/16" wrench

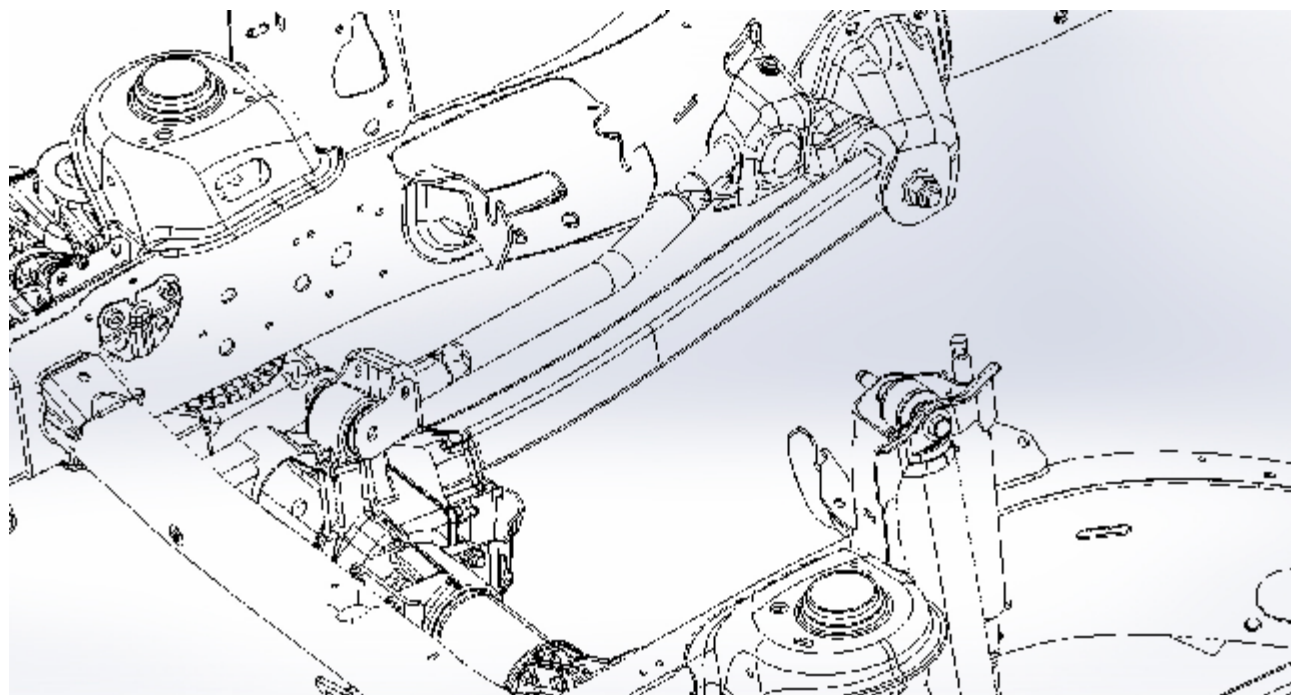
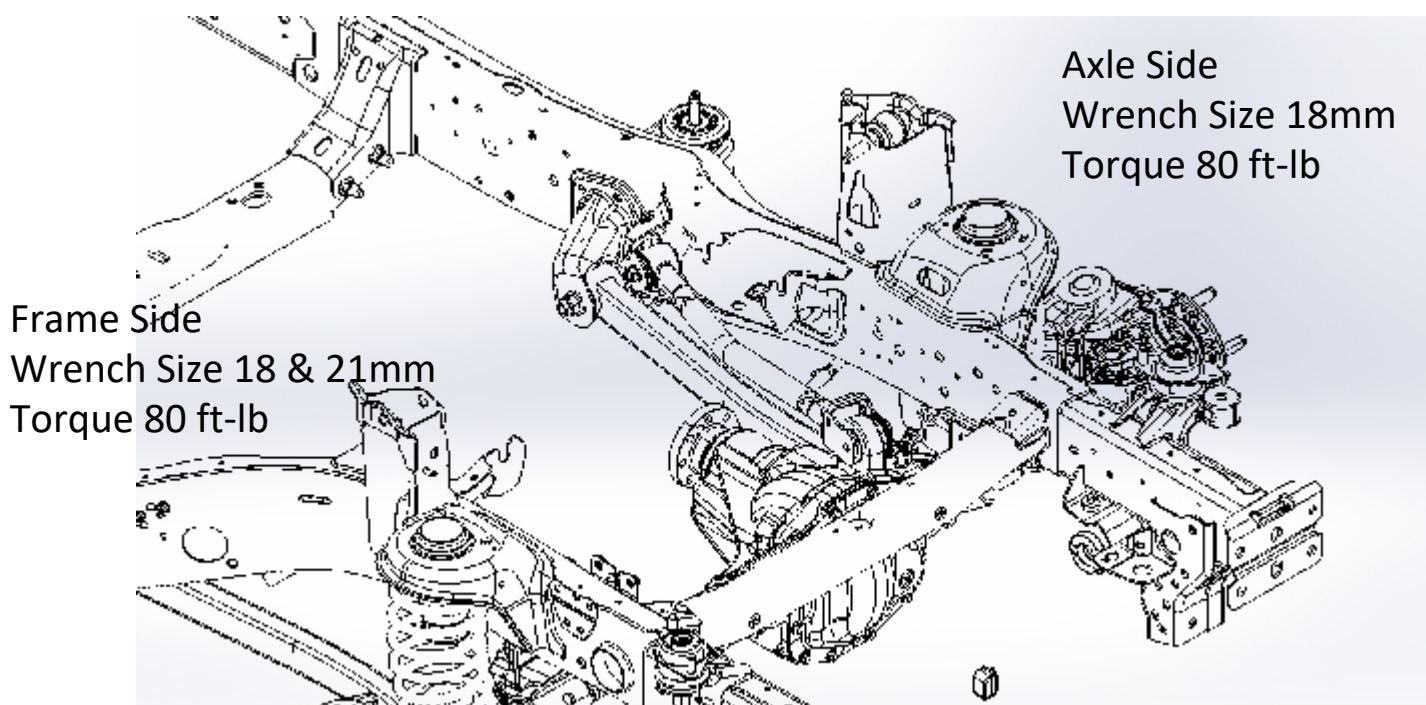

Refer to drawing below for minimum and maximum lengths.

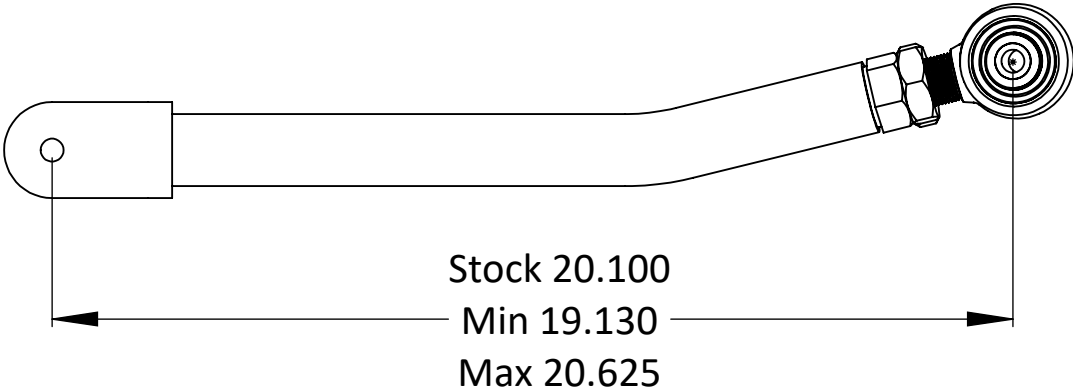

**Clayton Off Road  
COR-4509100  
Jeep Adjustable Front Track Bar (2018 & Up, JL/JT)**



NOTES: This product may require general welding, fabrication and automotive mechanic skills. Welding should only be done by a competent welder. Clayton Off Road implies no guarantees or warranties and is not liable for improper installation. Some grinding and fitment may be required when installing this product. Every vehicle varies slightly and some fabrication may be required.

Refer to pictures below.

Step 1: Remove old track bar.

Step 2: Center frame on axle.

Step 3: Measure length from axle side mount to frame side mount.

Step 4: Adjust track bar to length and run jam nut up to track bar tube.

Step 5: Install new track bar with adjustment end on axle.

Step 6: Install track bar bolts and nuts.

Step 7: Torques both bolts to 110 ft-lb.

Step 8: Tighten jam nut using a 1-7/16" wrench.

Step 9: Make sure Johnny Joint at frame side is centered in bracket.

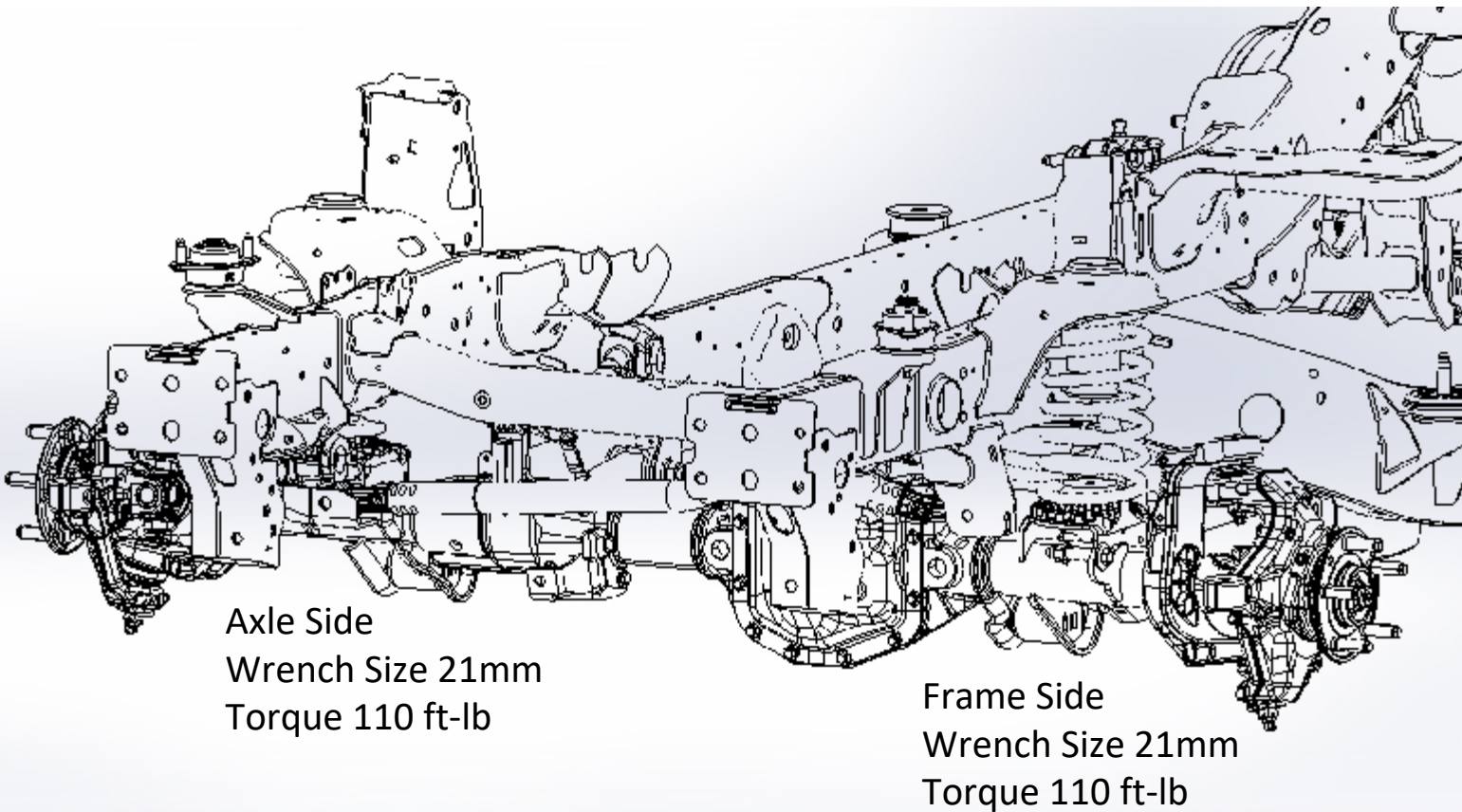

Refer to drawing below for minimum and maximum lengths.

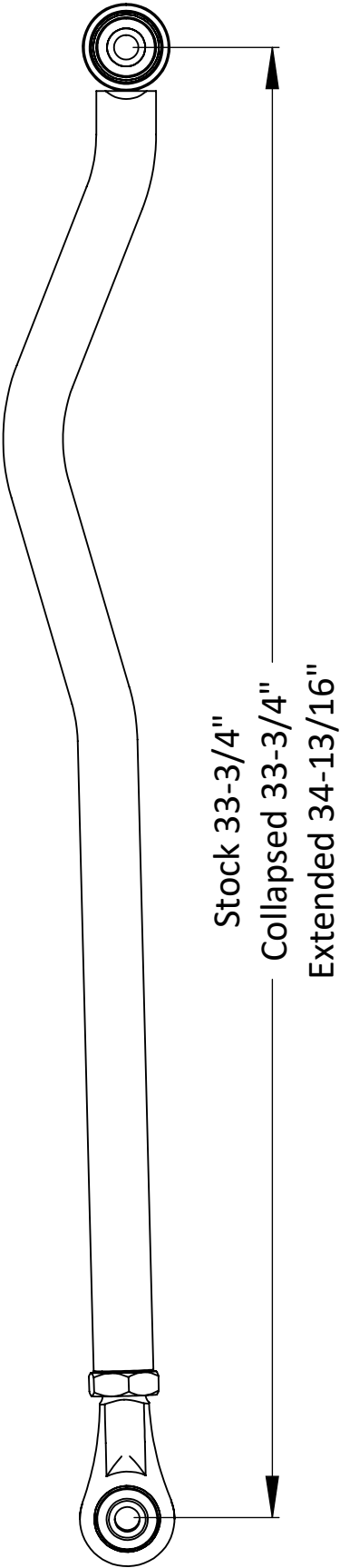

Clayton Off Road  
COR-1408100  
Jeep Front Bump Stops (2007 & Up, JK/JL/JT)



NOTES: This product may require general welding, fabrication and automotive mechanic skills. Welding should only be done by a competent welder. Clayton Off Road implies no guarantees or warranties and is not liable for improper installation. Some grinding and fitment may be required when installing this product. Every vehicle varies slightly and some fabrication may be required.

Refer to picture below.

Step 1: Remove spring.

Step 2: Center bump stop on lower coil bucket.

Step 3: Mark hole location on lower coil bucket.

Step 4: Drill 13/32" hole in lower coil bucket or use existing hole.

Step 5: Insert bump stop into spring and install spring.

Step 6: Install nut and tighten bolt.



Clayton Off Road  
COR-5109100  
Jeep Adjustable Front Sway Bar End Links (2018 & Up, JL/JT)

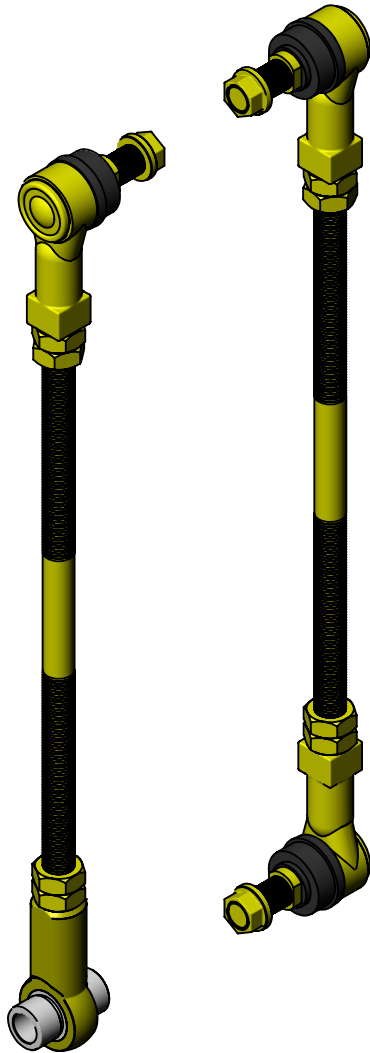

NOTES: This product may require general welding, fabrication and automotive mechanic skills. Welding should only be done by a competent welder. Clayton Off Road implies no guarantees or warranties and is not liable for improper installation. Some grinding and fitment may be required when installing this product. Every vehicle varies slightly and some fabrication may be required.



Refer to pictures below.

Step 1: Remove old sway bar end links.

Step 2: Drill hole in sway bar to 1/2" diameter.

Step 3: Make sure vehicle is at ride height.

Step 4: Set sway bar at a 5 degree upward angle.

Step 5: Measure the distance from the upper and lower mounting holes.

Step 6: Use the formula below to calculate rod length.

Step 7: Cut rod to length.

Step 8: Install two jam nuts on each end of rod.

Step 9: It may be necessary to lock the 2 jam nuts against each other to thread rod end on.

Step 10: The rod end with no stud in it goes on the passenger side axle, Use an aluminum spacer on each side of this rod end.

Step 11: Install sway bar links with the studs facing in.

Step 12: Make sure all rod ends are centered.

Step 13: Torque all nuts, bolts and jam nuts to 60 ft-lb.

Step 14: Cycle the suspension through its full travel, check for binding and adjust rod length if needed.

Step 15: Do not exceed maximum length

Step 16: Make sure to keep at least 3/4" of thread engagement with rod end.

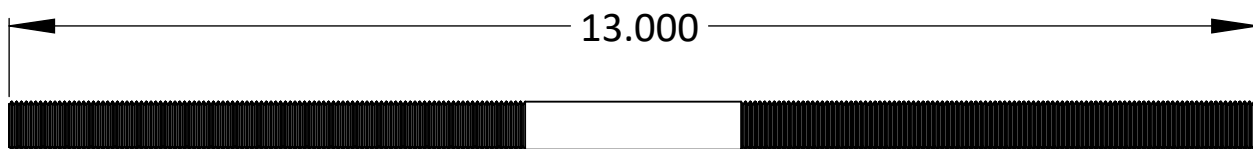

### Sway bar link rod length calculation

Take the center distance and subtract 2.625" from it, this is the rod length.

Subtract the rod length from 13.000" and divide it by 2.

This is the length to cut from each end of the rod.

Another option is to measure the stock sway bar link and add the amount of lift you are using to this dimension, then use the calculation above.

Refer to drawing below for minimum and maximum lengths.

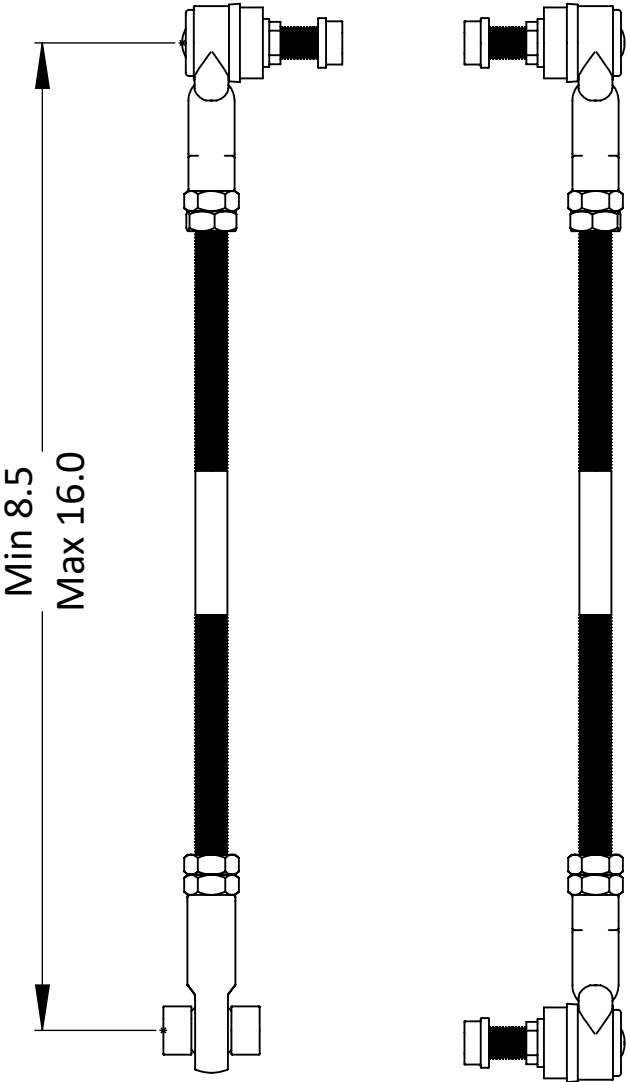

Clayton Off Road  
COR-1710102  
Jeep Gladiator Overland + Rear Lower Control Arms (2020 & Up, JT)



NOTES: This product may require general welding, fabrication and automotive mechanic skills. Welding should only be done by a competent welder. Clayton Off Road implies no guarantees or warranties and is not liable for improper installation. Some grinding and fitment may be required when installing this product. Every vehicle varies slightly and some fabrication may be required.

Refer to pictures below.

Step 1: Remove old control arm on one side.

Step 2: Position axle.

Step 3: Measure length from axle side mount to frame side mount.

Step 4: Adjust control arm to length and run jam nut up to control arm tube insert.

Step 5: Install new control arm with adjustment end on frame.

Step 6: Install control arm bolts and nuts.

Step 7: Torques both bolts to 190 ft-lb.

Step 8: Tighten jam nut using a 46mm or 1-13/16" wrench.

Step 9: Repeat steps 1 to 9 on other side.

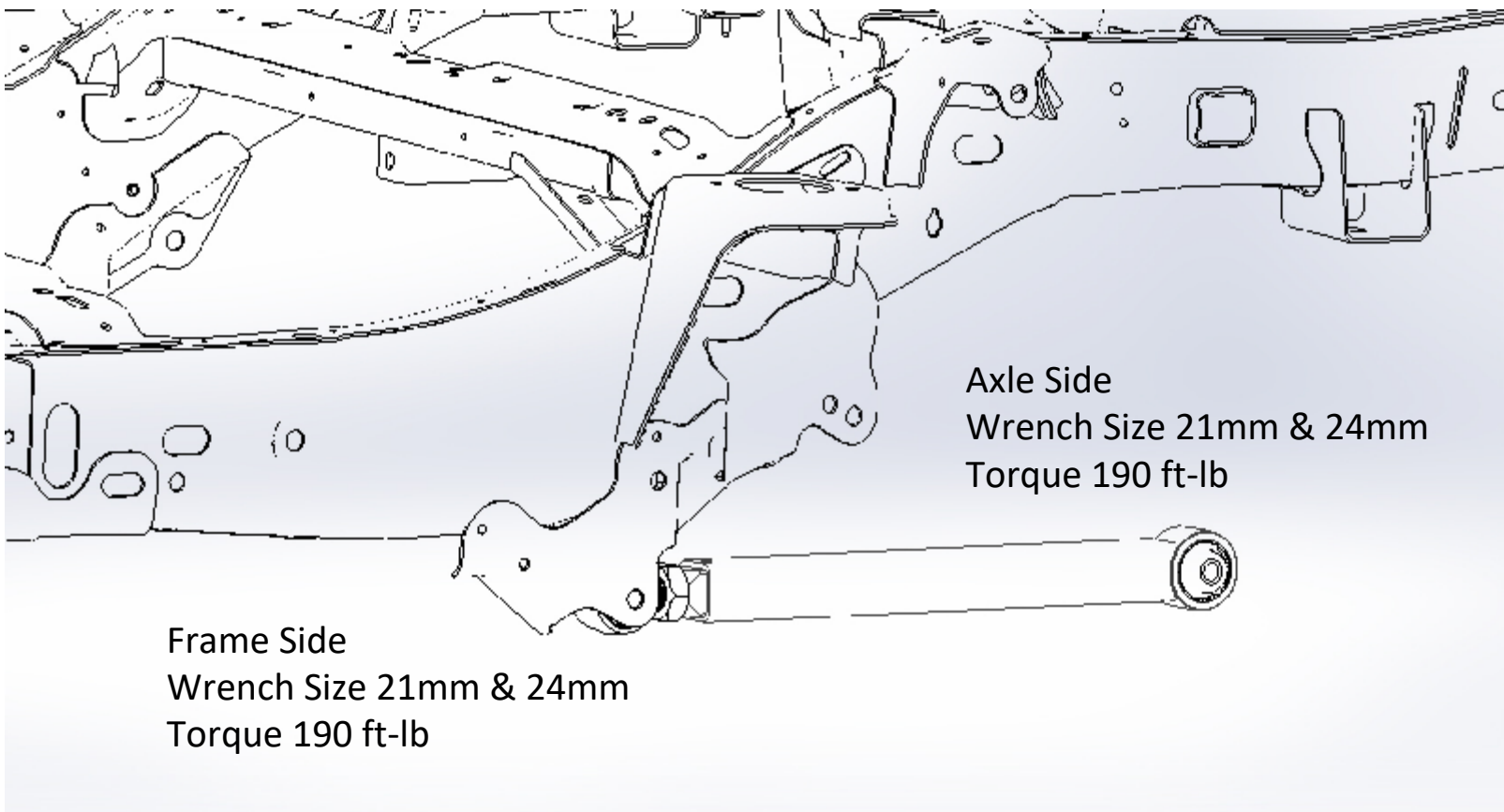

Refer to drawing below for minimum and maximum lengths.

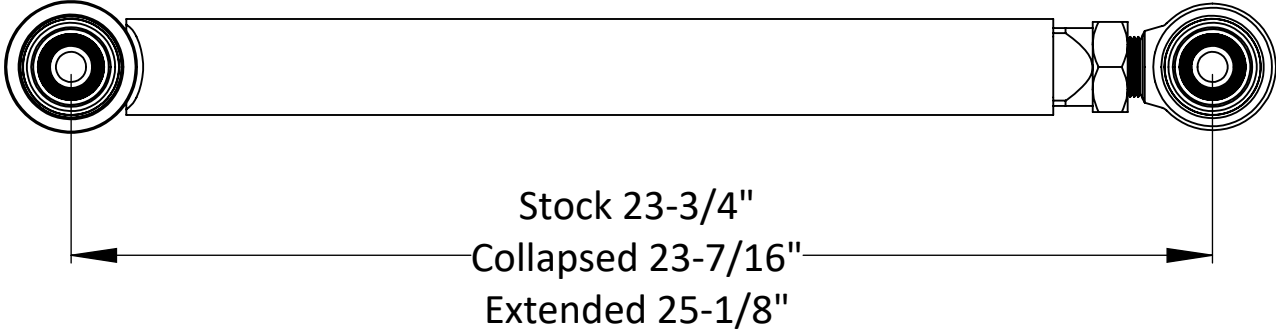

Clayton Off Road  
COR-1710103  
Jeep Gladiator Overland + Rear Upper Control Arms (2019 & Up, JT)



NOTES: This product may require general welding, fabrication and automotive mechanic skills. Welding should only be done by a competent welder. Clayton Off Road implies no guarantees or warranties and is not liable for improper installation. Some grinding and fitment may be required when installing this product. Every vehicle varies slightly and some fabrication may be required.

Refer to pictures below.

Step 1: Support axle from rotating, a floor or bottle jack works well.

Step 2: Remove old control arms.

Step 3: Set pinion angle desired pinion angle by adjusting the height of the jack.

Step 4: Install arms at frame side with adjuster at frame side.

Step 5: Adjust control arm to length so that bolts can easily be installed at axle end.

Step 6: Remove jack, and pinion angle.

Step 7: Torque all bolts to 190 ft-lb.

Step 8: Tighten jam nut using a 1-7/16" wrench.

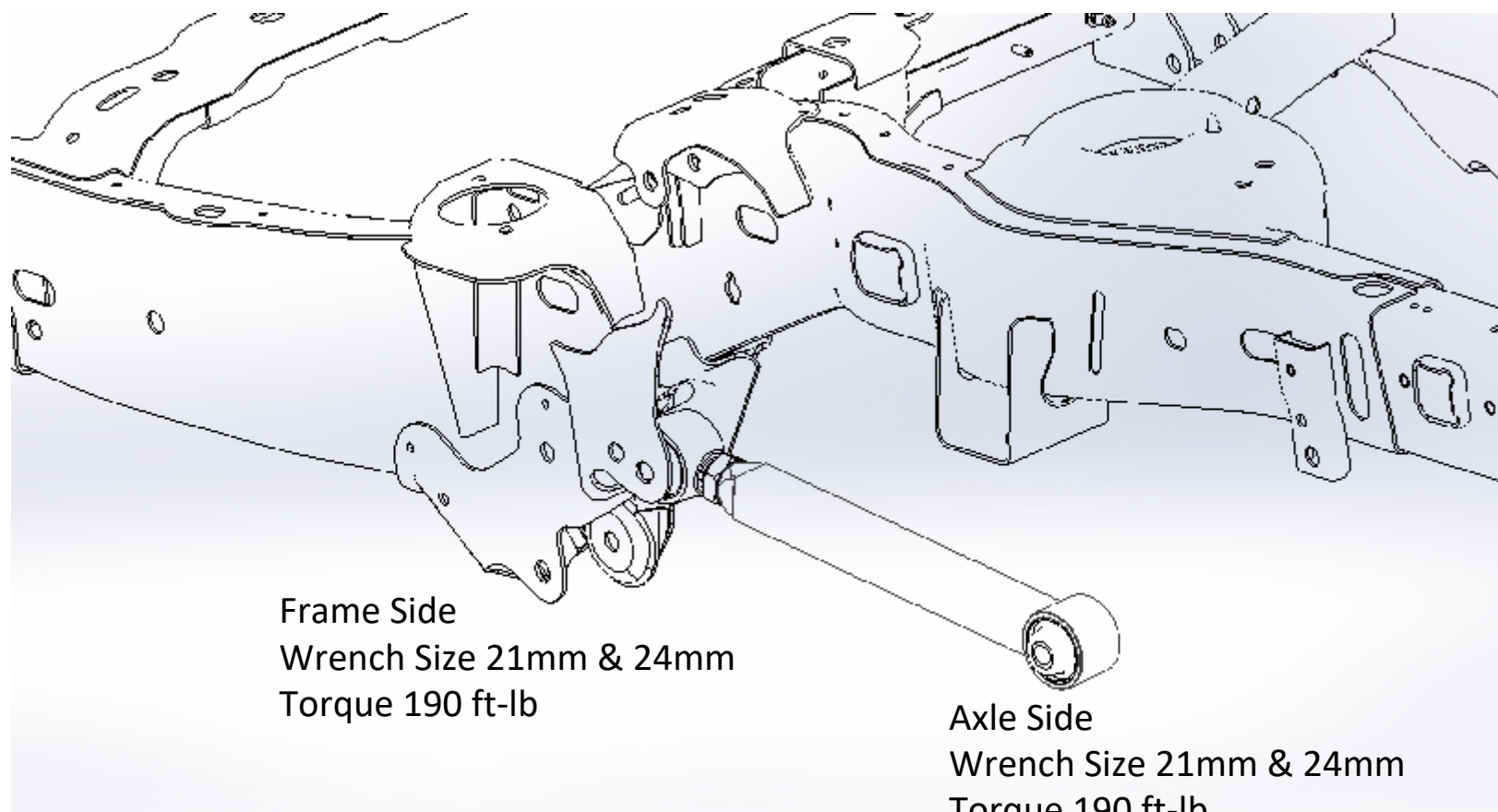

Frame Side  
Wrench Size 21mm & 24mm  
Torque 190 ft-lb

Axle Side  
Wrench Size 21mm & 24mm  
Torque 190 ft-lb

Refer to drawing below for minimum and maximum lengths.

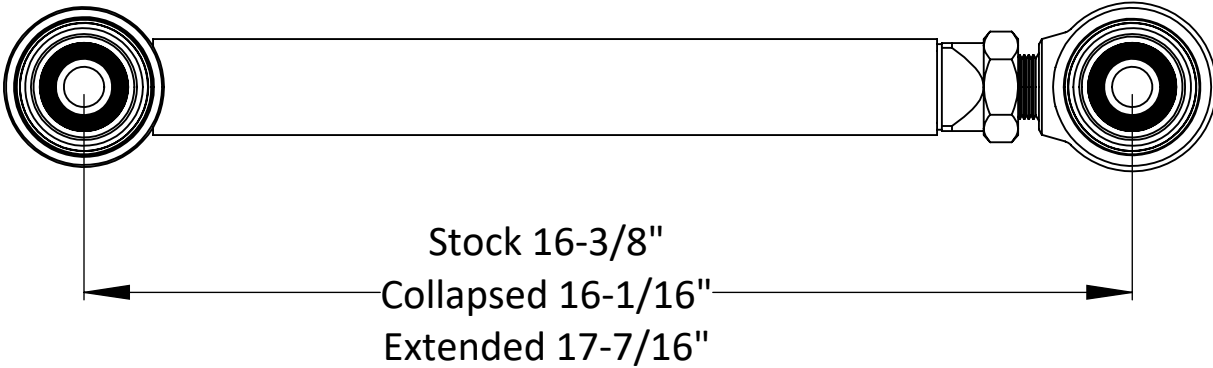



**Clayton Off Road  
COR-4510110  
Jeep Gladiator Adjustable Rear Track Bar (2020 & Up, JT)**

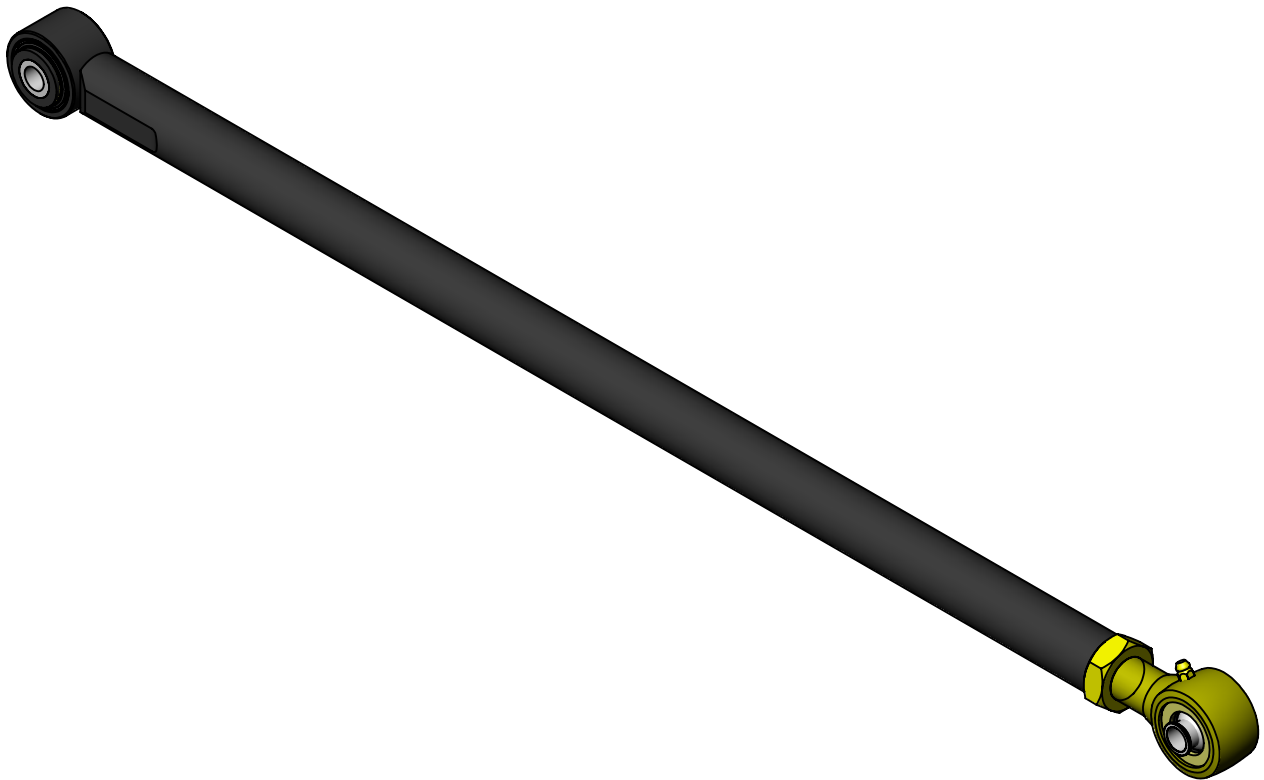

NOTES: This product may require general welding, fabrication and automotive mechanic skills. Welding should only be done by a competent welder. Clayton Off Road implies no guarantees or warranties and is not liable for improper installation. Some grinding and fitment may be required when installing this product. Every vehicle varies slightly and some fabrication may be required.

Refer to pictures below.

Step 1: Remove old track bar.

Step 2: Center frame on axle.

Step 3: Measure length from axle side mount to frame side mount.

Step 4: Adjust track bar to length and run jam nut up to track bar tube.

Step 5: Install new track bar with adjustment end on axle.

Step 6: Install track bar bolts and nuts.

Step 7: Torques both bolts to 90 ft-lb.

Step 8: Tighten jam nut using a 1-7/16" wrench.

Step 9: Make sure Johnny Joint at frame side is centered in bracket.

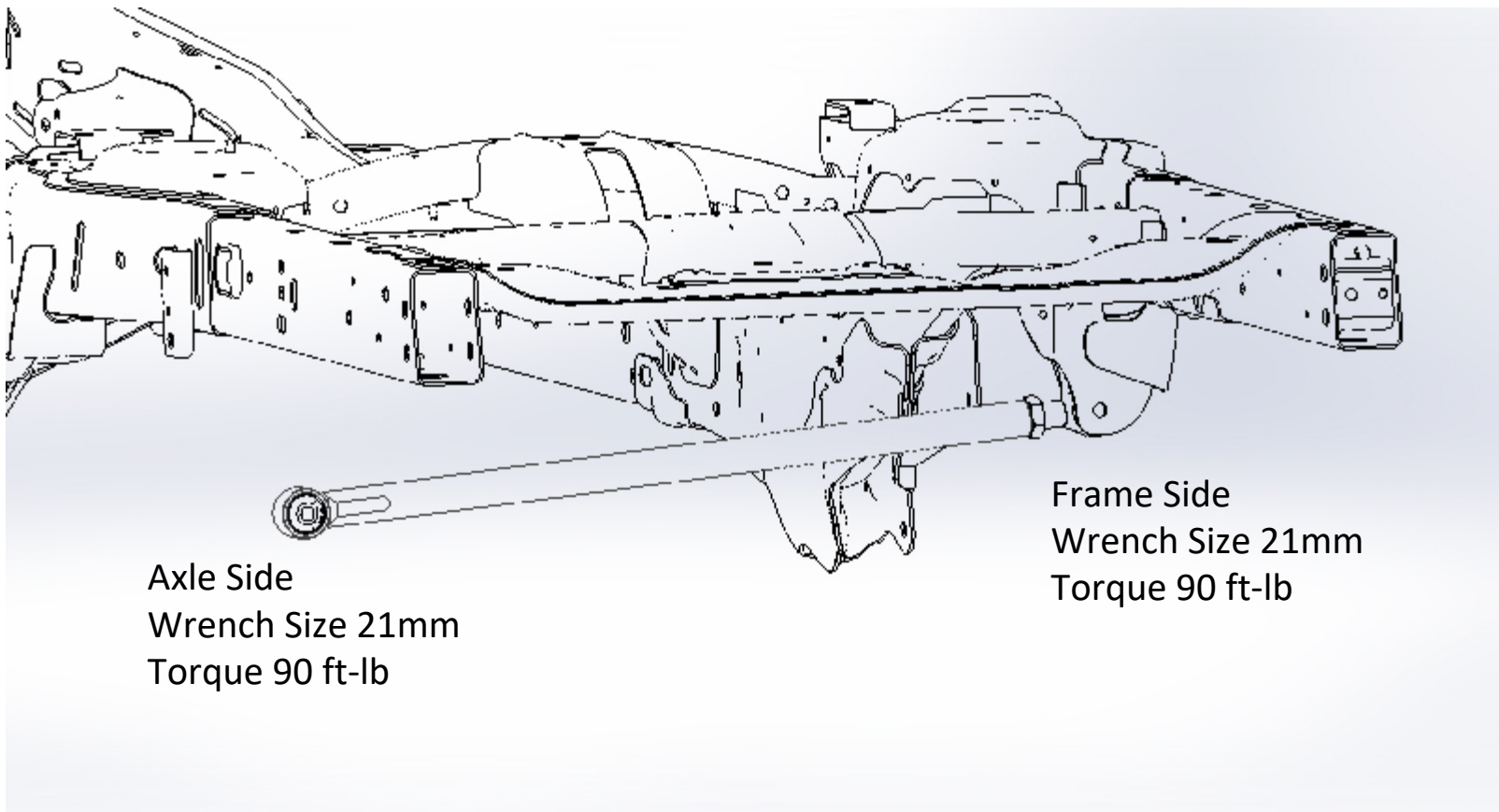

Refer to drawing below for minimum and maximum lengths.

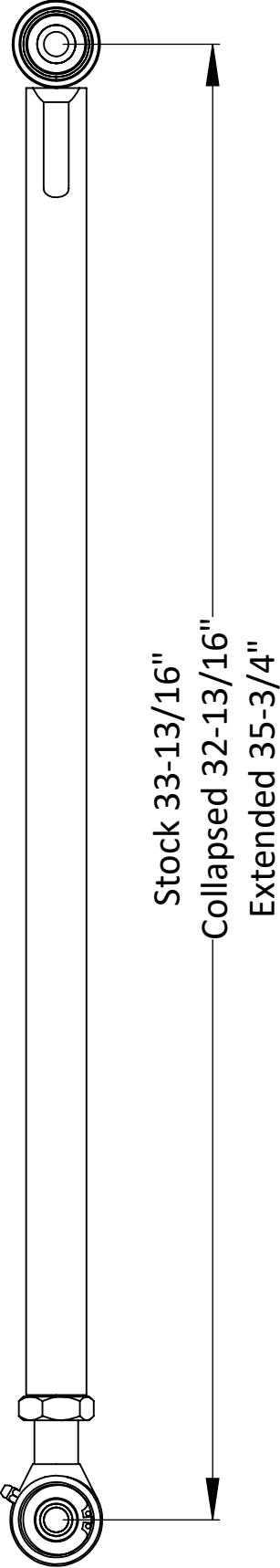

Clayton Off Road  
COR-1410200  
Jeep Gladiator Rear Bump Stops (2020 & Up, JT)

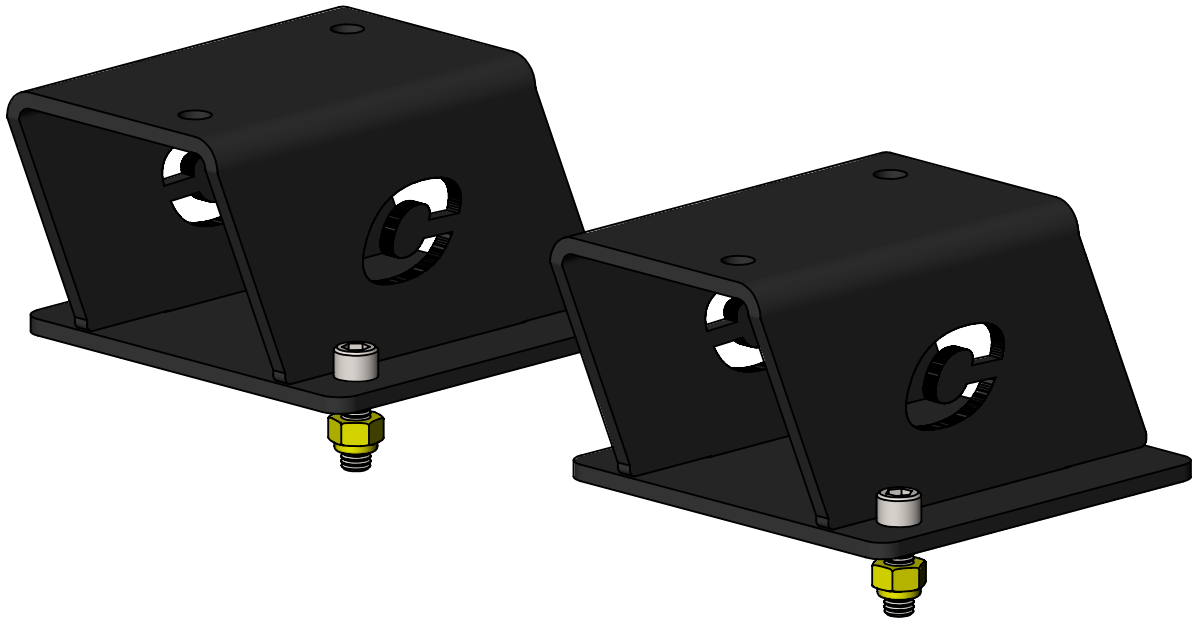

NOTES: This product may require general welding, fabrication and automotive mechanic skills. Welding should only be done by a competent welder. Clayton Off Road implies no guarantees or warranties and is not liable for improper installation. Some grinding and fitment may be required when installing this product. Every vehicle varies slightly and some fabrication may be required.

Refer to picture below.

Step 1: Locate bump stop on axle mount with holes lined up.

Step 2: Insert bolts from the top, thread nuts on.

Step 3: Torque bolts to 30 ft-lb.

Step 4: Repeat steps 1 to 3 on other side.

Optional bump stop extensions are available.

Part number COR-1410201

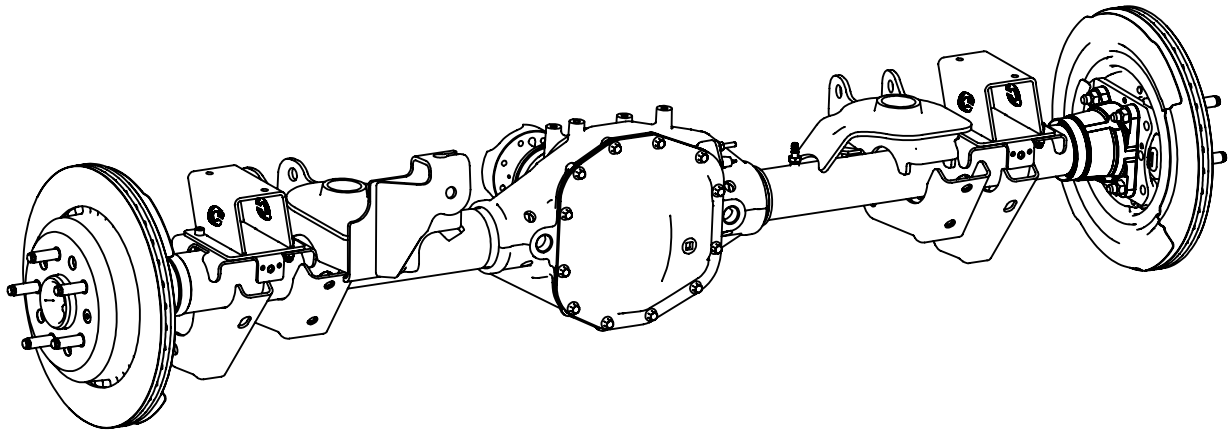

Clayton Off Road  
COR-5110110

Jeep Gladiator Adjustable Rear Sway Bar End Links (2020 & Up, JT)

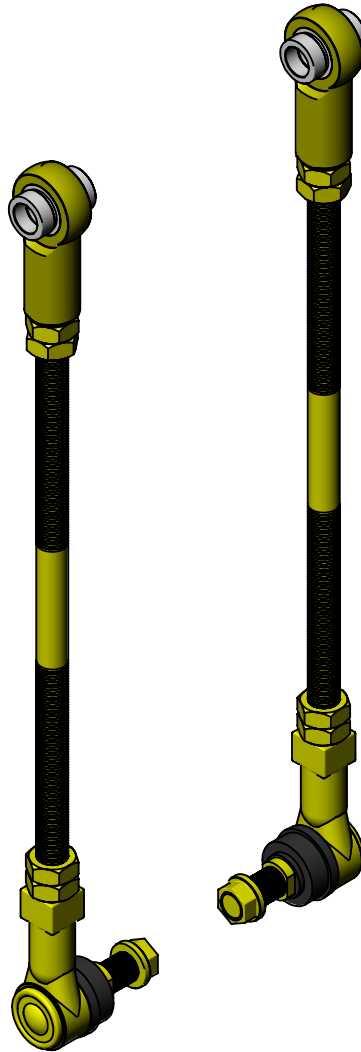

NOTES: This product may require general welding, fabrication and automotive mechanic skills. Welding should only be done by a competent welder. Clayton Off Road implies no guarantees or warranties and is not liable for improper installation. Some grinding and fitment may be required when installing this product. Every vehicle varies slightly and some fabrication may be required.

Refer to pictures below.

Step 1: Remove old sway bar end links.

Step 2: Make sure vehicle is at ride height.

Step 3: Set rear sway bar at about 9 degree upward angle.

Step 4: Measure the distance from the upper and lower mounting holes.

Step 5: Use the formula below to calculation rod length.

Step 6: Cut rod to length.

Step 7 Install two jam nuts on each end of rod.

Step 8: It maybe necessary to lock the 2 jam nuts against each other to thread rod end on.

Step 9: The rod ends without studs go on the top, use a aluminum spacer on each side of this rod end.

Step 10: Install sway bar links with the studs facing out.

Step 11: Make sure all rod ends are centered.

Step 12: Torque all nuts, bolts and jam nuts to 60 ft-lb.

Step 13: Cycle the suspension through its full travel, check for binding and adjust rod length if needed.

Step 14: Do not exceed maximum length

Step 15: Make sure to keep at least 3/4" of thread engagement with rod end.

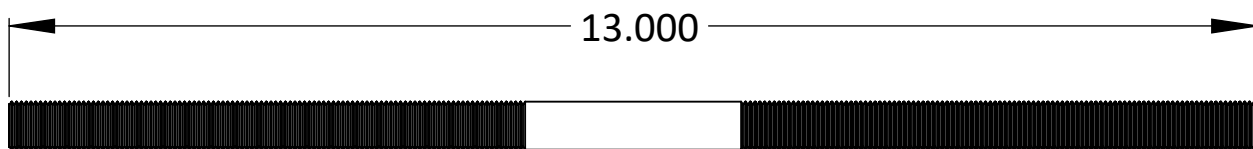

### Sway bar link rod length calculation

Take the center distance and subtract 2.625" from it, this is the rod length.

Subtract the rod length from 13.000" and divide it by 2.

This is the length to cut from each end of the rod.

Another option is to measure the stock sway bar link and add the amount of lift you are using to this dimension, then use the calculation above.

Refer to drawing below for minimum and maximum lengths.

