

**Clayton Off Road
COR-1709103
Jeep Wrangler Overland + Rear Upper Control Arms (2007 & Up, JK/JL)**

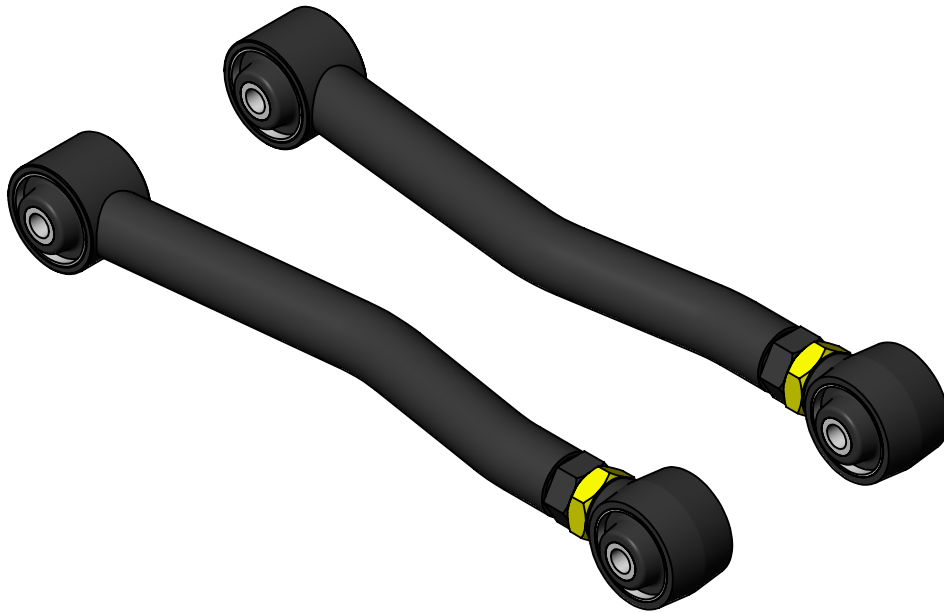

NOTES: This product may require general welding, fabrication and automotive mechanic skills. Welding should only be done by a competent welder. Clayton Off Road implies no guarantees or warranties and is not liable for improper installation. Some grinding and fitment may be required when installing this product. Every vehicle varies slightly and some fabrication may be required.

For more information please visit our website.

Refer to pictures below.

Step 1: Support axle from rotating, a floor or bottle jack works well.

Step 2: Remove old control arms.

Step 3: Set pinion angle desired pinion angle by adjusting the height of the jack.

Step 4: Install arms at frame side, arm should bow towards frame & adjuster at axle end.

Step 5: Adjust control arm to length so that bolts can easily be installed at axle end.

Step 6: Remove jack, and pinion angle.

Step 7: Torque all bolts to 95 ft-lb at axle end and 120 ft-lb at frame end.

Step 8: Tighten jam nut using a 1-7/16" wrench.

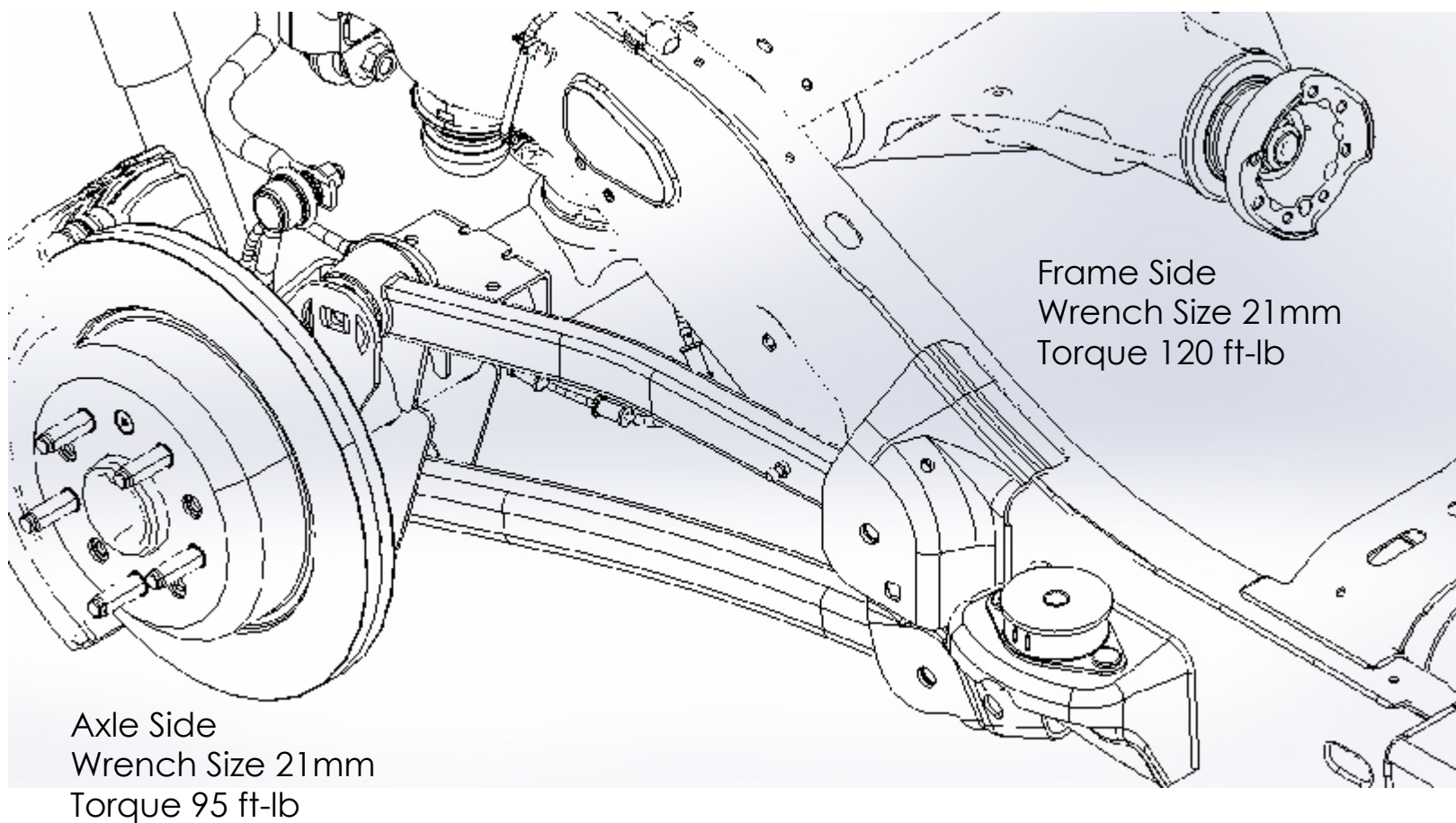

Refer to drawing below for minimum and maximum lengths.

