



**2005-2009 Mustang  
V6 "Shaker"  
CDC #0511-7001-01**

**Component Check List:**

<u>Quantity/Description</u>	<u>Part #</u>	<u>CDC</u>	<u>Installer</u>
<b>1 - Engine Cover Assembly</b>	<b>0511-6000-01</b>	<input type="checkbox"/>	<input type="checkbox"/>
• 1 - Engine Cover w/ Upper Air Tube	0511-2100-01	<input type="checkbox"/>	
• 1 - Aluminum Shaker Scoop	183020	<input type="checkbox"/>	
• 6 - M6-1.0 x 10mm Hex Head Bolts	183003	<input type="checkbox"/>	
• 4 - Fender Washers 1/4" x 1"	116051	<input type="checkbox"/>	
• 2 - Channel Washers	116052	<input type="checkbox"/>	
• 2 - M6-1.0 Nuts w/ Loose Washer	183034	<input type="checkbox"/>	
• 1 - Mustang Sill Plate	115055	<input type="checkbox"/>	
• 1 - Throttle Body Bracket	0511-3501-01	<input type="checkbox"/>	
• 1 - Shaker Badge	183012	<input type="checkbox"/>	
• 4 - Rivets	183011	<input type="checkbox"/>	
<b>1 - Upper Trim Ring</b>	<b>115051</b>	<input type="checkbox"/>	<input type="checkbox"/>
<b>1 - Lower Trim Ring</b>	<b>115050</b>	<input type="checkbox"/>	<input type="checkbox"/>
<b>1 - Lower Air Tube</b>	<b>115053</b>	<input type="checkbox"/>	<input type="checkbox"/>
<b>8 - Zip Ties</b>	<b>116053</b>	<input type="checkbox"/>	<input type="checkbox"/>
<b>4 - Rivets</b>	<b>183011</b>	<input type="checkbox"/>	<input type="checkbox"/>
<b>2 - 1/4"-20 x 3/4" Button head</b>	<b>116023</b>	<input type="checkbox"/>	<input type="checkbox"/>
<b>1 - Coilpack Relocator Bracket</b>	<b>0511-3502-01</b>	<input type="checkbox"/>	<input type="checkbox"/>
<b>1 - 3" x 7" Airtube w/ (2) Clamps</b>	<b>0511-2101-01</b>	<input type="checkbox"/>	<input type="checkbox"/>
<b>1 - Threaded 1/4"-20 insert</b>	<b>0511-3500-01</b>	<input type="checkbox"/>	<input type="checkbox"/>
<b>1 - 1/4"-20 x 3/8" Button head</b>	<b>30004</b>	<input type="checkbox"/>	<input type="checkbox"/>
<b>2 - 1/4"-20 Flange nuts</b>	<b>45014</b>	<input type="checkbox"/>	<input type="checkbox"/>
<b>4 - 3/8" Drain Tubes</b>	<b>183027</b>	<input type="checkbox"/>	<input type="checkbox"/>
<b>1 - Roll 1/4"x70" 3m Tape</b>	<b>950015</b>	<input type="checkbox"/>	<input type="checkbox"/>
<b>2 - Alcohol Packs</b>	<b>950006</b>	<input type="checkbox"/>	<input type="checkbox"/>
<b>1 - Adhesion Promoter Pack</b>	<b>950007</b>	<input type="checkbox"/>	<input type="checkbox"/>
<b>1 - Air Filter Housing Template</b>	<b>CD4II3BU/CD4II3AJ</b>	<input type="checkbox"/>	<input type="checkbox"/>
<b>1 - Hood Template</b>	<b>CD4II3BU</b>	<input type="checkbox"/>	<input type="checkbox"/>
<b>1 - Installation Guide</b>	<b>CD4II3BU</b>	<input type="checkbox"/>	<input type="checkbox"/>



## V6 Mustang “Shaker” System Installation Instructions

**Note:** Read installation instructions before starting and test fit component before painting. The Shaker Hood Trim Ring is molded UV Stable ABS Plastic and does not require painting. To ensure the quality of your vehicle and the product, have your Trim Ring painted by a professional automotive painting facility (if applicable). We recommend that paint-curing temperature not exceed 150°F.

### Tool List For Trim Ring:

- Template
- Masking Tape
- Center Punch
- 1/8” Pilot Drill Bit
- 1” Hole Saw
- Drill Motor
- Saw with metal blade (for cutting hood)
- Utility Knife or Hobby Knife (for cutting hood blanket)
- Razor Blade
- Eye Protection
- Rivet Gun
- 80 – 120 grit sand paper

### Tool List For Shaker Assembly & Install:

- |  |   |
|--|---|
| <input type="checkbox"/> 15mm Socket 3/8” Drive  | <input type="checkbox"/> Drill Motor                  |
| <input type="checkbox"/> 10mm Socket 1/4” Drive  | <input type="checkbox"/> 1/8” Pilot Drill             |
| <input type="checkbox"/> 8mm Socket 1/4” Drive   | <input type="checkbox"/> 2 3/4” Hole Saw              |
| <input type="checkbox"/> 7mm Socket 1/4” Drive   | <input type="checkbox"/> Rivet Gun                    |
| <input type="checkbox"/> 7/16” Socket 1/4” Drive | <input type="checkbox"/> Half Round File              |
| <input type="checkbox"/> 1/4” Drive 6” extension | <input type="checkbox"/> Thread locker                |
| <input type="checkbox"/> 1/4” Drive Ratchet      | <input type="checkbox"/> Utility Knife or Hobby Knife |
| <input type="checkbox"/> 3/8” Drive Ratchet      | <input type="checkbox"/> Eye Protection               |
| <input type="checkbox"/> 5/32” Allen Wrench      | <input type="checkbox"/> Drop Cloth                   |

**Cutting Shaker Opening in Hood:**

- A) Raise Hood and remove under hood blanket. Use a fork tool to remove pushpin fasteners. Set hood blanket aside. Close hood and mask off entire area where Shaker opening will be cut out to help prevent paint damage during the cutting process. Place tape along edges of hood as well for measurement marks (refer to hood drawing below).



- B) Measure and mark centerline on the hood. From the rear corners of the hood, along the hood/fender gap, measure toward the front of the car and place a mark at 7" and 38" along both driver and passenger side of the hood. Next, at these marks, measure from the outside of the hood towards the center to mark the centerline. **Hint:** From the 7" mark, it is *approximately* 29-5/8" to the center. From the 38" mark, it is *approximately* 28-9/16" to the center. These measurements are intended as reference only. **Note: Double Check Your Measurements, It is very important that the centerline of hood is measured accurately.** Now that you are confident of your measurements, use a straight edge to draw the centerline on the hood.

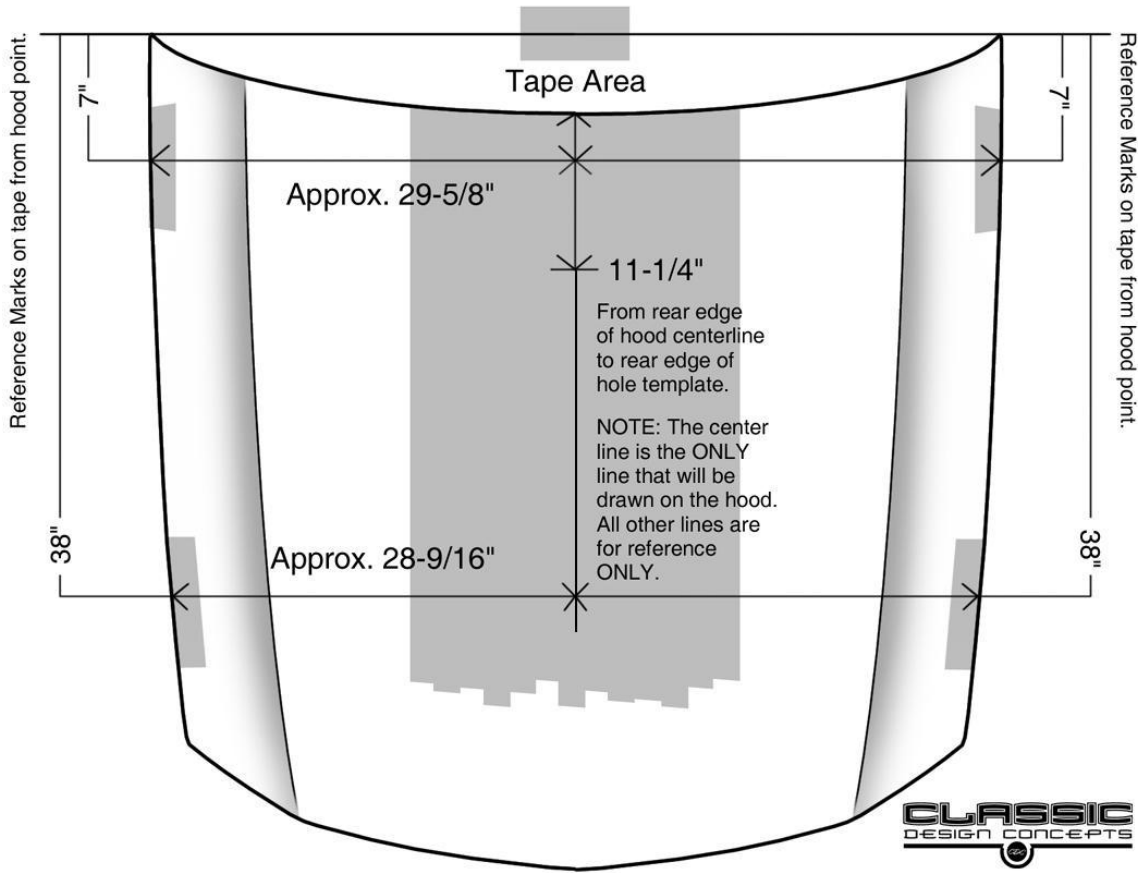

## CD4II3BU

- C) Measure and mark 11-1/4" from rear of the hood on the centerline. This will line up with the rear line on the shaker cutout template.

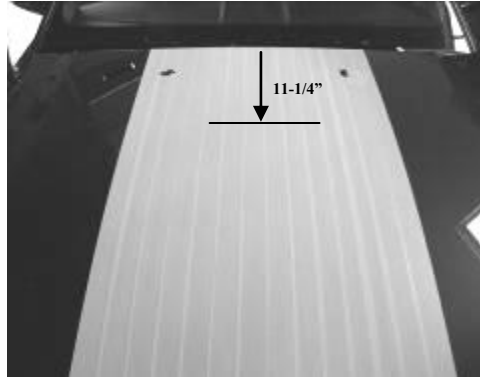

### Note:

It is very important that the centerline of hood is measured accurately. Make sure to line up centerline of template to centerline drawn on hood. The best way to achieve this is to cut a hole along the centerline at the rear of the shaker hole outline on the template, so the marks you've drawn on the tape show through. (See Below)

- D) Align template on hood with 11-1/4" mark at rear of template, and align centerlines of template with the ones drawn on the hood. Tape template securely to top of hood.

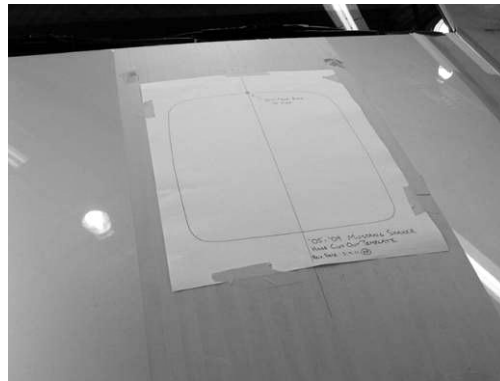
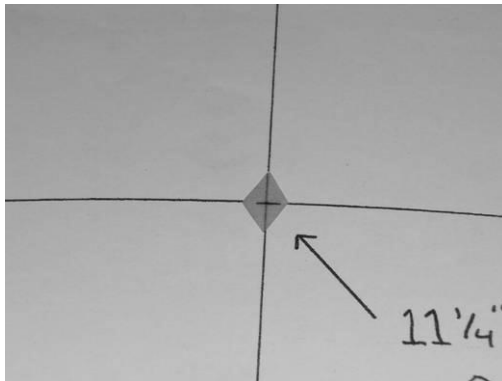

- E) With a sharp razor blade or x-acto knife cut through template, through the tape, and into the paint of your hood along the cut-out line. Cutting/scoring the paint on the hood will reduce the chance of paint flake during the cutting process.



- F) Remove template from hood and discard. Peel tape from center of Shaker opening, leaving an outline of Shaker opening. **CAUTION:** Add a second layer of tape around opening to reduce the risk of shavings scratching the hood.

## CD4II3BU

**Note:** During the drilling and cutting process, elevate the hood far enough to ensure no damage will occur to engine components; a 4"x4" block of wood will suffice. Place a blanket over engine to catch metal shavings.



- G) Center punch and drill a starter hole in the Shaker opening large enough to accommodate your saw's blade.
- H) Cut Shaker opening following the outline. Be patient and pay attention to your blade; if it appears to be getting clogged, stop cutting and replace blade. **Hint: Stop cutting half way around opening and place masking tape over cut line for support, or place paint stirring sticks under the corners. This will support the center cut-out panel and prevent it from pinching the saw blade.**
- I) Use air compressor or similar to blow off metal shavings from vehicle. Raise hood and carefully remove blanket.

## 2. Installing Shaker:

- A) Remove Air Box by loosening hose clamp with 8mm socket and remove the 10mm bolt attaching the filter housing to the body. Unplug Mass Airflow Sensor at this time. Remove entire filter housing from vehicle.

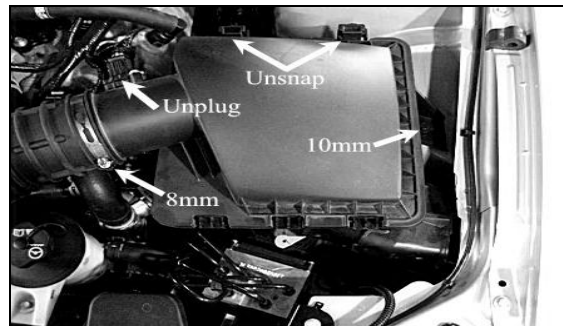

- B) Remove the 7mm coil pack bolts (4) and unclip the two wire looms to remove coil pack from mounting bracket.
- C) Remove the 8mm Bolts (2) from the top of the coil pack bracket.

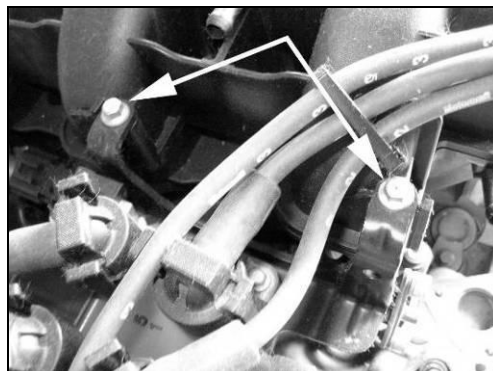

## CD4II3BU

- D) Temporarily remove the EVAC hose from the valve cover and the intake tube.
- E) Remove the 10mm and 15mm bolts that secure the coil pack bracket to the side of the engine.

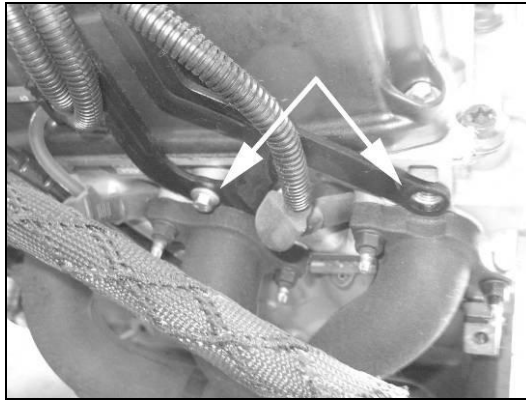

- F) Trim the factory bracket with a cut-off wheel or hack saw. Follow lower horizontal line of the “FoMoCo” logo. Paint the cut area to prevent rust. (See figure below)



- G) Attach Coil Pack Relocator bracket (Part# 0511-3502-01) with the supplied stainless steel 1/4”-20X3/4” button head screws and flange nuts (using a 5/32” Allen Wrench and a 7/16” Socket.)
- H) Reinstall bracket to the vehicle. Thread all bolts by hand before tightening. (Two 8mm bolts on top, 15mm bolt on the bottom rear, and the 10mm bolt on the bottom front.)
- I) Reinstall coil pack using four 7mm bolts.  
**Note: Make sure you secure the ground wire when reinstalling the coil pack.**
- J) Reinstall EVAC tube.
- K) Tuck the passenger side plug wires behind the upper intake manifold.

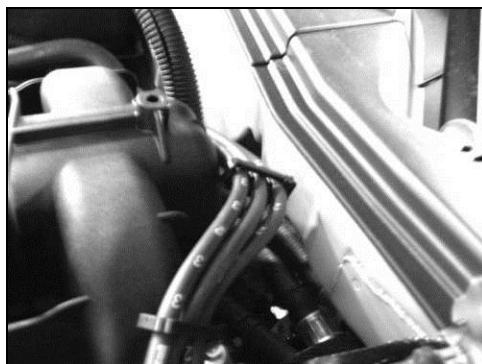

## CD4II3BU

- L) Install threaded insert (part# 0511-3500-01) into the upper intake.

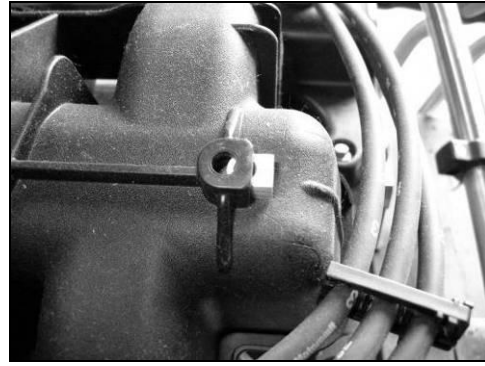
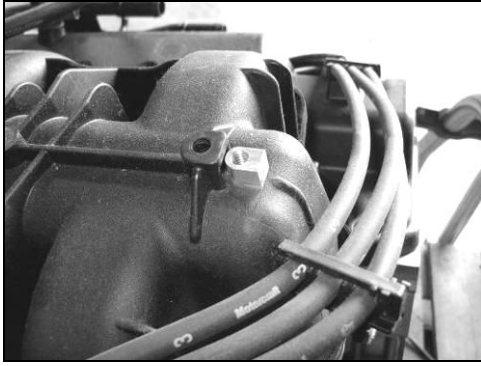

- M) Remove the top two 8mm throttle body bolts and the oil fill cap.

**Note:** Some cars may be equipped with an oil filler neck extension. If your vehicle is equipped with this, twist off at base, do not reinstall.

- N) Rotate Passenger side EVAC hose as shown.

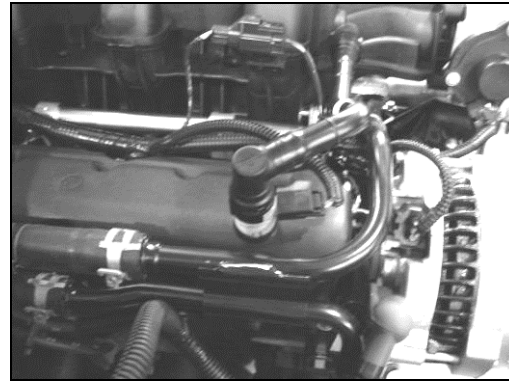
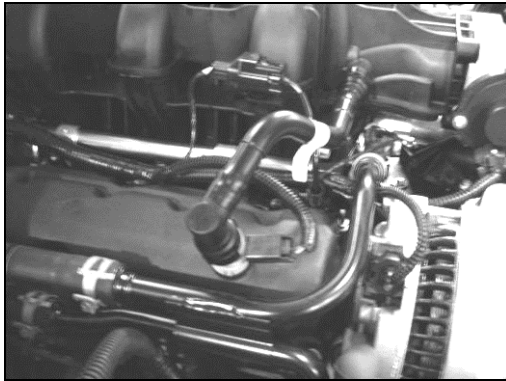

- O) Bend tabs for the engine ground and wiring harness on the firewall down.

- P) Install air box coupler (Part# 0511-3501-01) to engine cover.

**Note:** Clamp on the inside for a cleaner look. Do not over tighten.

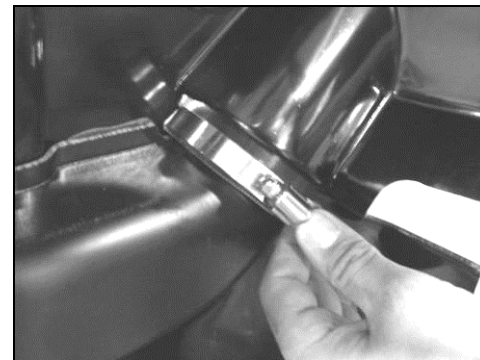
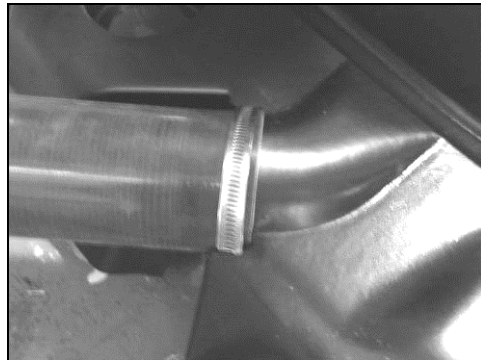

- Q) Attach the Drain tubes (4 – part# 183027) to the engine cover and secure them with the supplied Zip Ties (Part# 116053).

- R) Using the Air Box Template, mark and cut the hole in the lower air box.

**Caution:** It is very important that the hole in the air box is precisely cut to 3". We recommend using a 2 3/4" hole saw, then filing by hand to achieve proper diameter.

- S) Snap Lower Air Tube (part # 115053) into air box.

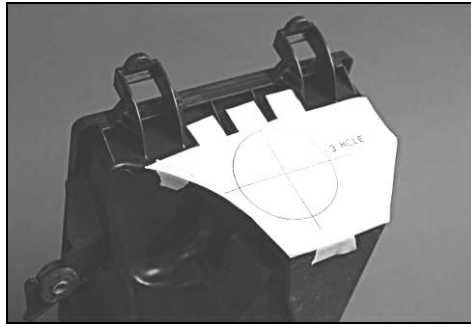

- T) Re-install Factory Air Filter into factory air box.
- U) Reinstall air filter housing top onto air box and snap locking tabs into place.
- V) Reinstall air filter housing into vehicle.
- W) Place Shaker engine cover into place on engine. Route drain tubes away from moving parts and hot surfaces. (4 extra zip ties are provided to secure drain tubes). Align the Shaker bracket with the throttle body bolt holes and reinstall the two 8mm throttle body bolts. Secure rear of engine cover with the supplied 1/4"-20X3/8" button head screw behind the aluminum scoop.

**Note: Bracket is slotted for adjustment.**

- X) Route Mass Air Flow connector through the engine cover and reconnect to sensor.
- Y) Slide Coupler over Lower Air Tube (part #115053), and tighten clamps. (do not over tighten)

### **Installing Hood Trim Ring**

- A) Remove tape from hood. Clean area of hood around the cut opening with Isopropyl (rubbing) Alcohol where Upper Trim Ring will be placed. **It is imperative that any wax be removed from the vehicle at the tape contact area for proper adhesion of Trim Ring.**
- B) Apply 3m Acrylic Bonding tape (part #950015) to bottom side of Upper Trim Ring. Sand area with 80-120 grit sand paper, clean with supplied Alcohol pack and allow time to dry, apply supplied Adhesion Promoter and allow time to dry, apply 3m tape. Press on tape with fingertips to set tape.
- C) Peel 3"-4" of the red backing from the Upper Trim Ring (part # 115051) and place in hood opening. Align trim ring with scoop so that spacing is even around perimeter of scoop. When proper placement is achieved, finish peeling the red backing from acrylic bonding tape and press on trim ring to set tape to hood. Make adjustments to Shaker engine cover if needed.
- D) Raise and prop hood.
- E) Temporarily install hood blanket to bottom of hood using factory fasteners and trace inside of Upper Trim Ring onto the hood blanket. Remove hood blanket and set on bench. (A white grease pen works best.)



- F) With the hood blanket on the bench, line up the Lower Trim Ring (part # 115050) with the line traced from the upper. Now trace the outside of the Lower Trim Ring onto the hood blanket. **Note:** Trim Ring will follow contour of the hood blanket when properly positioned, the hump is toward the rear. Remove Lower Trim Ring and measure 1/2" from the outer line toward the center of the hood blanket and mark one more line, this is the line you will cut using a sharp blade. Cut out blanket.



CD4II3BU

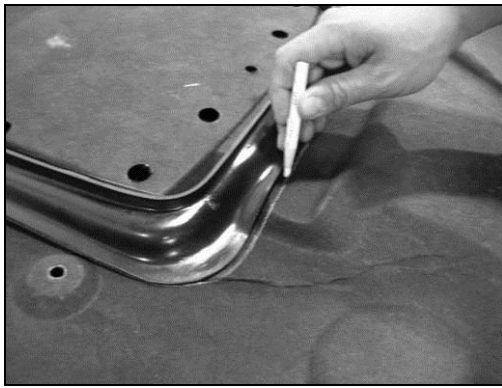

- G) Reinstall hood blanket with factory retainers in their proper locations.
- H) Install the Lower Trim Ring onto the Upper Ring flange, squeeze until trim rings snap together. The Lower Trim Ring will hold the hood blanket in place around the opening.
- I) There are two 3/32" holes that are predrilled in the front and rear of the Upper and Lower Trim Rings (4 total). Use #183011 rivets to secure the Upper and Lower Trim Rings together.

**Congratulations your installation is complete!**



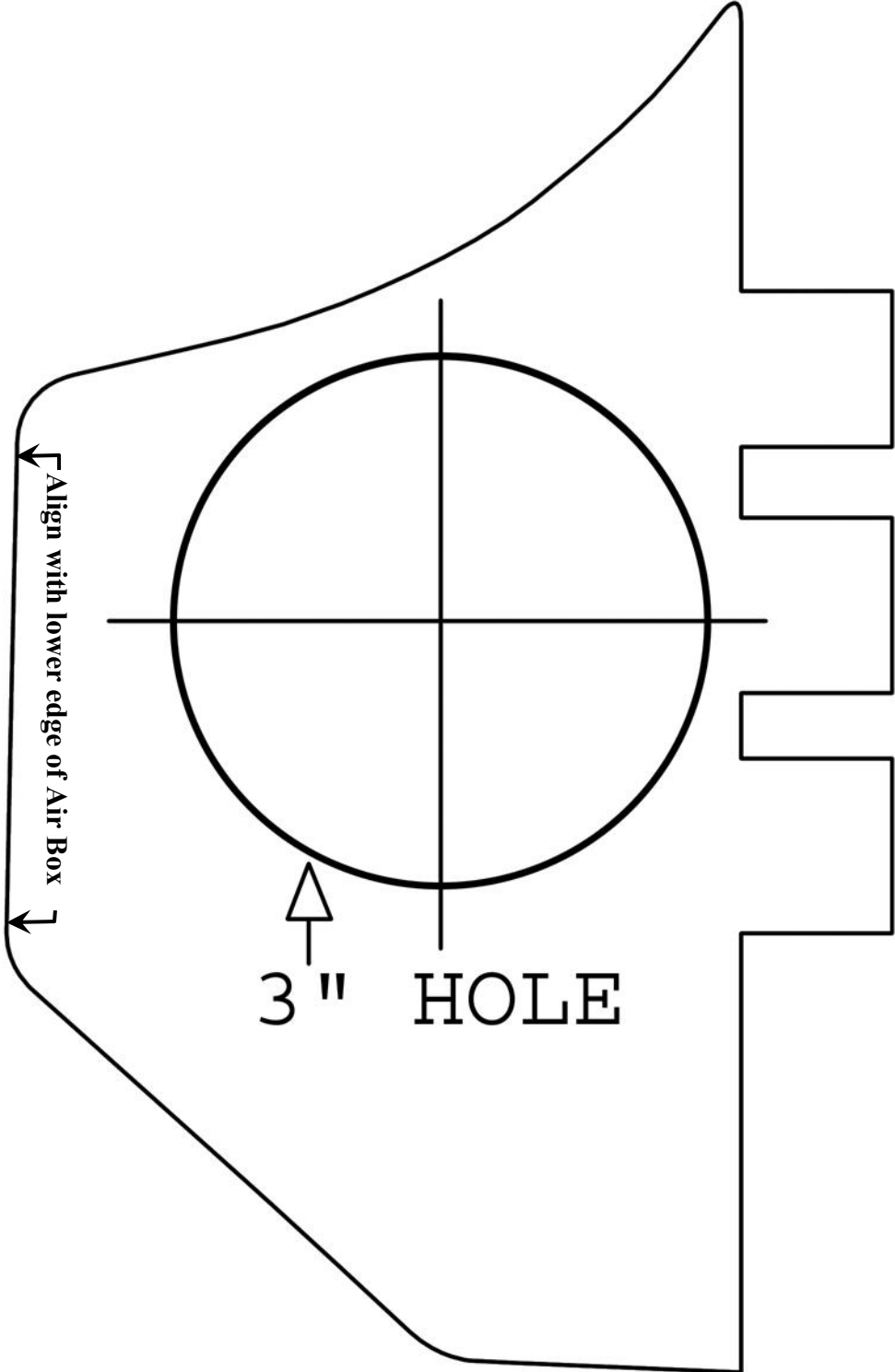

05-07 Mustang  
Shaker  
Air Box Cut Out  
6-8-05  
CD4113AJ