

# Instructions: StormPro™ Trailerable Pontoon Boat Cover



## CAUTION

If your boat is new, use of this product is not recommended within the first four weeks of ownership of the boat. Some compounds used in new boats can release gases that will cause the dyes in boat covers to transfer to the boat, potentially staining the boat or its components. Boat covers can be used safely after this introductory period.

## CAUTION

This large cover will be easier to apply with two people.

## CAUTION

Be sure to secure all straps, ropes and elastic cords before transporting your boat. Failure to do so could cause the cover to come loose and will invalidate your warranty.

## Additional Parts Included

- Two elastic hooked cords
- Rope

## Tools Required

Scissors and matches or a lighter

## Installation

1. Cover any sharp points or corners with a piece of cloth to avoid stressing or tearing your boat cover when it is stretched across your boat.
2. Drape the boat cover over your boat with the end marked "FRONT" at the bow.
3. Pull your cover down below the rub rail around the entire boat.
4. Attach the fitting straps (A) dangling from the bottom sides of the cover to the trailer frame by taking each strap down under the trailer frame rail then back up to the corresponding insert buckle at the edge of the cover. Snap the male end of the strap (A) into the buckle. After attaching all the remaining straps adjust their length to secure your cover in place.
5. To secure the transom flap, first locate the adjustable cover side panels (B) and wrap them towards the center of the boat. Secure them in place by hooking the hem elastic cord hooks (C) together. Cinch the D-rings on the adjustable side panels together using the two provided hooked elastic cords.

Fold the transom flap (D) over the side panels (B) and adjust the transom flap (D) to determine which row of D-rings on the transom flap allows you to best cover the stern of your boat. When using the top row of D-rings, tuck excess transom flap under. Secure by tying the provided rope to an end D-ring then weaving the rope from the D-ring to the trailer frame, and then to the next D-ring,

until all the transom flap D-rings are secured. Tie off the rope to the trailer frame.

6. Cut excess rope and carefully singe the ends of the rope with a match or lighter to prevent fraying.

7. Adjust and tighten as necessary for your particular boat. Before driving always check that all straps, ropes and hooks are tightly secured. We recommend that after the first mile of driving that you recheck your cover.

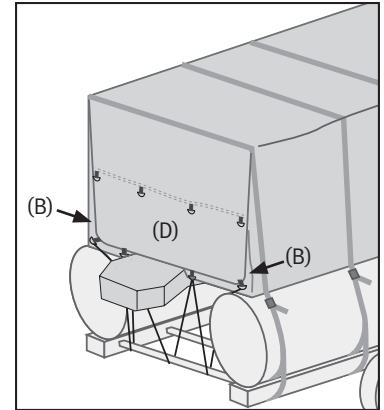

## Care and Cleaning

Spot clean with water, a mild soap and a sponge. Don't use abrasive cleaners or brushes.

## Storage

A handy storage bag is provided to store your boat cover in. If you wish to store your cover for an extended period, be sure that it is completely dry before storage.

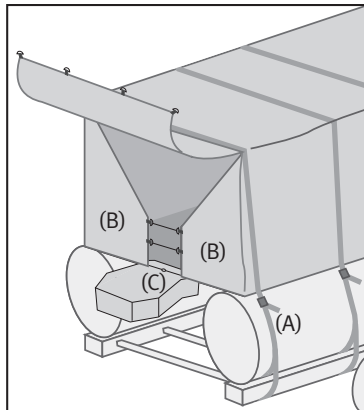

CLASSIC ACCESSORIES, INC.