

Operator's Manual



CP871 CP873

Tire Buffer



⚠ WARNING

To reduce risk of injury, everyone using, installing, repairing, maintaining, changing accessories on, or working near this tool must read and understand these instructions before performing any such task.

INSTRUCTION MANUAL

Machine Type:

Power tool equipped with slip chuck and 3/8 in.-24 adapter or drill chuck for use with various rasps for tire repair - No other use is permitted.

Air Supply Requirements

1. Supply tool with 90 psig (6.3 bar) of clean, dry air. Higher pressure drastically reduces tool life.
2. Connect tool to air line using pipe, hose and fitting sizes shown in the diagram below.

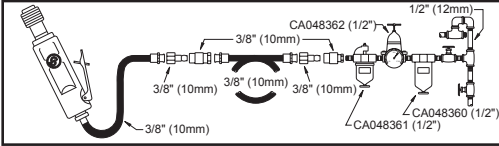

Lubrication

1. Use an air line lubricator with SAE #10 oil, adjusted to two drops per minute. If an air line lubricator cannot be used, add air motor oil to the inlet once a day.
2. Make sure adequate lubrication is provided for internal gears for long life.

Maintenance

1. Disassemble and inspect tool every three months if the tool is used every day. Replace damaged or worn parts.
2. High wear parts are underlined in the parts list.

Technical Data

Free speed:

CP871 : 22000 RPM

CP873 : 2800 RPM

Air pressure 90 psi (6.3 bar)

Original Instructions

Copyright 2011, Chicago Pneumatic Tool Co. LLC

All rights reserved. Any unauthorized use or copying of the contents or part thereof is prohibited. This applies in particular to trademarks, model denominations, part numbers and drawings. Use only authorized parts. Any damage or malfunction caused by the use of unauthorized parts is not covered by Warranty or Product Liability.

Noise & Vibration Declaration

Sound pressure level

CP871 : 88 dB(A)

CP873 : 87 dB(A)

uncertainty 3 dB(A), in accordance with EN ISO 15744. For sound power, add 11 dB(A).

Vibration value:

CP871 : $a=3 \text{ m/s}^2$. uncertainty $k=1.8 \text{ m/s}^2$; re. ISO 28927 -5,

CP873 : $a=4.8 \text{ m/s}^2$. uncertainty $k=3.3 \text{ m/s}^2$; re. ISO 28927-1.

Declaration of noise and vibration emission

All values are current as of the date of this publication.

These declared values were obtained by laboratory type testing in accordance with the stated standards and are suitable for comparison with the declared values of other tools tested in accordance with the same standards. These declared values are not adequate for use in risk assessments and values measured in individual work places may be higher. The actual exposure values and risk of harm experienced by an individual user are unique and depend upon the way the user works, the workpiece and the workstation design, as well upon the exposure time and the physical condition of the user. We, Chicago Pneumatic, cannot be held liable for the consequences of using the declared values, instead of values reflecting the actual exposure, in an individual risk assessment in a work place situation over which we have no control.

This tool may cause hand-arm vibration syndrome if its use is not adequately managed.

We recommend a programme of health surveillance to detect early symptoms which may relate to noise or vibration exposure, so that management procedures can be modified to help prevent future impairment.

SAFETY INSTRUCTIONS

• DO NOT DISCARD - GIVE TO USER

- Our goal is to produce tools that help you work safely and efficiently. The most important safety device for this or any tool is YOU. Your care and good judgement are the best protection against injury. All possible hazards cannot be covered here, but we have tried to highlight some of the important ones.
- Only qualified and trained operators should install, adjust or use this power tool.
- This tool and its accessories must not be modified in any way.
- Do not use this tool if it has been damaged.
- If the rated speed, operating pressure or hazard warning signs on the tool cease to be legible or become detached, replace without delay.

▲ Air supply and connection hazards

- Air under pressure can cause severe injury.
- Always shut off air supply, drain hose of air pressure and disconnect tool from air supply when not in use, before changing accessories or when making repairs.
- Never direct air at yourself or anyone else.
- Whipping hoses can cause severe injury. Always check for damaged or loose hoses and fittings.
- Do not use quick disconnect couplings at tool. See instructions for correct set up.
- Whenever universal twist couplings are used, lock pins must be installed.
- Do not exceed maximum air pressure of 6.3 bar / 90 psig, or as stated on tool nameplate.

▲ Entanglement hazards

- Keep away from rotating drive spindle and abrasive. Rotation may continue for several seconds after the throttle has been released. Do not lay the tool down until rotation has stopped.
- Choking, scalping and / or lacerations can occur if loose clothing, gloves, jewellery, neck ware and hair are not kept away from tool and accessories.

▲ Projectile hazards

- Failure of the accessory or abrasive, or of the workpiece, can generate high-velocity projectiles. Even small projectiles can injure eyes and cause blindness.
- Always wear impact-resistant eye and face protection when involved with or near the operation, repair or maintenance of the tool or changing accessories on the tool.
- Be sure all others in the area are wearing impact-resistant eye and face protection
- Use barriers to protect others from wheel fragments and grinding sparks.
- Daily measure the air tool speed with a tachometer to make sure that it is not greater than the RPM marked on the grinding accessory.
- Ensure that the abrasive is securely clamped to the die grinder using the tools provided.

- Ensure that the workpiece is securely fixed.

▲ Accessory hazards

- Always shut off air supply, relieve hose of air pressure and disconnect tool from air supply when changing accessories.
- Use only recommended sizes and types of accessories and consumables.
- Do not use mounted wheels which are chipped or cracked, or may have been dropped.
- Never mount a grinding wheel, cut-off wheel or router cutter on a die grinder. A grinding wheel that bursts can cause very serious injury or death.
- Never use an abrasive with a permitted speed lower than the air grinder speed.
- Correct mounting is necessary to prevent injury from broken mounted wheels.
- Ensure the shaft diameter of the accessory is correct for the size of collet.
- Maximise the gripping length of the accessory: it must not be less than 10mm (0.39 inch). Increased overhang of a mounted wheel reduces its permitted speed – refer to manufacturer's recommendations and ANSI B7.1.
- Before grinding, test mounted wheel by briefly running tool at full throttle. Be sure to use a barrier (such as under a heavy work table) to stop any possible broken wheel parts. Stop immediately if vibration is excessive.

▲ Operating hazards

- Operators and maintenance personnel must be physically able to handle the bulk, weight and power of the tool.
- Hold the tool correctly: be ready to counteract normal or sudden movements – have both hands available.
- You can be cut or burned if you come into contact with the accessory, grinding sparks or the work surface. Avoid contact and wear protective equipment such as gloves, apron and helmet.
- Do not use if vibration becomes excessive: check the accessory for damage or incorrect mounting.
- Ensure that sparks do not cause a hazard to people or materials.
- There is a risk of electrostatic discharge if used on plastic and other non-conductive materials.

▲ Repetitive motion hazards

- When using a power tool to perform work-related activities, the operator might experience discomfort in the hands, arms, shoulders, neck, or other parts of the body.
- Adopt a comfortable posture whilst maintaining secure footing and avoiding awkward or off-balance postures. Changing posture during extended tasks can help avoid discomfort and fatigue.
- Do not ignore symptoms such as persistent or recurring discomfort, pain, throbbing, aching, tingling, numbness, burning sensation, or stiffness. Stop using the tool, tell your employer and consult a physician.

▲ Noise and vibration hazards

- High sound levels can cause permanent hearing loss and other problems such as tinnitus. Use hearing protection as recommended by your employer or occupational health and safety regulations.
- Exposure to vibration can cause disabling damage to the nerves and blood supply of the hands and arms. Wear warm clothing and keep your hands warm and dry. If numbness, tingling, pain or whitening of the skin occurs, stop using tool, tell your employer and consult a physician.
- Hold the tool in a light but safe grip because the risk from vibration is generally greater when the grip force is higher. Where possible support

the weight of the tool with a balancer.

- To prevent unnecessary increases in noise and vibration levels:
 - Operate and maintain the tool, and select, maintain and replace the accessories and consumables, in accordance with this instruction manual;
 - Use damping materials to prevent workpieces from "ringing".

⚠ Workplace hazards

- Slip/Trip/Fall is a major cause of serious injury or death. Be aware of excess hose left on the walking or work surface.
- Avoid inhaling dust or fumes or handling debris from the work process which can cause ill health (for example, cancer, birth defects, asthma and/or dermatitis). Use dust extraction and wear respiratory protective equipment when working with materials which produce airborne particles.
- Some dust created by power sanding, sawing, grinding, drilling and other construction activities contains chemicals known to the State of

California to cause cancer and birth defects or other reproductive harm. Some examples of these chemicals are:

- Lead from lead based paints
- Crystalline silica bricks and cement and other masonry products
- Arsenic and chromium from chemically-treated rubber
- Your risk from these exposures varies, depending on how often you do this type of work.
- To reduce your exposure to these chemicals: work in a well ventilated area, and work with approved safety equipment, such as dust masks that are specially designed to filter out microscopic particles.
- Proceed with care in unfamiliar surroundings. Hidden hazards may exist, such as electricity or other utility lines.
- Potentially explosive atmospheres can be caused by dust and fumes resulting from sanding or grinding. Always use dust extraction or suppression systems which are suitable for the material being processed.
- This tool is not intended for use in potentially explosive atmospheres and is not insulated from coming into contact with electric power.

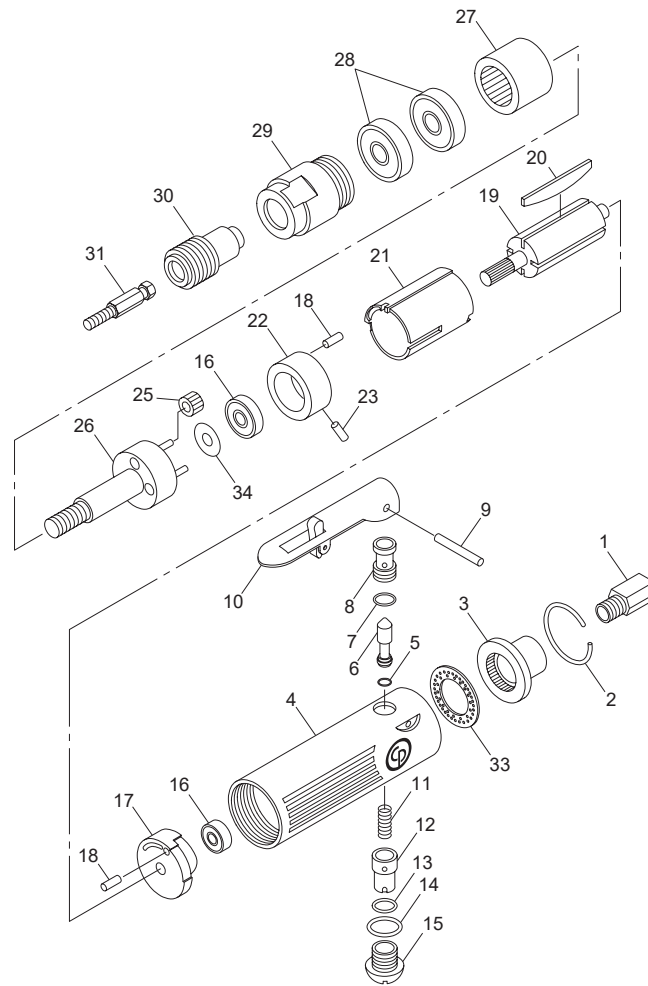

Index No.	Parts No.	Description	Qty
1	CA144870	Bushing-Air Inlet (Model A)	1
	CA157739	Bushing-Air Inlet (Model B)	1
2	CA144871	Ring-Retaining (Model A Only)	1
3	<u>CA144872</u>	Deflector-Exhaust (Model A)	1
	<u>CA157734</u>	Deflector-Exhaust (Model B)	1
4	CA144914	Housing-Motor (Model A)	1
	CA157737	Housing-Motor (Model B)	1
5	CA144874	O-Ring	1
6	CA144875	Valve-Throttle	1
7	<u>CA144876</u>	O-Ring	1
8	CA144877	Bushing-Throttle Valve	1
9	CA144878	Pin-Roll	1
10	CA144879	Lever-Throttle	1
11	<u>CA144880</u>	Spring-Throttle Valve	1
12	CA144881	Regulator-Air	1
13	CA144882	O-Ring	1
14	CA144883	O-Ring	1
15	CA144884	Plug-Throttle Valve	1
16	<u>CA144885</u>	Bearing-Ball	2
17	<u>CA144886</u>	Plate-Rear End (Includes: Index No. 18)	1
18	CA144887	Pin-Roll	2
19	CA144916	Rotor	1
20	<u>CA144889</u>	Blade Set-Rotor (4)	1
21	CA144891	Liner	1

Index No.	Parts No.	Description	Qty
22	CA144917	Plate-Front End (Includes: Index Nos. 18 & 23)	1
23	CA144893	Pin-Roll	1
25	CA144919	Gear-Idler (Incl. Bushing)	3
26	CA144920	Spindle	1
27	CA144921	Gear-Internal	1
28	CA145309	Bearing-Ball	2
29	CA144922	Nut-Clamp	1
30	CA144923	Slip-Chuck	1
31	CA144924	Adaptor	1
	8940158533	3/8"-24 Adaptor W/2 Washers (Not Shown)	1
	8940162907	Adaptor Kit (Incl: CA144924 & 8940158533)	
33	CA157735	Silencer (Model B)	1
34	8940158831	Washer	1
	CA144918	Motor Assy. (Includes: Index Nos. 16, 17, 19, 20, 21, & 22) (Model A)	1
	CA127175	Rear Exhaust Accessory Kit (Model A)	1

	8940169059	Operator's Manual
	CA144813	Warning Label
	6159948750	Safety Instructions

Recommended Accessories

CA146632	Overhose exhaust 18"	8940175873	Tire Buffing Wheel 3/8" HEXA
CA047270	Whips hose 3/8X2 ft		



(4) declare that the product(s): **Tire Buffer**

(5) Machine type(s) :

CP871
CP873

Serial No:
From 00001 to 99999

(6) Origin of the product : Taiwan

(7) is in conformity with the requirements of the council Directives on the approximation of the laws of the Member States relating :

(8) to "**Machinery**" 2006/42/EC (17/05/2006)

(11) applicable harmonised standard(s) : ISO 11148-3: 2010 (CP871), ISO11148-9:2011 (CP873)

(12) NAME and POSITION of issuer :

Bruno BLANCHET
(General Manager)

(13) Place & Date : Saint-Herblain, 15/10/2012

