



**Chicago
Pneumatic**

Operator's Manual

CP85030 - 30 tons

CP85050 - 50 tons

CP85080 - 80 tons

CP85100 - 100 tons

Air Hydraulic Jack



WARNING

To reduce risk of injury, everyone using, installing, repairing, maintaining, changing accessories on, or working near this tool must read and understand these instructions, as well as separately provided safety instructions part number 8940170883, before performing any such task.

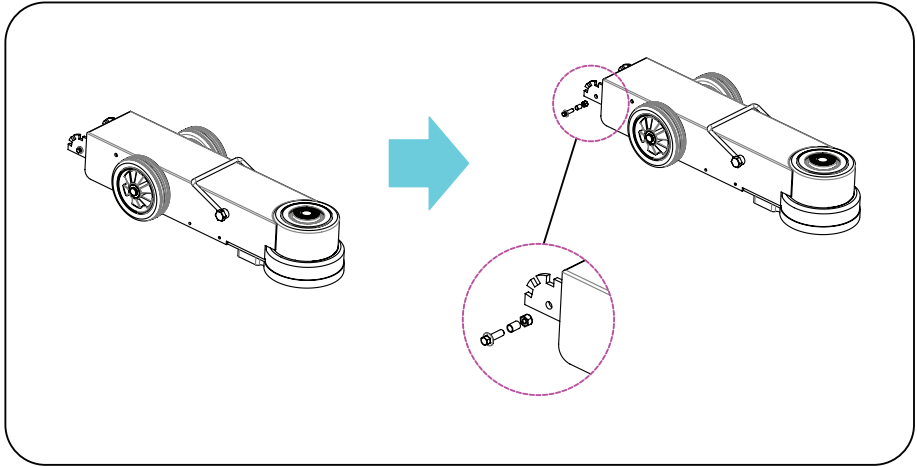
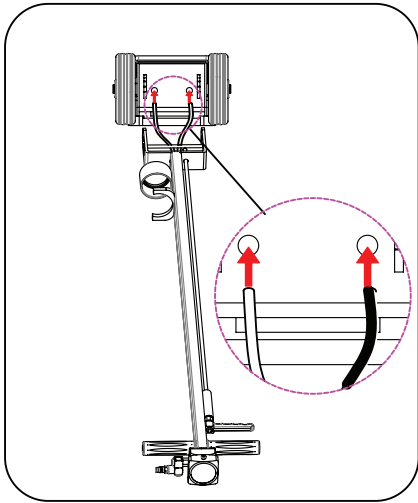
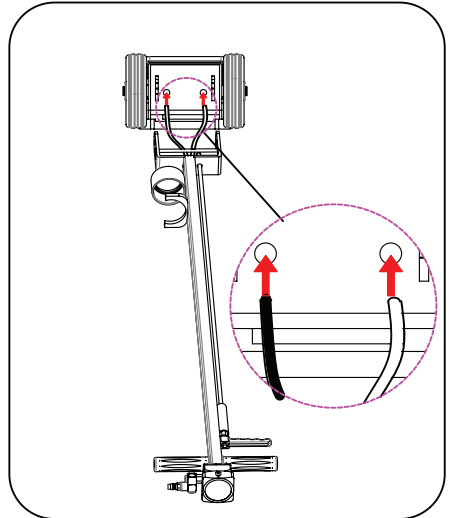

Fig. 01



50T / 80T / 100T



30T

Fig. 02

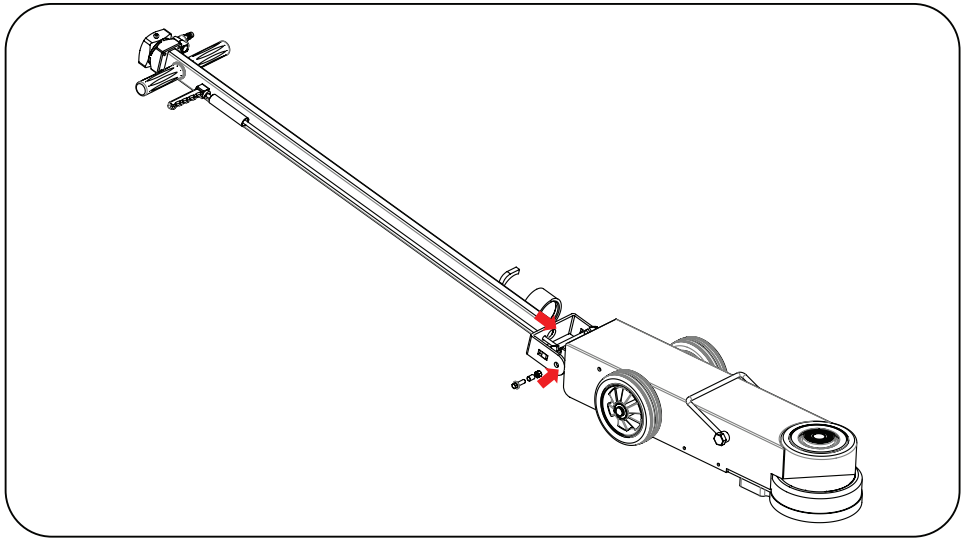

Fig. 03

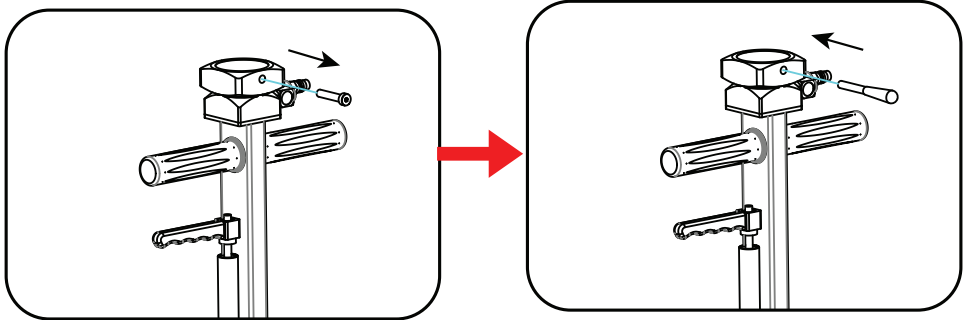

Fig. 04

OIL TYPE : ISO VG#15

Working theory(lifting up)

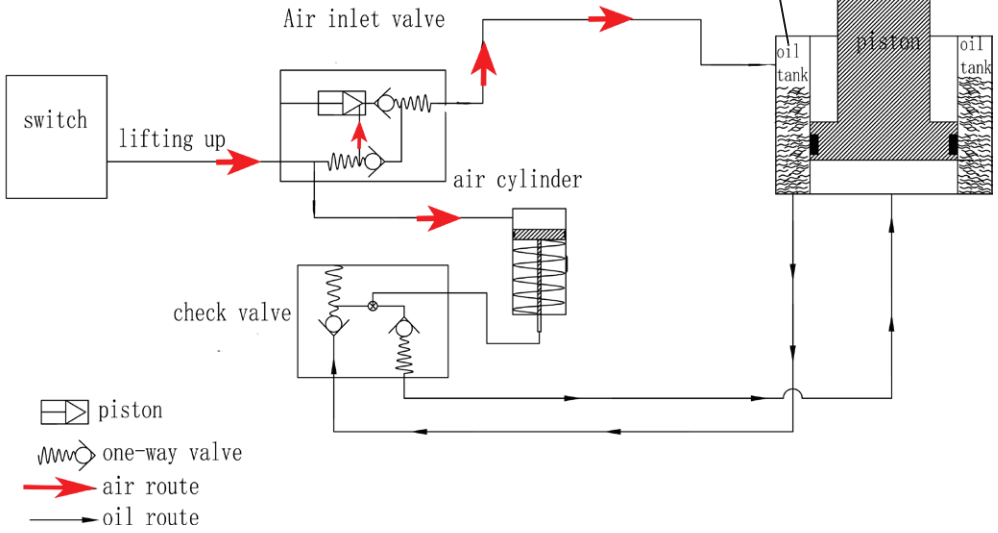
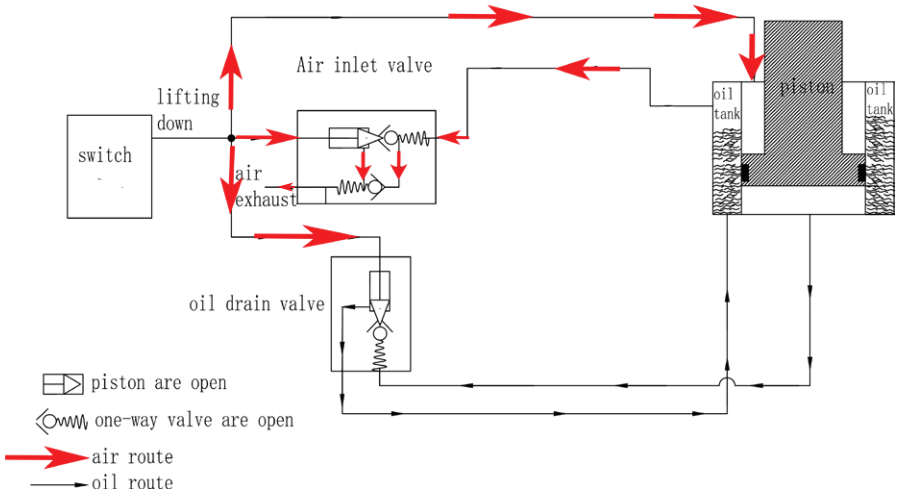

Fig. 05 & 06

working theory(lifting down)



Translation for Fig.05 & 06

	1	2	3	4	5	6	7	8	9	10
EN	Piston	One-way valve	air route	oil route	Air Inlet Valve	Air Cylinder	Check Valve	Oil tank	Working Theory (lifting up)	Working Theory (lifting down)

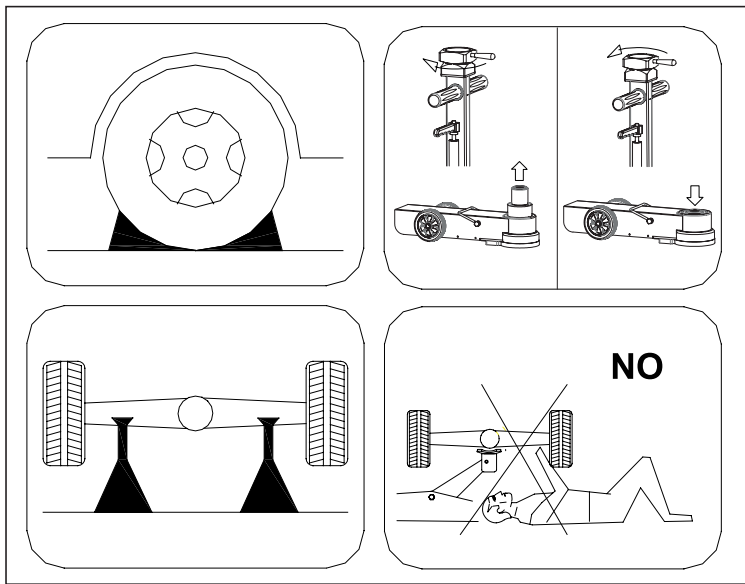

Fig. 07

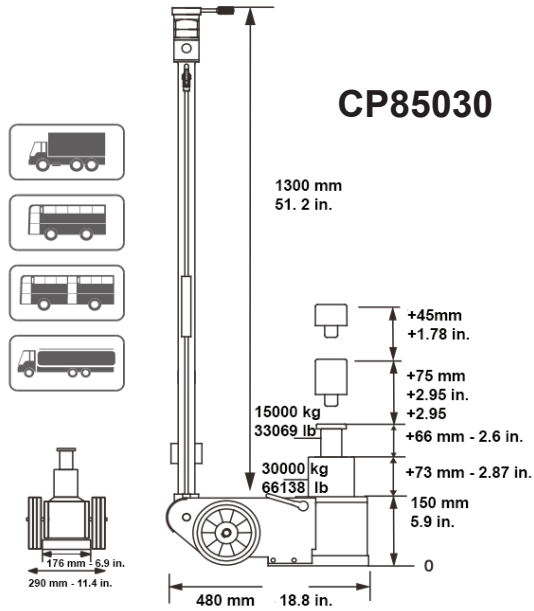

Fig. 08

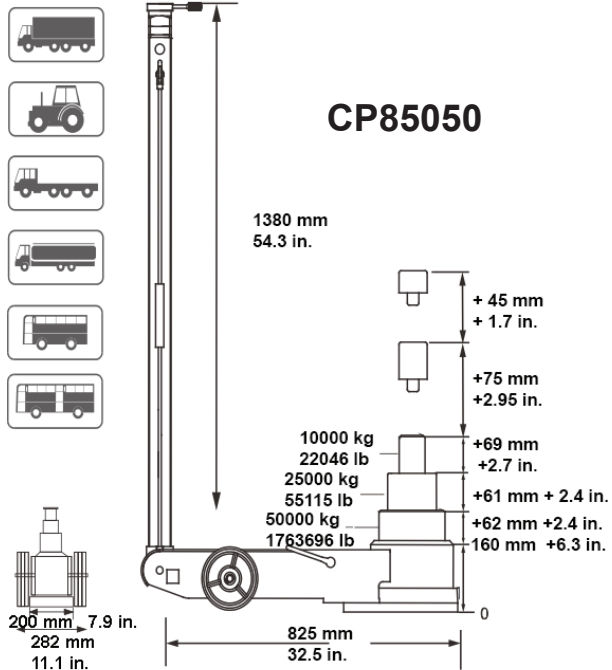

Fig. 09

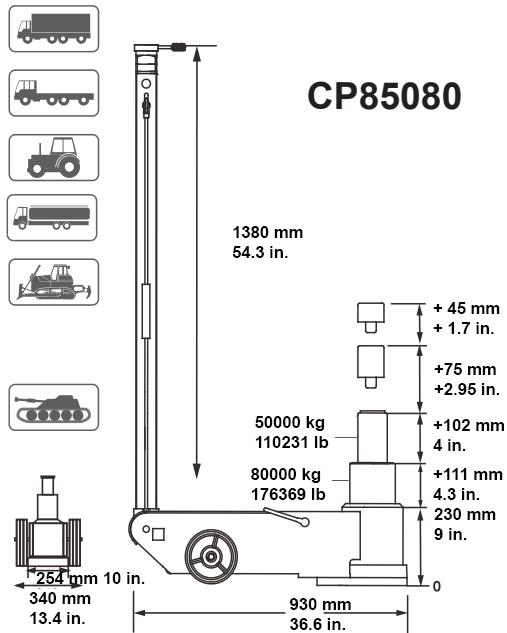
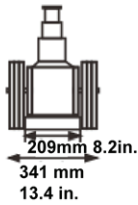
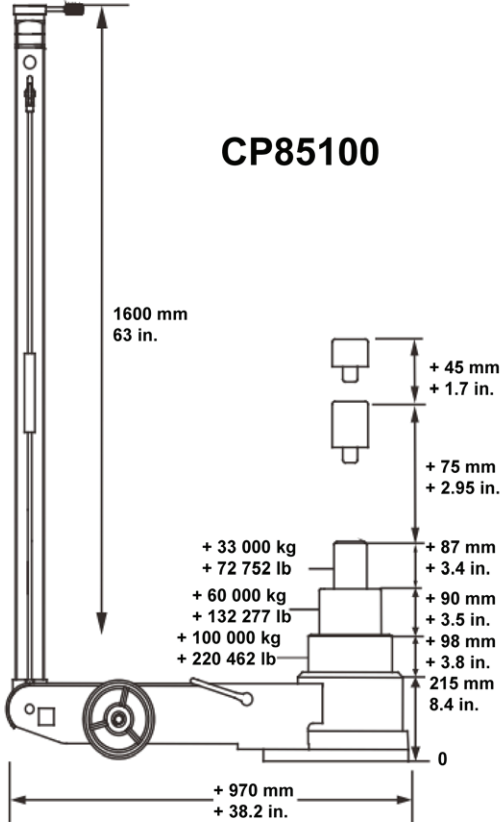

Fig. 10



CP85100



1. Technical Data (See figures 08, 09, 10 & 11)

	Max. Lifting capacity	Pressure	Air Consumption	Hydraulic oil Quantity ISO VG#15	Sound pressure	Weight
Unit	[kg] - [lb]	[bar]	[l/min] - [SCFM]	[l] - [oz]	dB	[kg] - [lb]
CP85030	30000 - 66138	8 - 12	10.5 - 0.37	0.9 - 30	70	38 - 83
CP85050	50000 - 110231	8.5 - 12	11.5 - 0.4	2.5 - 84	78	60 - 132
CP85080	80000 - 176369	9 - 12	11.5 - 0.4	6.2 - 209	77.8	103 - 227
CP85100	100000 - 220462	9 - 12	11.5 - 0.4	7.5 - 253	77.8	105 - 231

Static coefficient test: 1.5 / Dynamic Coefficient test: 1.2
All values are current as of the date of this publication.

Declaration of noise and vibration statement

These declared values were obtained by laboratory type testing in accordance with the stated standards and are suitable for comparison with the declared values of other tools tested in accordance with the same standards. These declared values are not adequate for use in risk assessments and values measured in individual work places may be higher. The actual exposure values and risk of harm experienced by an individual user are unique and depend upon the way the user works, the workpiece and the workstation design, as well upon the exposure time and the physical condition of the user. We, CHICAGO PNEUMATIC TOOLS, cannot be held liable for the consequences of using the declared values, instead of values reflecting the actual exposure, in an individual risk assessment in a work place situation over which we have no control. This tool may cause hand-arm vibration syndrome if its use is not adequately managed. We recommend a programme of health surveillance to detect early symptoms which may relate to noise or vibration exposure, so that management procedures can be modified to help prevent future impairment.

2. Machine type(s)

- An Air-Hydraulic jack is a device to lift a vehicle up to for accessibility during repair and maintenance.No other use permitted. For professional use only.
- A Jack is only a lifting device and should never be used for transporting and/or loading a vehicle. Lifting a vehicle with person inside is prohibited. Moving the jack with load is prohibited.
- Please read the instructions carefully before starting the machine.

3. Mounting instruction

 **WARNING** Make sure every parts are fixed and tightened.

- First loosen the screw attached to the frame. (see fig. 01)
- Connect the hose and the spring to the lifting device. For CP85050, CP85080 & CP85100 jack, the white hose is connected to the left inlet, the Black hose is connected to the right inlet.
- For CP85030 jack, the white hose is connected to the right inlet, the black hose is connected to the left inlet. (see fig.02)
- To assemble the handle, see figure 03.
- To install the control lever, loosen the screw and rotate the control lever into the hole. (see fig.04)
- Do a complete cycle of lifting and lowering with no load, to purge air from the hydraulic system.

 **Caution**

Working area of 1 m must be kept free both in front of and behind the machine while it is in operation so that it is always easily accessible.

4. Operation

- Verify the control lever is in the neutral position.
- Connect the shop air supply to the jack. Minimum air pressure is 8 bar for CP85030, 8.5 bar for CP85050, 9 bar for CP85080 and CP85100. Install an air filter/lubricator in the shop air line, because water in the air line will damage the jack.
- Move the control lever clockwise to raise the saddle to the contact point. Move the control lever to neutral position.
- Check the placement of the jack. The load must be centered on the jack saddle. Avoid jack wheel obstructions such as gravel, tools, or uneven expansion joints.
- Move the control lever clockwise to finish lifting the vehicle.
- Immediately place approved support stands under the vehicle's lifting points (recommended by the vehicle manufacturer).
- To lower the load, move the control lever counter clockwise.

 **WARNING**

- **Brake vehicle. Chock vehicle tires that are still in contact with the ground.**
- **SLOWLY and CAREFULLY lower the vehicle onto the support stands by pushing the control lever counter clockwise.**
- **It is not allowed to work under the raised load until it is secured by suitable means.**
- **The operator shall be provided with all necessary information about training and about pumping and translating forces.**

5. Maintenance instruction



- Do not use damaged/deformed product. If abnormal noise or vibration occurs, stop use immediately, then inspect and ask manufacturer for help. It is recommended that this inspection be made by a manufacturer's or supplier's authorized repair facility.
- **The greatest single cause of failure in hydraulic units is dirt. Keep the service jack clean and well lubricated to prevent foreign matter from entering the system. If the jack has been exposed to rain, snow, sand, or grit, it must be cleaned before it is used.**

- Store the jack, with pistons completely retracted, in a well-protected area where it will not be exposed to corrosive vapors, abrasive dust, or any other harmful elements.
- Periodically check the condition of the product.
- Store the product in dry and non-corrosion environment.
- Owners and/or operators should be aware that repair of this equipment may require specialized knowledge and facilities. It is recommended that an annual inspection of the product be made by a manufacturer's or supplier's authorized repair facility and that any defective parts, decals, or safety labels or signs be replaced with manufacturer's or supplier's specified parts. A list of authorized repair facilities is available from the manufacturer or supplier, please call them for help.
- Any product that appears to be damaged in any way, is found to be worn, or operates abnormally SHALL BE REMOVED FROM SERVICE UNTIL REPAIRED. It is recommended that necessary repairs be made by a manufacturer's or supplier's authorized repair facility if repairs are permitted by the manufacturer or supplier.
- Only attachments and/or adapters supplied by the manufacturer shall be used.

6. Trouble Shooting

	Fault	Cause	Remedy
A	The hydraulic piston is not rising up with or without load	1. Not enough air pressure supply to the jack 2. hydraulic piston is missing oil 3. Failure of the pneumatic pump	1.a Supply air pressure within the tolerances specify into the manual and on the product nameplate 1.b Confirm the pneumatic hoses are correctly connected to the tie-ins (Fig.02) 2.a fill-in tank with recommended hydraulic oil (ISO VG#15) 2.b failure of the hydraulic system, product to be repair by authorized repair center 3. Product to be repaired by authorized repair facility
B	The hydraulic piston is not reaching the maximum position	hydraulic piston is missing oil	Fill-in tank with recommended hydraulic oil (ISO VG#15)
C	The hydraulic piston cannot stand in upper position	1. hydraulic piston is leaking oil. 2. Failure of the pneumatic pump	1. Check the product to detect potential oil leakage from the piston. Send the product to authorized repair facility for reparation 2. Product to be repaired by authorized repair facility
D	The hydraulic piston is not going down	1. Not enough air pressure supply to the jack 2. Failure of the pneumatic pump 3. Air leakage from the dustproof gasket	1.a Supply air pressure within the tolerances specify into the manual and on the product nameplate 1.b Confirm the pneumatic hoses are correctly connected to the tie-ins (Fig.02) 2.&3. Product to be repaired by authorized repair facility

7. EC Declaration of conformity

Declare that the product(s): **CP85030 / CP85050 / CP85080 / CP85100** Serial Number: **001 - 999**
 Machine type(s): **Air Hydraulic jack**
 is in conformity with the requirements of the council Directives on the approximation of the laws of the Member States relating : to "Machinery"
2006/42/EC (17/05/2006)
 applicable harmonised standard(s) : **EN 1494:2000 + A1:2008**
 Name and position of issuer: **Pascal Roussy (R&D Manager)**

Copyright 2016, CHICAGO PNEUMATIC TOOL CO. LLC

All rights reserved. Any unauthorized use or copying of the contents or part thereof is prohibited. This applies in particular to trademarks, model denominations, part numbers and drawings. Use only authorized parts. Any damage or malfunction caused by the use of unauthorized parts is not covered by Warranty or Product Liability.

Original Instructions