



# Installation Instructions

PART NUMBERS: 76020, 84020,  
CQT76020

## Applications:

Years	Make	Models
2016-Current*	Mazda	CX-9

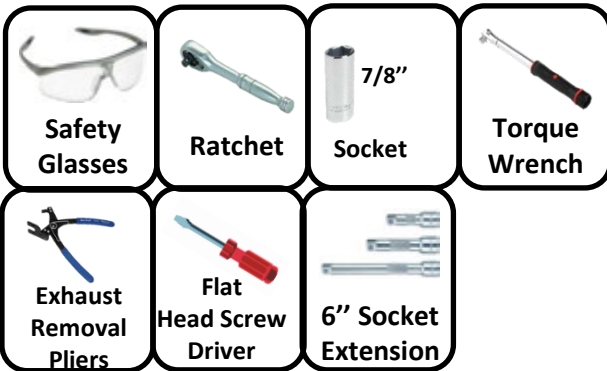
Installation Time: **30 min.**

The time listed above is the average time for professional installers. If you do not feel comfortable performing this installation on your own or are in need of assistance, please contact a professional installer.



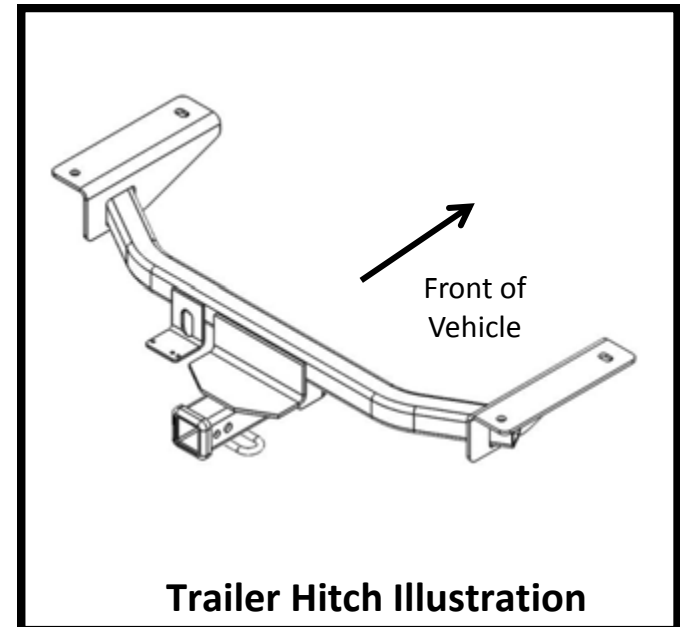
Representative Vehicle Photo

## Equipment Required:



**DO NOT EXCEED LOWER OF TOWING VEHICLE  
MANUFACTURER'S RATING OR:**

Hitch Type	Max Gross Trailer Weight	Max Tongue Weight
Weight Carrying	4500 lb. (2043 kg)	675 lb. (306 kg)
Weight Distributing	4500 lb. (2043 kg)	675 lb. (306 kg)








Trailer Hitch Illustration

**Always wear SAFETY GLASSES when installing hitch**

# Installation Instructions

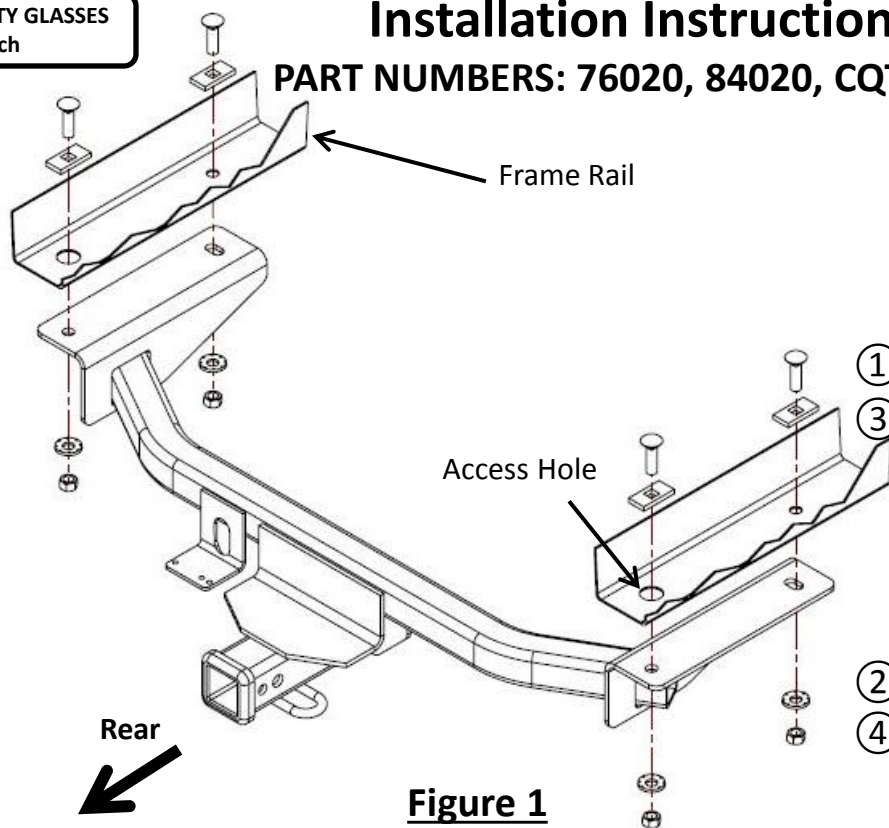
**PART NUMBERS: 76020, 84020, CQT76020**

**Fastener Kit: 76020F**

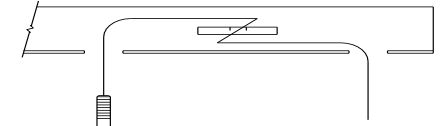
①	Qty. (4)	Carriage Bolt ½"-13 x 1.75 Gr8	
②	Qty. (4)	Conical washer 1/2"	
③	Qty. (4)	Block 1/4" x 1" x 3"	
④	Qty. (4)	Hex Nut ½"-13 Gr8	
⑤	Qty. (4)	Pull wire ½"	

**Conical Washer**  
Teeth side  
against hitch

**Fasteners**  
typical  
all locations

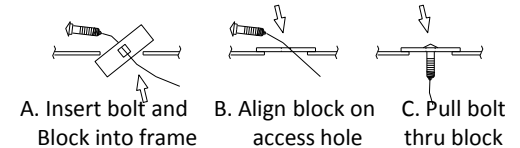


**Figure 1**



Kink pullwire to keep spacer independent of bolt

**Figure 2**



**Figure 3**

- 1. Remove Lower Trim Panel** - Remove plastic expanding fasteners to remove panel. Return to owner.
- 2. Lower exhaust** - Pry off (4) rubber exhaust hangers using exhaust removal pliers or other suitable tool (spray with soapy water to make this easier). Be sure to support exhaust system.
- 3. Fishwire forward bolts** - Using the fishwire method (Figure 2) install the carriage bolts and blocks through the access hole and into the forward attachment holes, leave pullwires attached.
- 4. Fishwire rearward bolts** - Using the reverse fishwire method (Figure 3) install the carriage bolts and blocks into the rearward attachment holes, leave pullwires attached.
- 5. Install hitch** - Raise hitch into position, guide the fishwire ends through the attachment holes, remove pullwire and install the conical washers (teeth side toward hitch) and ½" hex nuts onto the carriage bolts. Assure no wires or other items have been pinched between hitch and vehicle frame.
- 6. Tighten all hitch fasteners with torque wrench to 110 Lb.-Ft. (149 N\*M)**

**Proper torque is needed to keep the hitch secure to the vehicle when towing.**

- 7. Reinstall exhaust hangers** - Raise exhaust back into position and reinstall all exhaust hangers.

Note: check hitch frequently, making sure all fasteners and ball are properly tightened. If hitch is removed, plug all holes in trunk pan or other body panels to prevent entry of water and exhaust fumes. A hitch or ball which has been damaged should be removed and replaced. Observe safety precautions when working beneath a vehicle and wear eye protection. Do not cut access or attachment holes with a torch.

This product complies with safety specifications and requirements for connecting devices and towing systems of the state of New York, V.E.S.C. Regulation V-5 and SAE J684.

Learn more about trailer hitches and towing we have.