



Bulldog RV Landing Gear

Read, Understand, Follow and Save These Instructions

Read, understand and follow all of these instructions and warnings (Instructions) before installing and using this product. Install and use this product only as specified in these instructions. Improper installation or use of this product may result in property damage, serious injury, and/or death. Never allow installation or use of this product by anyone without providing them with these instructions. You must read, understand and follow all instructions and warnings for any product(s) to which this product is used in conjunction with or installed. Save these instructions with the product for use as a reference for any future installation and use of the product.

WARNING Failure to follow all warnings and instructions may result in product failure, property damage, serious bodily injury, and/or death.

- This product must be installed and used in strict accordance with these instructions. Purchaser/owner must not alter or modify the product.
- Operator and bystanders should never position any part of body under or on the path of any portion of this product or the load being supported, or moved.
- Do not allow children to play on or around this product or the load being supported, or moved.
- Never exceed the maximum rated capacity. Refer to stamped markings or decals to obtain rated capacity.
- Periodically check mounting hardware for proper torque and tighten if necessary.
- Always replace bent, broken, or worn parts before using this product.
- To avoid accidental shock and/or damage to the electrical system, disconnect the battery ground cable before installation.
- When using the drop foot or drop leg, make certain the supplied pin is fully inserted through both sides of the inner tube and the drop tube before using the jack.
- Secure the load, vehicle and trailer from rolling (by blocking wheels) when operating jack or coupling trailer.
- These jacks are designed for vertical loading. Excessive side forces may cause jack failure and must be avoided.
- If this product has a drop foot or drop leg, never attempt to adjust the drop foot or drop leg when there is any load on the jack.
- All welding must be performed by a certified AWS welder.

Installation Instructions

Warning: Failure to follow all warnings and instructions may result in product failure, property damage, serious bodily injury, and/or death.

All welding must be performed by a certified AWS welder. Use caution during installation to ensure the motor does not receive sharp blows or other stresses due to a drop, tip over, etc.

- 1) Position weld brackets to frame in such a manner so that welded tabs on jack are captured as shown (Fig. 1).
- 2) Affix weld brackets to frame member using 1/4" fillet welds on both sides.
- 3) Secure the jack to the brackets with supplied carriage bolts and nuts. Torque to 25 ft-lbs.

Traditional Landing Gear Configuration.

Install gear reducer box onto the jack with the longer input shaft. Use supplied screw and plastic retainer to secure reducer to jack input shaft.

Attach electric gear motor to the reducer box using supplied machine screws.

Install the telescoping cross shaft between the jacks. Dual motor kits do not include cross shaft.

Install pull-pin assemblies (if included) to bottom of inner tube using supplied hardware. Torque bolts to 15 ft-lbs.

Install foot plates to jack tube with supplied lynch pins.

Mount switch and connect wires according to attached wiring instructions.

Traditional LG Wiring *Required wire gage 10 AWG minimum for all RV landing gear wiring connections*

The shorter PINK (+) and BLACK (-) leads from the switch connect directly to the battery terminals.

The longer RED (+) and BLACK (-) leads from the switch connect to the RED and BLACK motor leads. Connect like color wires together.

500168 uses two switch assemblies, one for each drive motor.

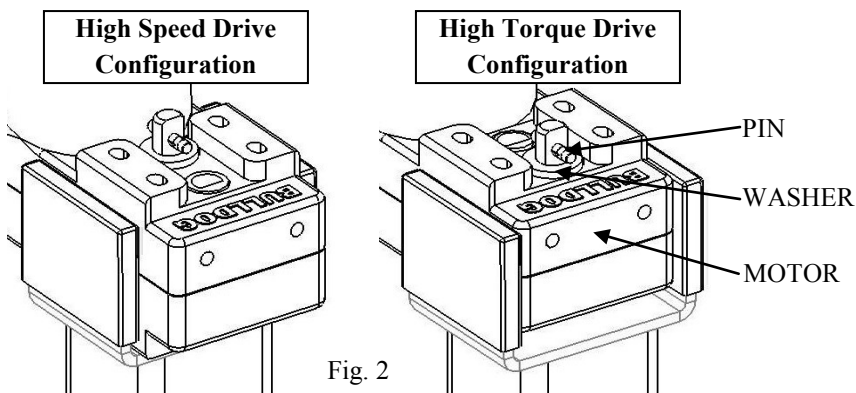

Fig. 2

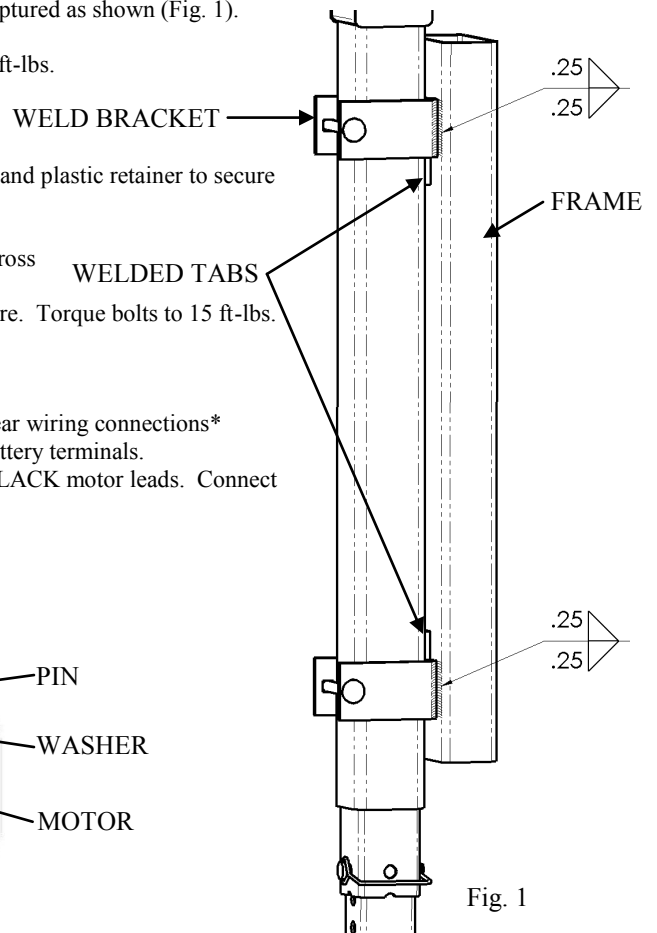

Fig. 1

Dual Output Powered Drive Landing Gear.

Install footplates to drop tubes with supplied lynch pins.

Disconnect the battery ground cable(s).

Use the attached template for installing the switch and carefully route the wires to avoid the possibility of chafing.

Use plastic loom (not included) if necessary to protect wires.

Refer to the attached wiring diagrams for correct wiring instructions. **NOTE:** High Speed Drive and High Torque Drive variations (Fig. 2) are not wired alike.

Reconnect the ground cable to the battery and test both jacks to ensure they travel in the correct EXT (extended) and RET (retracted) directions.

To reset the overload circuit breaker, push in the respective button.

In the event of a vehicle power loss or motor malfunction, insert the special Emergency Override Crank bolt (3/4" hex head) included into the open drive hole on the motor and crank the jack manually using a ratchet or similar tool.

Dual Output Motor Replacement.

Disconnect motor wires.

Rotate motor with override crank bolt until pin is at a 45 degree angle enabling pin removal (Fig. 3).

Tap out pin from drive shaft and remove pin and washer.

Replace new electric gear motor.

Replace washer and pin to drive shaft.

Connect motor wires to mount switch according to attached wiring instructions.

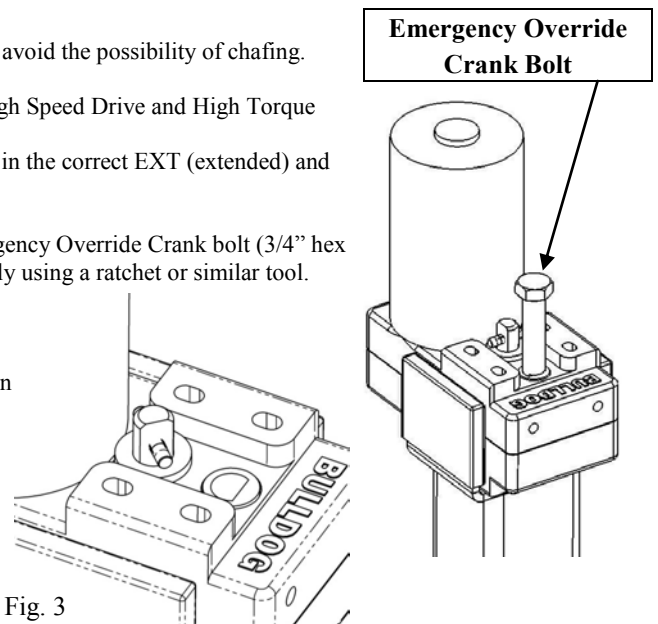
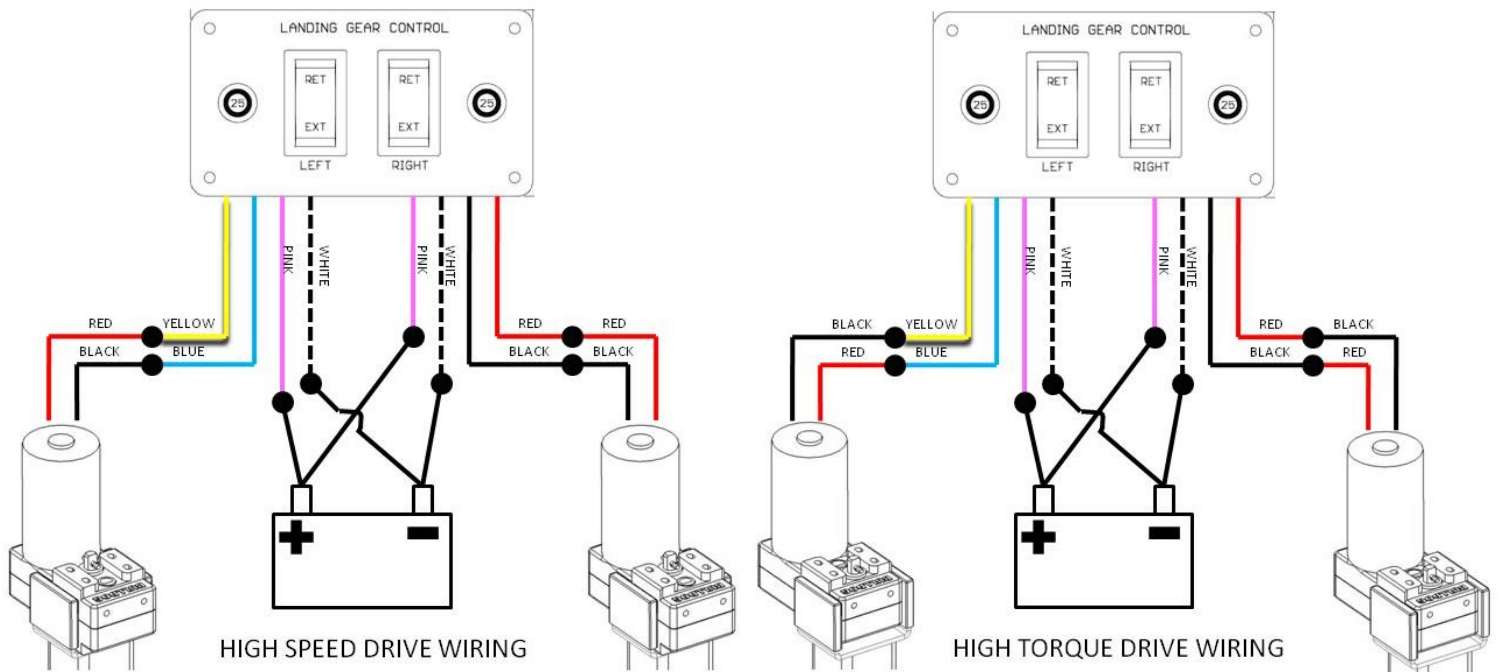

Fig. 3

Dual-Drive Wiring Instructions

High Speed Wiring Schematic *Required wire gage 10 AWG minimum for all RV landing gear wiring connections*

- Connect both PINK wire leads from the switch panel directly to the POSITIVE (+) battery terminal
- Connect both WHITE wire leads from the switch panel directly to the NEGATIVE (-) battery terminal
- Connect the YELLOW wire lead from the switch panel to the RED motor lead on the left side jack
- Connect the BLUE wire lead from the switch panel to the BLACK motor lead on the left side jack
- Connect the RED wire lead from the switch panel to the RED motor lead on the right side jack
- Connect the BLACK wire lead from the switch panel to the BLACK motor lead on the right side jack



High Torque Wiring Schematic *Required wire gage 10 AWG minimum for all RV landing gear wiring connections*

- Connect both PINK wire leads from the switch panel directly to the POSITIVE (+) battery terminal
- Connect both WHITE wire leads from the switch panel directly to the NEGATIVE (-) battery terminal
- Connect the YELLOW wire lead from the switch panel to the BLACK motor lead on the left side jack
- Connect the BLUE wire lead from the switch panel to the RED motor lead on the left side jack
- Connect the RED wire lead from the switch panel to the BLACK motor lead on the right side jack
- Connect the BLACK wire lead from the switch panel to the RED motor lead on the right side jack

Maintenance

It is important to maintain the electrical system including the battery and charger (not included). Ensure all connections are tight and free of corrosion. Make sure the battery is fully charged prior to use. Do not direct a high pressure spray at the electric motors or switch assemblies. Do not use if parts are worn, bent, broken or if product has been modified or altered.