



# Powered Drive for Bulldog Jacks

## **Read, Understand, Follow and Save These Instructions**

Read, understand and follow all of these instructions and warnings (Instructions) before installing and using this product. Install and use this product only as specified in these instructions. Improper installation or use of this product may result in property damage, serious injury, and/or death. Never allow installation or use of this product by anyone without providing them with these instructions. You must read, understand and follow all instructions and warnings for any product(s) to which this product is used in conjunction with or installed. Save these instructions with the product for use as a reference for any future installation and use of the product.

## **WARNING**

**Failure to follow these warnings and instructions may result in property damage, serious bodily injury, and/or death.**

- Purchaser/owner must ensure that product is installed according to these instructions. Purchaser/owner must not alter or modify product.
- Operator and bystanders should never position any part of body under any portion of this product or the load being supported.
- Fully retract and/or rotate jack before towing.
- When using the drop leg, make certain the drop leg pin is fully inserted before using the jack.
- Do not allow children to play on or around this product or the load being supported.
- Secure the load, vehicle and trailer from rolling (by blocking wheels) when operating jack or coupling trailer.
- Jack capacity is limited to the lesser of the jack, footplate, or caster wheel capacity.
- Never exceed maximum rated capacity. Refer to stamped markings or decals on product to obtain rated capacity.
- These jacks are designed for vertical loading. Excessive side forces may cause jack failure and must be avoided.
- If this product has a pivot tube mount, make certain the pivot pin is fully inserted through both sides on the pivot tube and the pivot mount.
- If this product has a drop leg, never attempt to adjust the drop leg when the jack is under load.
- These jacks are designed for mounting to flat surfaces only.
- Keep clear of pinch point at drop leg pin. The drop leg will naturally drop or retract very quickly depending on model.
- Keep clear of holes in drop leg.
- All welding must be performed by an AWS certified welder.
- Always replace bent, broken, or worn parts before using this product.
- To avoid accidental shock and/or damage to the electrical system, disconnect the battery ground cable before installation.

## **Installation Instructions**

**Warning: Failure to follow these warnings and instructions may result in property damage, serious bodily injury, and/or death.**

### Instructions for Field Installation:

1. Remove the jack cross shaft. If your jack has non-welded hex bushings, refer to Service Bulletin F3310 (included). If you are installing the powered drive on a planetary two speed jack, refer to Service Bulletin F3376 (included). Refer to steps #1 through #5 for instructions on removing the cross shaft.
2. If your date code is before E06 (May 2006), then you will also need to change out the bevel gear (included) to accommodate the larger dowel pin (included). The date code is stamped on the outer tube. The letter of the date code corresponds to the month of manufacture (A thru N; A means January) and the numbers correspond to the year (i.e. 06 means 2006). The dowel pin hole in the screw rod will need to be drilled out to 5/16" to accommodate the larger dowel pin (enclosed). Please refer to the appropriate Service Bulletin (see above) for the disassembly procedure.
3. Replace the jack cross shaft temporarily with the powered drive/shaft. Install the shaft such that the powered drive is on the non-gear side of the jack with the motor down and within the profile of the jack (see Fig. 1). For a tandem jack system, the powered drive should be between the two jacks and installed on the "street-side" jack. For the tandem two-speed installation, the grease zerks will no longer be easily accessible. Your option is to drill two 1/4" holes on an accessible side of the jack outer tube, and install new grease zerks (not included). Proceed with torque stop tube attachment.
4. With the powered drive/shaft temporarily installed, use it to locate the torque stop tube on the jack outer tube wall (see Fig. 1).
5. Place the torque stop tube on the rubber bumper (with the powered drive/shaft installed into the jack) and mark the location of the torque stop tube on the outer tube of the jack. Remove the powered drive/shaft and weld the torque stop tube on to the jack outer tube at your marked location (see Fig. 1).
6. Replace the powered drive/shaft. Make sure to place the energy-absorbing rubber bumper into the torque stop tube when assembling. This prevents the motor from rotating. Follow instructions of the appropriate Service Bulletin (see above) in reverse order to reassemble the jack. Use the standard hole for normal installation (see Fig. 2; do not use hole #2).
7. Attach the powered drive cover using the 1/4" x 1" bolts and 1/4" rubber bonded washers (included). Sandwich the cover between two rubber bonded washers on each bolt with the rubber side against the cover. Then, screw the bolts into the mounting flange holes. Torque the bolts to 6 ft. lbs. Your option is to apply a thread lock or retaining compound (not included) to the bolts. Place Bulldog decal (included) on outside of cover.

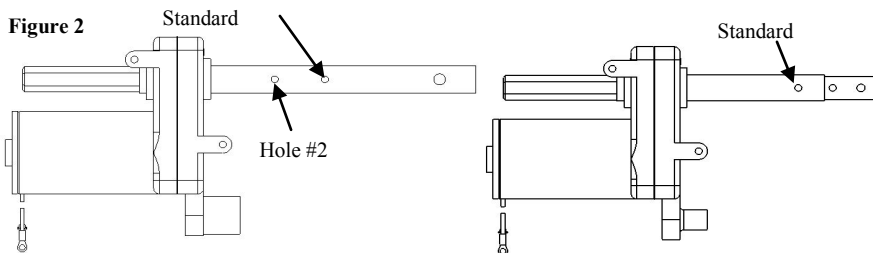
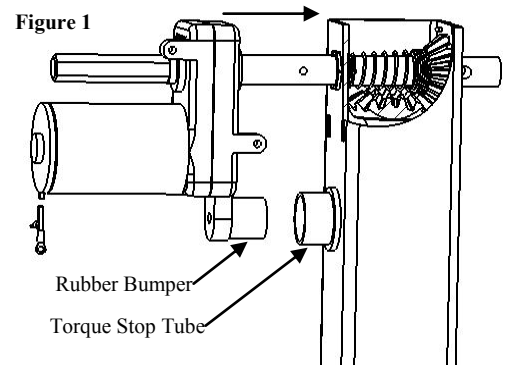

Powered Drive - Single Speed Jack

Powered Drive - Two Speed Jack

8. If you plan to run tandem jacks from the powered drive, you will need to use the hex coupling (included). This coupling can be welded to a length of 1 inch Schedule 40 pipe (see Figure 3). Slide the hex coupling end of the pipe over the hex shaft of the powered drive. Cut the other end of the pipe such that it will just clear the end of the second jack's cross shaft. Cross drill a  $\frac{3}{8}$ " hole approximately 1 inch from the end of the pipe. Slide the pipe over the second jack's cross shaft and attach with a  $\frac{3}{8}$ " x 2" long bolt and lock nut, Grade 5 (not included; see Figure 4). Torque to 18 ft. lbs. Make sure the jacks are in the same position in reference to the ground prior to final connection.

**Figure 3**

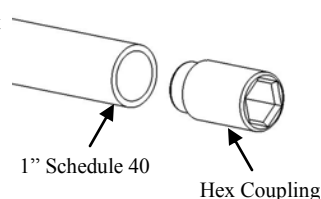

**Figure 4**

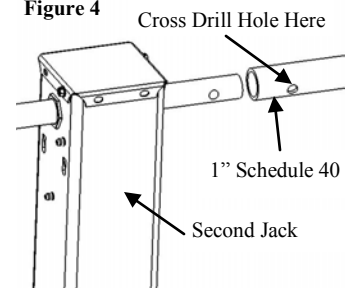

Wiring Instructions:

9. To avoid accidental shock and/or damage to the electrical system, disconnect the battery ground cable.
10. Attach the terminal box to the trailer at a location that will allow for connection of the powered drive leads to the terminal box studs. See wiring diagram (Figure 5).
11. Attach the powered drive leads and the wiring harness leads to the terminal box studs. To protect the leads, enclose them in a section of non-split tubing or loom (included).
12. Locate and attach the switch box of the wiring harness at a desired location on the trailer (mounting hardware not included).
13. Attach the battery leads to the terminal box studs. Attach the terminal box cover.
14. Reconnect the battery ground and test the operation of the powered drive. Apply sealant (not included) to all terminal box entrances.

**Figure 5**

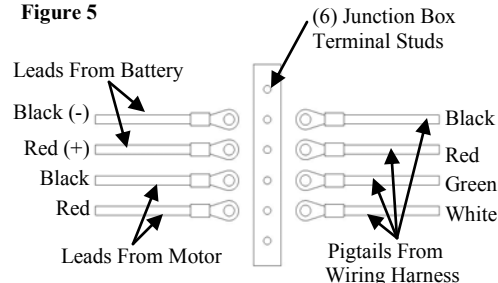

## **Operation**

1. To raise the trailer off of the ball, extend the drop leg(s) and fully engage the drop leg pin(s). Make sure the coupler is open, then push the "RAISE" end of the rocker switch. Continue raising until the ball completely clears the coupler.
2. To lower the trailer on to the ball, make sure the coupler is open and aligned with the ball, then push the "LOWER" end of the rocker switch. Continue lowering until the ball engages the coupler and the weight of the trailer is no longer resting on the jack. Then, close the coupler and fully retract the jack and the drop leg(s).
3. If for any reason electric power is lost, push to reset the breaker. If there is a different electrical malfunction (i.e. dead battery), the jack can still be manually cranked through the powered drive.

## **Maintenance**

The powered drive is sealed and maintenance-free. Regular maintenance of the jack should be followed as per the jack's instruction sheet. It is important to maintain the electrical system including the battery and charger (not included). Ensure all connections are tight and free of corrosion. Make sure the battery is fully charged prior to use.