

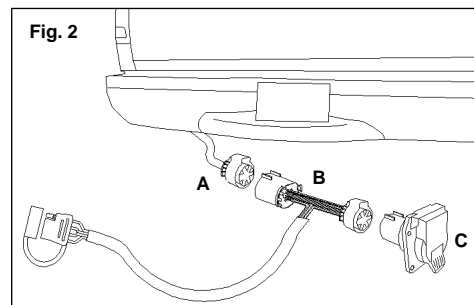

Installation instructions

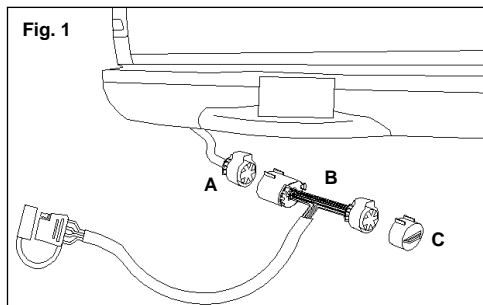

For Vehicles without a Factory 7-Way (Fig. 1):

1. Locate the tow vehicle's trailer harness connector **A**. This harness is located under the vehicle, behind the bumper, on the driver's side of the vehicle (Fig 1).
2. Remove protective cap **C** (and save) from connector **A**; check to see that the mating surfaces of the connectors are free or dirt. Clean if necessary (Fig 1).
3. Connect the T-connector adapter end **B** to the vehicle's connector **A**. Be sure that the T-connector is fully inserted with locking tabs in place.
4. Place protective cap **C** on remaining plug end (Fig 1). Skip to step 8 for remaining installation instructions.

For Vehicles with a Factory 7-Way (Fig. 2):

5. Locate the Factory 7-Way attached to the hitch on the driver's side.
6. Separate the factory socket **A** and 7-Way **C**.
7. Plug the T-Connector **B** between the Factory socket and 7-Way.
8. Test the installation with a test light or trailer.

This unit is rated for **7.5** amps per circuit.