

Installation instructions

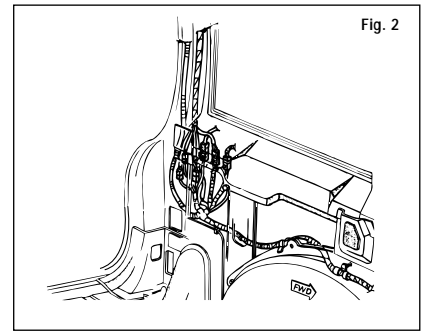

- 1.** Open rear door of vehicle. Temporarily remove spare tire and rear quarter panel trim located on driver's side (Fig. 1).
- 2.** Locate the vehicle's tail light wiring harness with white rectangular connectors matching the ends of the T-Connector (Fig. 2). Separate the harness connectors, being careful not to break the locking tabs.
- 3.** Insert the T-Connector between the harness connectors and lock into place. Be sure that connectors are fully inserted with locking tabs in place.
- 4.** Locate a suitable grounding point near the adapter. (Do not drill into vehicle floor or bed). Clean dirt and rustproofing from the area. Drill a 3/32" hole and secure the white wire using the eyelet and screw provided.
- 5.** Test the installation with a test light or trailer. Secure the black box to the vehicle using the screw or cable tie provided. Reattach the rear quarter panel trim and spare tire to their original positions.

This unit is rated for 4 amps per circuit.

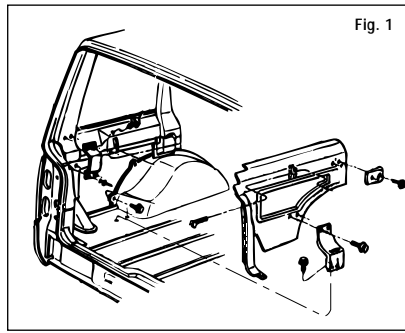