

## Installation instructions

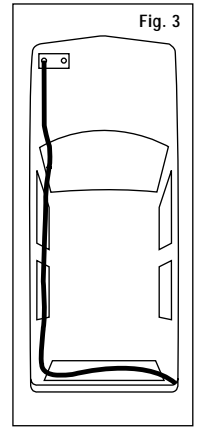

1. Read all instructions thoroughly before beginning.
2. Open the rear tailgate of the vehicle. Remove the two taillights by loosening the two screws on each assembly.
3. Stretch the T-connector wiring harness out across the bumper of the vehicle, placing the connector containing the Green wire on the right (passenger's) side.
4. Beginning on the left (driver's) side, route the black box and the connectors containing the Yellow and red wires up through the access hole underneath the vehicle and out through the taillight opening (Fig. 1).
5. Disconnect the top gray taillight socket, being careful not to break the locking tabs. Plug the T-connector containing the Yellow wire between these separated halves. Next, disconnect the center black taillight socket and plug the T-connector containing the red wire between these halves. Be sure that all connectors are fully inserted with locking tabs in place.
6. Drill a  $\frac{3}{32}$ " hole in the metal cross brace inside the taillight opening (Fig. 2). Secure the white wire using the eyelet and screw provided.
7. Route the Green wire across the vehicle and up into the passenger's side taillight opening from underneath the vehicle. Disconnect the top gray taillight socket, being careful not to break the locking tabs. Plug the T-connector containing Green wire between these separated halves.
8. Disconnect the vehicle's Negative (-) battery cable and remove the fuse from the supplied fuse holder. Using the ring terminal provided, attach one end of the fuse holder to the vehicle's Positive (+) battery cable. Connect the other end of the fuse holder to the black 12 ga. wire included with the T-connector using the supplied Yellow butt connector.
9. Beginning from the front of the vehicle, route the 12 ga. wire rearward along the driver's side frame rail and up through the access hole from step 4, avoiding any hot pipes, heat shields, the fuel tank or any other points that may pinch or break the wire (Fig. 3).
10. Attach the black 12 ga. wire to the wire on the T-connector adapter's black box labeled "Battery +" using the butt connector provided. Reconnect the vehicle's negative battery cable and install the 10 amp fuse into the fuse holder from step 8.
11. Test the installation with a test light or trailer. Secure all loose wires with the cable ties provided. Clean a flat area near the black box using a mixture of rubbing alcohol and water. Mount the black box to the clean area using the foam tape provided.
12. Route the 4-flat connector down through the taillight opening access hole and secure under the vehicle. **Option:** Remove the access panel exposing the vehicle's jack storage compartment. Slit the grommet between the taillight opening and the jack storage compartment and push the 4-flat connector through for storage.
13. Reattach the access panel and taillight housings to their original positions.

This unit is rated for 4 amps per circuit.

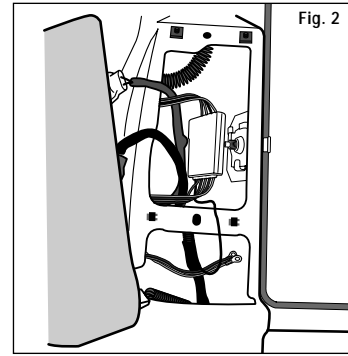
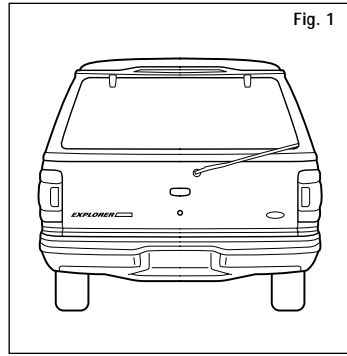