

## Installation instructions

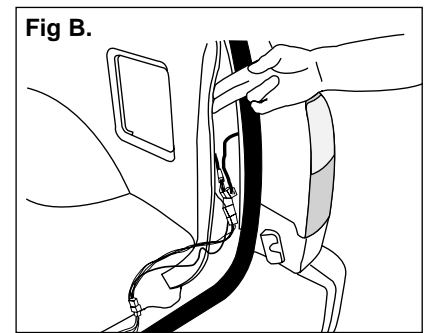

1. Open the rear door of the vehicle and remove the five screws attaching the threshold panel.
2. Remove the shade latch screws found on each side of the vehicle as illustrated (Fig. A) and carefully pull the plastic trim panels away from the side of the vehicle to expose the vehicle wiring (Fig.B).
3. Locate the vehicle's tail light wiring harness. This harness will have connection points on both sides of the vehicle with connectors matching the ends of the T-connector adapter.
4. Separate the harness connectors on the left (driver's) side of the vehicle, being careful not to break the locking tabs.
5. Insert the T-connector harness with the yellow wire between the harness connectors and lock into place. Be sure that the connectors are fully inserted with locking tabs in place.
6. Repeat steps 4 & 5 for the right (passenger) side using the connector containing the green wire.
7. Locate a suitable grounding point near the connector such as the vehicle's frame or cross member. (Do not drill into vehicle floor or bed.) Clean dirt and rustproofing from area. Drill a 3/32" hole and secure White wire using eyelet and screw provided.
8. Test the installation with a test light or trailer.
9. Route the Yellow wire under the threshold panel. Secure the threshold and side panels with screws removed in steps 1 & 2.

This unit is rated for 4 amps per circuit.

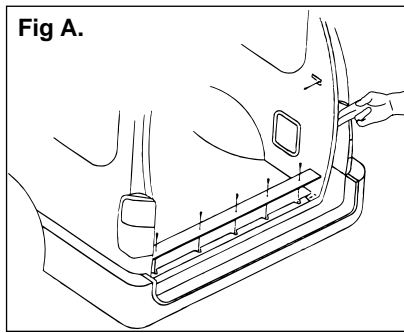