

Installation instructions

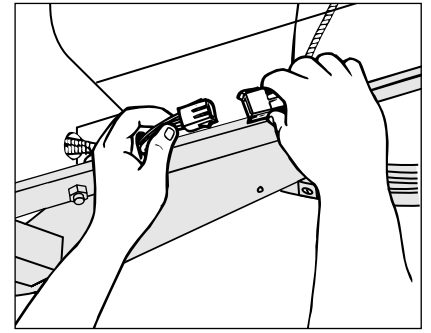
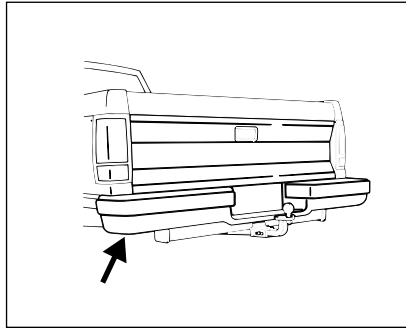

1. Locate the vehicle's tail light wiring harness along the inside of the left rear frame rail. This harness will have a connection point with connectors matching the ends of the T-connector.

2. Separate the harness connectors, being careful not to break the locking tabs. Check to see that the mating surfaces of the connectors are free of dirt and clean if necessary.

3. Insert the T-connector adapter between the harness connectors and lock into place. Be sure that connectors are fully inserted with locking tabs in place.

4. Locate a suitable grounding point near the connector such as the vehicle's frame or cross member. (Do not drill into vehicle floor or bed.) Clean dirt and rustproofing from area. Drill a 3/32" hole and secure white wire with eyelet using screw provided.

5. Route the T-connector harness to the center of the vehicle and secure wire to vehicle cross member or other mounting point using electrical tape or tie straps (not supplied).

6. Test the installation with a test light or trailer.

This unit is rated for **7.5** amps per circuit.

