

Installation Instructions

T-Connector



Kia Sorento



Hyundai Veracruz

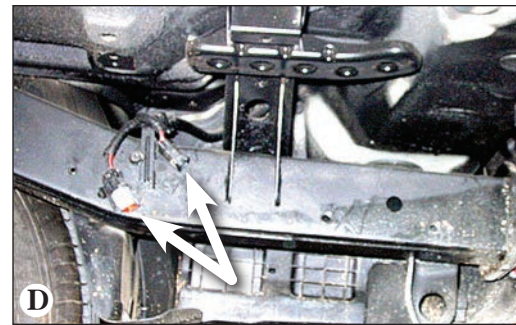
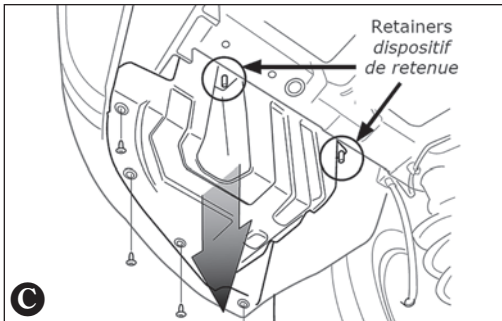
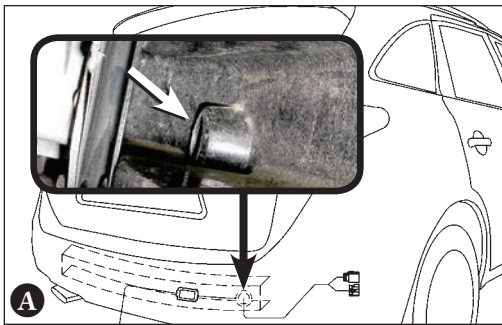

TOOLS REQUIRED:

Trim Panel Remover, Wire Cutters, 10mm Socket & Ratchet or 10mm Wrench, Philips Head Screwdriver, Test-probe

1. KIA Sorento:

Lower spare tire to gain access to vehicle wiring.

Hyundai Veracruz:

Find access hole inside the bumper support channel, above passenger side exhaust, and route T-Connector harness plugs through hole **A**.

2. KIA Sorneto:

Underneath the vehicle, on the passenger's side, on top of the frame rail near the rear tire, locate the vehicle Tow-Plug harness. It will have a connection point matching the T-Connector harness. Remove protective cap, being careful not to break the locking tabs. All connector surfaces should be clean and free of dirt **B**.

NOTE

On some vehicles, the vehicle wiring harness is located behind a protective cover on the drivers side frame rail. Remove the plastic trim fasteners, securing the protective cover, to access vehicle's wiring harness. **C**.

Hyundai Veracruz:

Locate the vehicle Tow-Plug harness underneath the vehicle, on the passenger's side frame, near the rear tire. It will have a connection point matching the T-Connector harness. Remove protective cap, being careful not to break the locking tabs. All connector surfaces should be clean and free of dirt **D**.

- Remove the vehicle tow plug protective caps and return to customer. All connector surfaces should be clean and free of dirt. Insert the T-Connector harness into the vehicle's Tow-Plug harness and lock into place. Be sure that connectors are fully inserted with locking tabs in place.

4. KIA Sorneto:

Route the T-Connector harness rearward to the back of the fascia of the bumper. Route the T-Connector harness along the inside of bumper toward the center of vehicle **E**.

Hyundai Veracruz:

Route the T-Connector harness along the inside of bumper support channel toward the center of vehicle. Mount the 4-Flat end in an accessible location with a bracket or electrical box (not included) **F**.

⚠ WARNING

Route the wire being careful to avoid any hot pipes, heat shields, the fuel tank or any other points that may pinch or break the wire.

- Mount the T-Connector black box using double-sided tape provided onto the bottom of the bumper support channel. Secure all loose wires with cable ties **G**.
- All connections must be complete for the T-Connector to function properly. For initial test, reset vehicle electrical system by temporarily removing the key from the ignition. Test and verify installation with a test light or trailer once installed.

⚠ WARNING

Overloading circuit can cause fires. DO NOT exceed lower of towing manufacturer rating or:

- Max. stop/turn light: 2 per side (4.2 amps)
- Max. tail lights: (7.5 amps)

Read vehicle's owners manual & instruction sheet for additional information.