

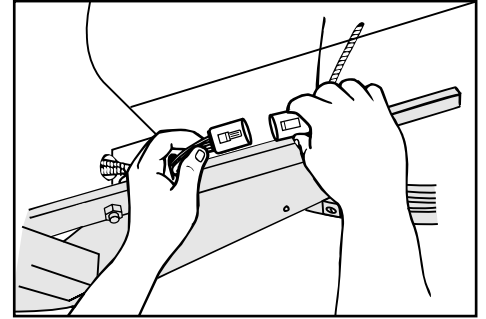

Installation instructions

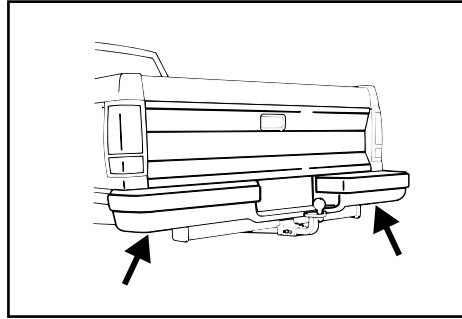

1. Locate the vehicle's factory tow harness connector behind the bumper. (Ranger left side), (Explorer right side) This harness will have a connector that will mate to the end of the tow plug.

2. Remove factory tow harness protective cap and check to see if the mating surface is clean and free of dirt, clean if necessary. Insert the tow plug into the connector.

3. Test the installation with a test light or a trailer.

4. Secure all loose wires with cable tie provided.

Note: This unit is rated for **7.5** amps per circuit.