



Bulldog® Gooseneck Coupler

Read, Understand, Follow and Save These Instructions

- Read, understand and follow all instructions before installing and using this product. Never allow anyone unfamiliar with these instructions to use this product.
- Read, understand and follow all instructions provided by the manufacturer of the product(s) on which this product will be installed.
- Installation of this product must conform to the following mounting instructions.
- Save these instructions for use as a reference in the future.

WARNING

Failure to follow these warnings and instructions may result in property damage, serious bodily injury, and/or death.

- Purchaser/owner must ensure that product is installed according to these instructions. Purchaser/owner must not alter or modify the product.
- Operator and bystanders should never position any body part under any portion of this product or the load being supported.
- Do not allow children to play on or around this product or the load being supported.
- Weigh your trailer plus added load. Do not exceed the lesser of coupler, hitch, vehicle, ball, or trailer weight ratings (including load).
- Use only a 2 5/16" ball rated equal to or greater than the capacity of this coupler.
- Always secure load, vehicle and trailer (by blocking wheels) before latching/unlatching coupler.
- All hardware must be torqued to 125 ft. lbs. minimum. Periodically check for proper torque and tighten if necessary. Check for wear on inner tube if retightening is needed.
- If equipped with a load bearing pin, it must be fully inserted through both the inner and outer tubes in order for the coupler to support its rated load.
- Do not tow unless the load bearing pin is fully inserted and retaining pin is installed.
- Do not exceed the 8" maximum extension for this gooseneck coupler. Measure the coupler extension as the difference between fully retracted and fully extended positions. Couplers with properly installed load bearing pins and square adjustable gooseneck couplers only extend within this range.
- Keep the ball pocket, latch, and handle clean.
- All welding must be performed by an AWS certified welder.
- This product rated according to SAE J2638.

Before Towing:

- Check vehicle, hitch ball and coupler for signs of wear or damage. Ensure that the coupler opens, closes, and the handle springs closed when released.
- Replace bent, broken, or worn parts before using this product. Ensure that the hitch ball is fully seated in the coupler ball pocket and the latch is closed.
- Make sure that the trailer safety chains are properly connected to the towing vehicle and trailer.
- Make sure that all trailer lighting is hooked up and working properly.

Installation Instructions

Warning: Failure to follow all installation instructions could result in coupler failure

Before mounting the coupler confirm that there will be no interference from the tow vehicle, tongue, ground, and any other mounted accessories while stationary or in motion. The set bolts(s) must be facing the towing vehicle. Before installing, check for interference in extended and retracted positions. Check for interference again after installation is complete. Weld size, gusseting requirements, coupler height, and orientation are dependent on trailer design and customer requirements, however, the outer tube must be supported completely by attaching gussets as low as possible to the outer tube. Avoid heat damage to coupler during welding, and do not weld over or near any holes or hardware on the coupler. All welding must be performed by an AWS certified welder. The outer tube must be rigidly attached to the trailer in order for the coupler to support its maximum rated load according to SAE J2638. Coupler must remain vertical after installation to ensure proper operation. After installation, check to make sure that coupler operation has not been impaired in any way. Do not use coupler if its operation has been impaired. After assembly and painting, but prior to being used, any enclosed labels must be affixed to the coupler and pre-mask removed.

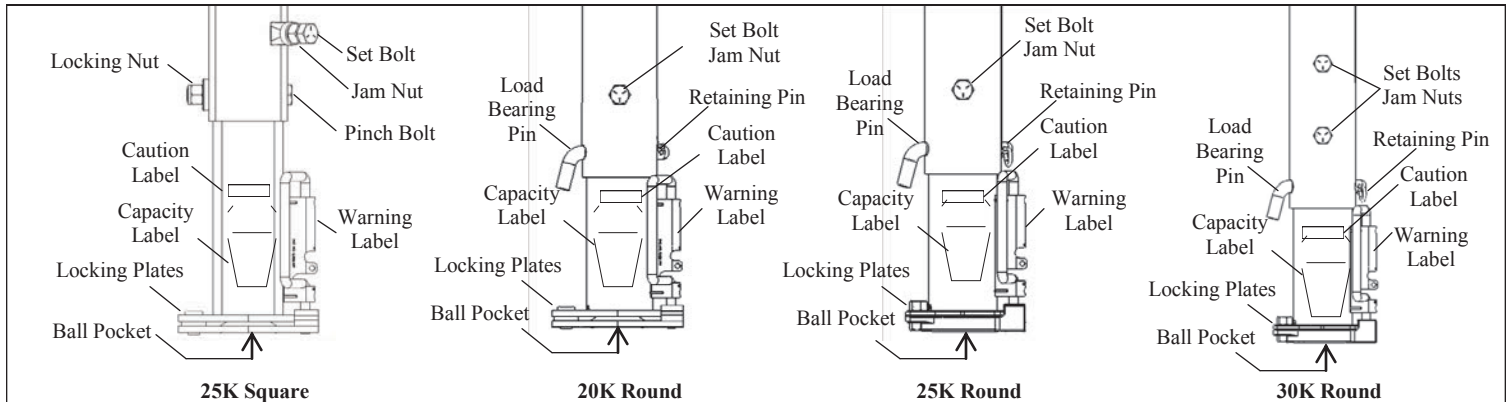

Gooseneck Coupler Installation Guidelines:

- 1) Be sure that the coupler will reach the towing vehicle to couple with the hitch ball while the load bearing pin is installed properly, or within the extension of the coupler if the coupler is a square adjustable gooseneck. If equipped with a load bearing pin/pinch bolt, it must be fully inserted through both the inner and outer tubes and the retaining pin/locking nut installed in order for the coupler to support its rated load.
- 2) Tighten the set bolt(s) and nut(s) to minimize vibrations in the coupler during towing. All hardware must be torqued to 125 ft. lbs. minimum.
- 3) Do not exceed 8" maximum extension for any gooseneck coupler.

How to Measure Extension:

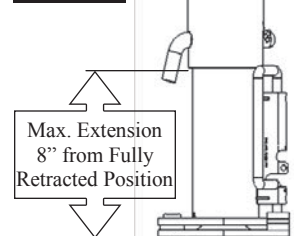

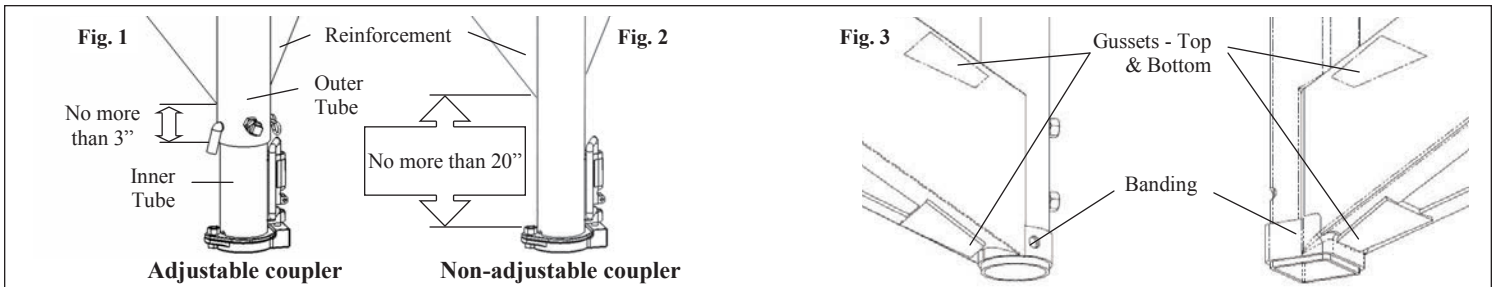

Gusseting:

To support the coupler's rated load, reinforcements must extend down the outer tube to within 3'' above the bottom of the outer tube (Fig. 1). The coupler must be held rigid and vertical, and must not be damaged by heat during installation. Note: Reinforcement for non-adjustable couplers must be within 20 inches above locking plates (Fig. 2). To reduce stress concentrations in high load, high mileage or rough service applications, gussets & banding that tie trailer framing to the coupler are **required** (Fig. 3). This modification is the responsibility of the trailer manufacturer.

Operation

To Couple:

- 1) Block trailer wheels.
- 2) Align hitch ball beneath coupler.
- 3) Set the locking pin in the open position.
- 4) Slide the locking plate into the open position and lower the trailer onto the hitch ball.
- 5) Visually check that the hitch ball is fully seated in the coupler.
- 6) Slide the locking plate into the closed position.
- 7) Set the locking pin in the closed position to close the coupler.

To Uncouple:

- 1) Block trailer wheels.
- 2) Set the locking pin in the open position.
- 3) Slide the locking plate into the open position and raise the trailer from the hitch ball.

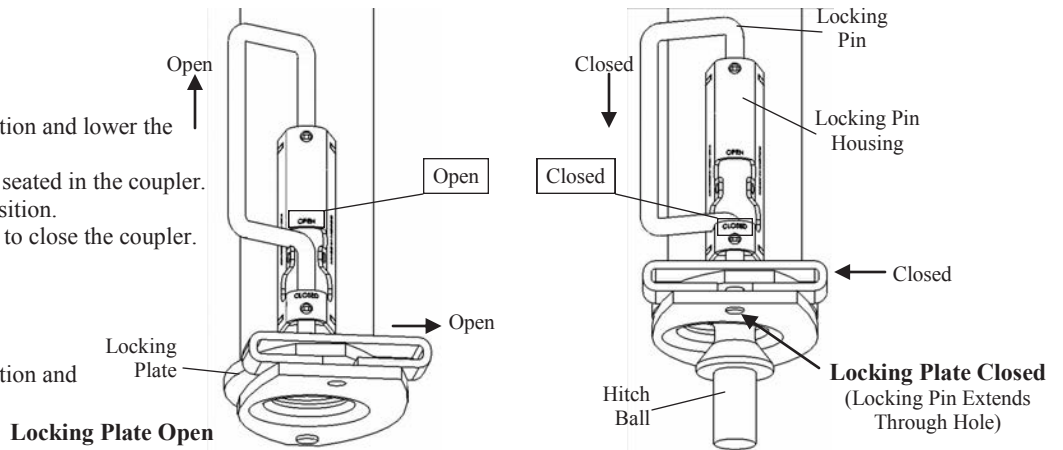

Maintenance

Keep ball pocket and mechanism clean. The following procedures should be performed at least annually:

- Check hardware torque
- Grease ball pocket
- Oil pivot points with SAE 30 wt. motor oil
- Inspect retaining pin and replace if necessary