

# Super Hoop Multi-Mount Step Installation Instructions

Part No's: 125771 / 125772 / 125574

## Vehicle Application:

### **DODGE**

'09-12 Ram 1500 All Cab / All Doors

'10-12 Ram 2500/3500 All Cabs / All Doors

### **MATERIAL NEEDED:**

Drill motor, 3/8" drill bit, 1/4" drill bit, 1/8" drill bit, pencil, Phillips screw driver, center punch, two 1/2" wrenches, two 7/16" wrenches, and silicone.

### **MATERIAL FURNISHED:**

Two castings, four zinc plated steel brackets, instruction page and two hardware packs (**Important! Not all of the parts in these hardware packs may be needed for proper installation.**)

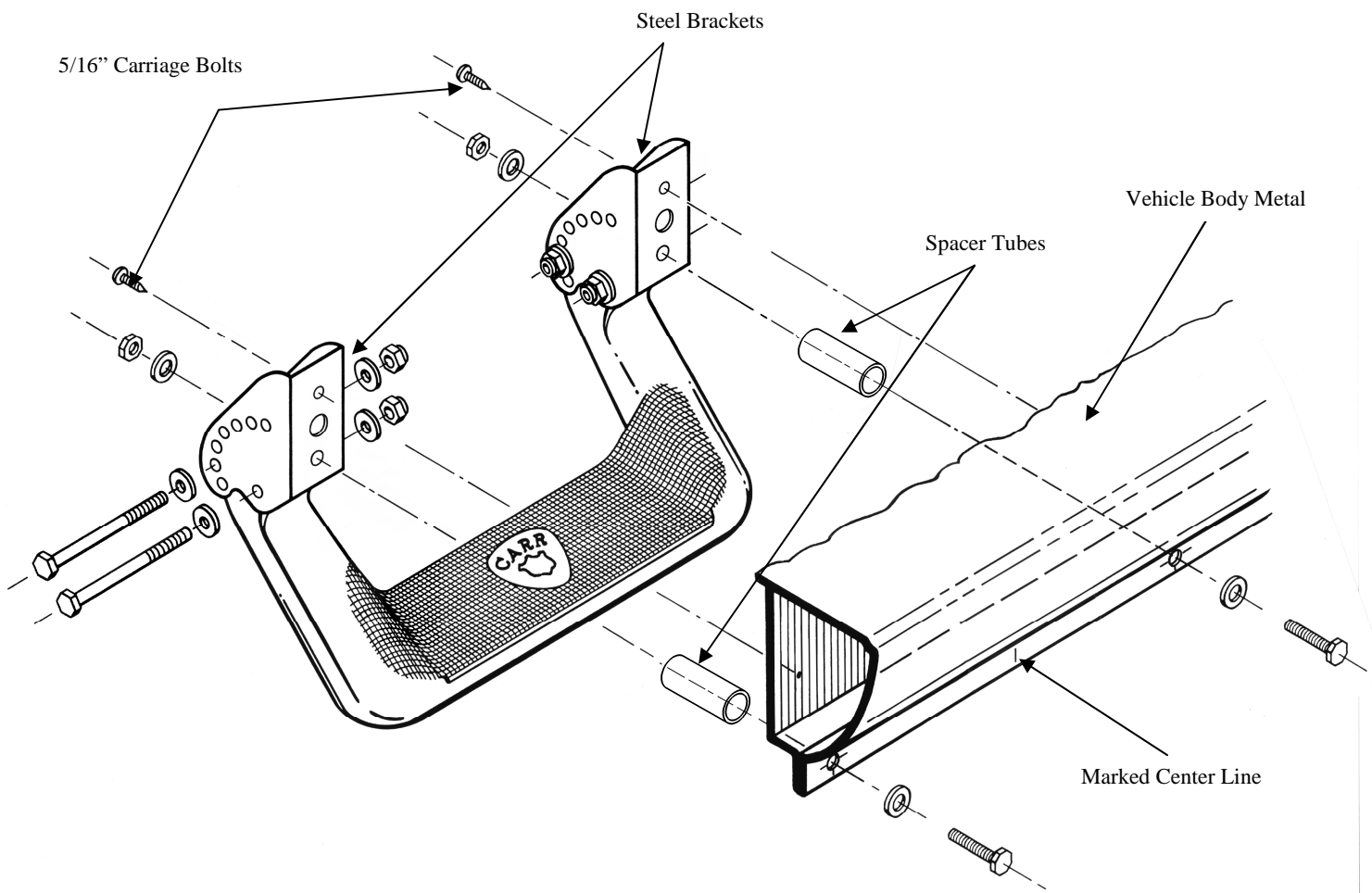



# Super Hoop Multi-Mount Step Installation Instructions

Part No's: 125771 / 125772 / 125774



## WARNINGS!

- ✓ Do not over tighten the nuts and bolts or damage to the castings and or stripping of the threads could result.
- ✓ FOR SAFE AND PROPER USAGE OF THIS PRODUCT, THE MOUNTING INSTRUCTIONS MUST BE FOLLOWED CAREFULLY AND COMPLETELY.
- ✓ The manufacturer and distributor of this product are in no way responsible for the consumer's failure to adhere to the warnings and directions of these instructions in the event of damage to the consumer's vehicle, other properties and or personal injury.
- ✓ **REFER TO DIAGRAM "A" WIRE HARNESS. STEP "12" ON THIS PAGE MUST BE FOLLOWED, IF NOT ELECTRICAL DAMAGE TO YOUR VEHICLE MAY OCCUR.**

1. Assemble the steel brackets to the step as shown in the drawing but only hand tighten.
2. For the proper position of the step, the front edge of the seat while in normal driving position should be in line with the center of the step. For personal preference or to avoid any obstruction underneath body metal, step can be moved left or right. When positioning the step against the body metal be sure to avoid all bumps and screws to make sure that the step is against a flat surface.
3. When you have found the position of where you want your step, mark the center on the pinch weld. See Marked Center Line on drawing.
4. On each side of the marked center line, mark two more lines 8 15/16" apart. Center punch the two outside lines in the middle (the vertical distance between the top of the pinch weld to the bottom edge of the pinch weld)
5. Take a 1/8" drill bit and drill out the centered punched holes.
6. Replace the 1/8" drill bit and drill out the 1/8" hole with a 5/16" drill bit. (Warning: when drilling holes leave at least 1/8" of metal between the hole and the outside edge of the pinch weld. If the 5/16" flat washer does not fit on the outside pinch weld due to interference, do not use them).
7. After drilling make sure that all the burrs are removed.
8. Place the step assembly back on the vehicle where the two holes were drilled. Be sure to install the space tubes.
9. Use the 5/16" x 2 1/2" bolts with the 5/16" hex nuts and 5/16" washers to securely tighten the brackets on the vehicle.
10. Using the top 1/4" hole at the top of each bracket, take a 1/8" drill bit and drill holes into the body metal. Take the 5/8" sheet metal screws provided and securely tighten. (Drilling at an angle may be necessary due to interference or for proper alignment).
11. If your step is not level, you can select a different hole on each steel bracket that will move the step up or down depending on the direction you need.
12. Check again and securely tighten ALL hardware.
13. We advise putting silicone sealer around the top 1/8" drilled holes
14. After one month of use, go back and give all hardware a final tightening.