

ROTA LIGHT BAR MOUNTING INSTRUCTIONS

Part No's: 210871, 210872 & 210874

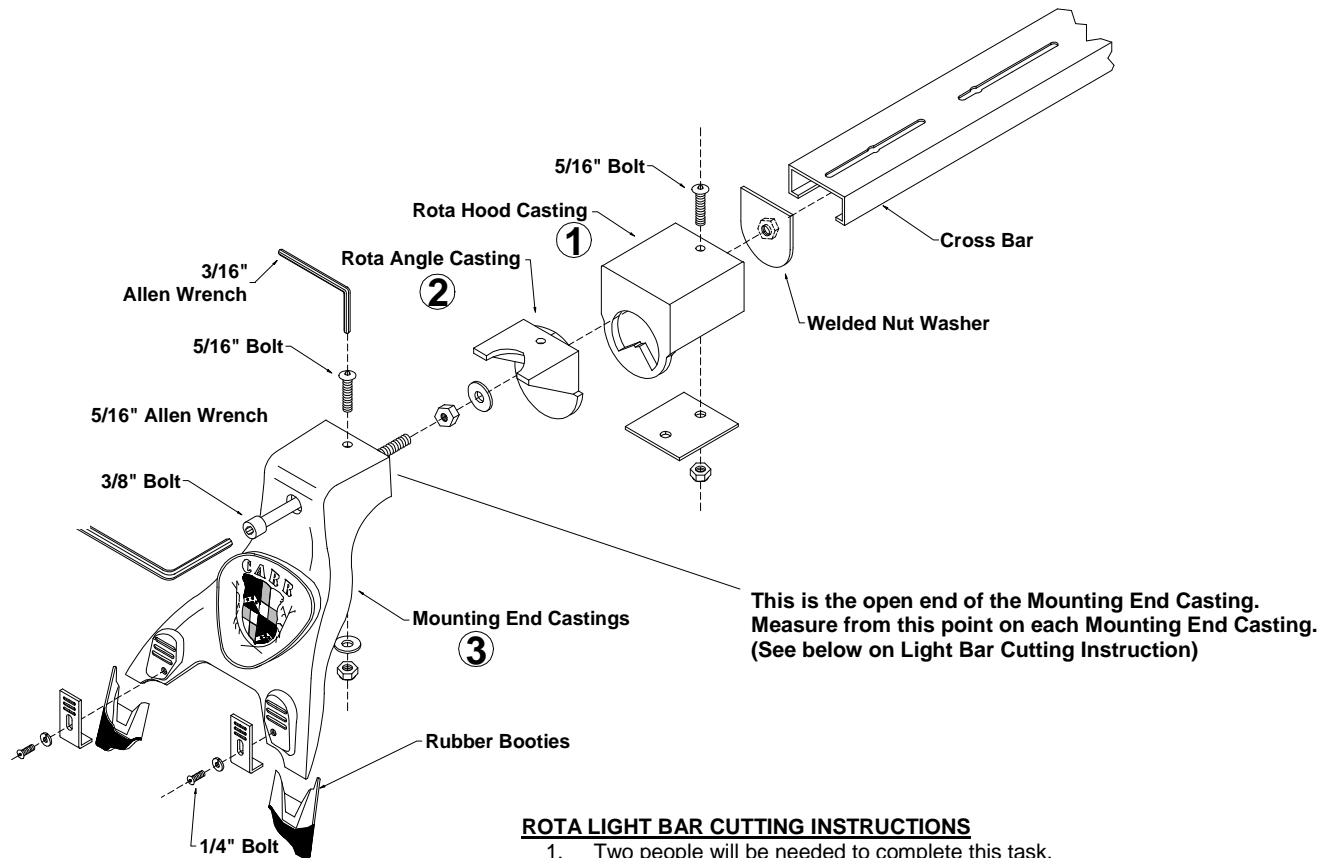

This is the open end of the Mounting End Casting. Measure from this point on each Mounting End Casting. (See below on Light Bar Cutting Instruction)

ROTA LIGHT BAR CUTTING INSTRUCTIONS

1. Two people will be needed to complete this task.
2. Place ONLY THE MOUNTING END CASTING into the rain-gutters of your vehicle.
3. Level each Mounting End Casting so that the top flat area is parallel to the horizon.
4. Take a tape measure and measure the distance between each open end of each Mounting End Casting.
5. From that dimension subtract 2 inches.
6. Subtract that total from the total length of the bar, which is 56".
7. Take the difference and divide it by two.
8. The amount divided by two is the amount you will cut off each end of your bar.
9. Measure and mark a line on both ends of the steel bar using the above dimension you have just figured.
10. Clamp one end of a bar into a vise. (Be careful not to scar the light bar).
11. Using a hacksaw, cut carefully along the marked lines. (If a vise is not available, put the bar on a table, secure tightly and cut).
12. Repeat steps 9-11 for the other end of the bar.

MATERIALS NEEDED: Hammer, center punch, pencil
MATERIALS FURNISHED: One hardware pack, two end castings, four Rota castings, cross bar, instruction page.

SPECIAL NOTE: VEHICLES NOT HAVING RAIN GUTTERS WILL REQUIRE RAIN GUTTER KITS:

- #220042** 76-93 Chevy S-10/Sonoma P/U, Blazer/Jimmy, '09-12 Dodge FS 1500 P/U All Cabs, 04-08 F-150 N.Body, 84-02 Isuzu Trooper, 97-02 Mitsub. Mont.Sport, 05-12 Toyota Prerunner Cr.Cab, 07-12 Tundra, 05-07 4-Runner, 07-12 FJ Cruiser
- #220052** 04-12 Chevy Colorado/GMC Canyon, 97-04 Dodge Dakota, 99-12 Ford Super Duty All Cabs, 00-05 Ford Excursion, 91-02 Isuzu Rodeo/Amigo, 05-12 Jeep Grand Cherokee, 83-93 Mazda B-Series P/U, 98-12 Nissan Frontier Reg.Cab, 02-12 Nissan Frontier Crew Cab, 00-12 Nissan Xterra-w/o Option Roof Rack, 86-01 Pathfinder, 86-97 Nissan Hard Body P/U, 89-95 Toyota P/U, 93-99 T-100, 84-04 Toyota 4-Runner, 96-04 Toyota Tacoma/Prerunner Crew Cab, 00-06 Toyota Tundra, 01-07 Toyota Sequoia.
- #220062** 04-12 F-150
- #220542** 00-12 Chevy/GMC Sierra/Silverado C/K P/U/FS, 02-09 Chevy Trail Blazer/Envoy, 02-12/Avalanche/GMC/Denali Truck, 00-12 Chevy Tahoe/Suburban/Tahoe/GMC Yukon/Yukon XL, 02-08 Dodge FS 1500 P/U, 03-10 Dodge 2500/3500 P/U & Quad, 02-08 Dodge Quad 1500, 05-09 Dodge Durango/Dakota, 06-12 Dodge Mega Cab 1500/2500/3500 Ram P/U
- #221502** 98-01 Dodge Quad Cab 1500 P/U, 98-02 Dodge Quad Cab 2500/3500 P/U, 94-02 Dodge 2500/3500 P/U Old Body Style, 94-01 Dodge P/U.
- #222742** 91-01 Ford Explorer(not Eddie Bauer)/Mercury Mountineer, 91-94 Mazda Navajo,
- #223412** 88-99 Sierra Silverado C&K P/U/FS, 92-99 Chevy Suburban/Yukon/Tahoe, 93-98 Jeep Grand Cherokee

ROTA LIGHT BAR MOUNTING INSTRUCTIONS

Part No's: 210871, 210872 & 210874

WARNINGS!

- ✓ Do not over tighten the nuts and bolts or damage to the castings and or stripping of the threads could result.
- ✓ FOR SAFE AND PROPER USAGE OF THIS PRODUCT, THE MOUNTING INSTRUCTIONS MUST BE FOLLOWED CAREFULLY AND COMPLETELY.
- ✓ The manufacturer and distributor of this product are in no way responsible for the consumer's failure to adhere to the warnings and directions of these instructions in the event of damage to the consumer's vehicle, other properties and or personal injury.
- ✓ DO NOT REMOVE the PVC tape from the light bar until cutting is completed. When cutting black bar leave plastic bag on and wrap a rag around bar before putting into a vise so no scratching of paint will result. Remove the PVC tape from the brackets (does not apply to black brackets). The light bar will not tighten properly unless the bar is straight across the cab.

1. **IMPORTANT: Cut the crossbar FIRST before proceeding to the next step! Refer to the Rota Light Bar Cutting Instructions on the other side.**
2. Place the black plastic booties on the feet of each casting.
3. Take the long 3/8" socket bolt and screw on to it the 3/8" jam nut all the way to the end of the threads and tighten down.
4. Place the head of the long socket bolt through the large hole in casting (3).
5. Leave the head of the long socket bolt extending all the way out of casting (3).
6. Place casting (2) inside of casting (3) and line up the two 5/16" holes.
7. Take the 5/16" Allen head screw and put it through both castings (3) and (2). Use the 5/16" washer and 5/16" nylon lock nut to securely tighten castings together.
8. **NOTE: THE FRONT FACE OF CASTING (2) SHOULD BE STRAIGHT ACROSS THE FACE OF CASTING (3).** When the castings are securely tightened together, casting (2) should be protruding approximately 1/16" beyond casting (3).
9. Place a 3/8" flat washer on the long 3/8" socket bolt and now put the long socket bolt through the other hole in casting (2).
10. Place casting (1) on casting (2).
11. With the welded nut washer facing away from casting (2) place it all the way to the inside of casting (1).
12. Screw the long 3/8" socket bolt into the washer with the welded nut all the way, and lightly tighten. **NOTE:** Use the 5/16" Allen wrench through the large hole in casting (3) to tighten and loosen the rotating motion.
13. Repeat steps 1 through 11 for the other side.
14. With the holes in the bar, in the up position, take casting (1) and by squeezing the end of the bar, place casting (1) on the bar, until the inside top wall of the casting is flat against the bar.
15. Take a 5/16" Allen head screw and put it through the hole in casting (1), and the slot in the bar, with the head of the screw in the up position. **IMPORTANT:** For some trucks when the bar is cut and put into casting (1), there may not be a slot left in the bar. If this is true, follow the next ten steps.
 - a. With the black booties on the back of casting (3), place the entire casting assembly into the rain gutter of the vehicle.
 - b. Position the foot of the "L" shaped steel brackets underneath the rain gutter and line up the vertical slot of the bracket with the tapped hole in the casting. Insert (2) 1/2" tamper proof Allen head bolts with lock washers through the "L" bracket securing the bracket to the support casting. **DO NOT TIGHTEN**
 - c. Place a screwdriver through the desired horizontal slot in the steel bracket, at the same time put the screwdriver into one of the three slots provided in the casting. **(Proper selection of the slots in the bracket and the slots in the casting will result in a tighter fit on the vehicle).**
 - d. Push the screwdriver against the casting and pry up against each bracket, one at a time, until both the casting and brackets are tightly secured in place. Tighten the two Allen head bolts. **CAUTION:** Prying up excessively could result in bending of the bracket or stripping the slots in the castings.
 - e. Follow the same procedure in steps a, b, c, and d, to secure the other casting to rain gutter.
 - f. By squeezing the ends of the bar put the bar back inside of casting (1).
 - g. With bar in castings, take a pencil and using the hole on top of casting (1), mark a circle on each end of the bar.
 - h. Take the bar out and drill a 3/8" hole through each marked circle. Deburring may be necessary.
 - i. Put the bar back into castings and use the other 5/16" Allen head screws and put them through the top holes in casting (1) and through the holes drilled in the bar. Take the two large flat washers and the 5/16-18 nylon lock nuts, as shown in diagram, and securely tighten bar to casting (1). **NOTE:** Be sure that the large washer is completely underneath casting (1).
 - j. Refer to step 15 for further instructions.
16. Take the larger washer and put it inside the bar, with the 5/16" Allen head screw, going through the washer. **IMPORTANT:** Be sure that the large washer is completely underneath casting.
17. With the larger washer in position, take a nylon lock nut and Allen wrench provided, and lightly tighten the bar to casting.
18. Follow the same procedure in steps 15, and 16 to attach other casting to the bar.
19. With both of the castings lightly tightened to the bar, take the entire bar and place the bar, with the castings, into the rain gutter of your vehicle.
20. Loosen, **DO NOT REMOVE** hardware on bar and casting.
21. Slide castings in or out on bar, so that each casting sets completely in rain gutters. **IMPORTANT:** Make sure that the bar is centered and that the bar is evenly divided into each casting and that each casting is directly across from each other.
22. Once again, take Allen wrench and tighten securely the bar to each casting.
23. Position the foot of the "L" shaped steel brackets underneath the rain gutter and line up the vertical slot of the bracket with tapped hole in the casting. Insert (2) 1/2" Tamper proof Allen head bolts with lock washers through the "L" bracket securing the bracket to support casting. **DO NOT TIGHTEN! (Proper selection of the slots in the bracket and the slots in the casting will result in a tighter fit on the vehicle).**
24. Place a screwdriver through the desired horizontal slot in the steel bracket, at the same time put the screwdriver into one of three slots provided in the casting. **(Proper selection of the slots in the bracket and the slots in the casting will result in a tighter fit on the vehicle).**
25. Push the screwdriver against the casting and pry up against each bracket, one at a time, until both the casting and brackets are tightly secured in place. Tighten the two Allen head bolts. **CAUTION:** Prying up excessively could result in bending of the bracket or stripping the slots in the castings.
26. Follow the same procedure in steps 22, 23, and 24 to secure other casting to rain gutter.
27. The bar and casting should now be tightly secured to the vehicle.
28. **CAUTION: WHEN LIGHTS ARE INSTALLED ON YOUR BAR AND YOU WANT TO LOOSEN YOUR BAR TO ROTATE THE BAR DOWN, BE CAREFUL NOT TO LOOSEN TOO MUCH BECAUSE LIGHTS COULD CRASH INTO THE CAB OF THE TRUCK AND CAUSE DAMAGE TO THE TRUCK AND LIGHTS, AND DO NOT LOSE YOUR ALLEN WRENCH.**
29. Your light bar hardware may settle in. After 2 or 3 weeks of use, go back and re-tighten all hardware. A periodic check on all hardware is recommended.
30. To maintain the luster of your light bar, apply a polish on a regular basis.