

Work Truck Step Installation Instructions for Ford Transit Van Rear Door

Part No: 501079

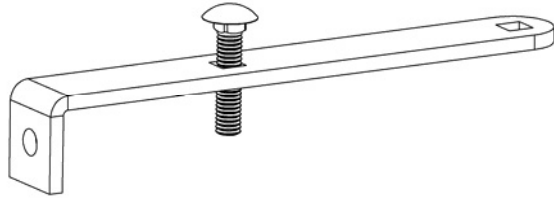

1. Take one of the Long "L" Brackets and insert one of the longer carriage bolts as shown.

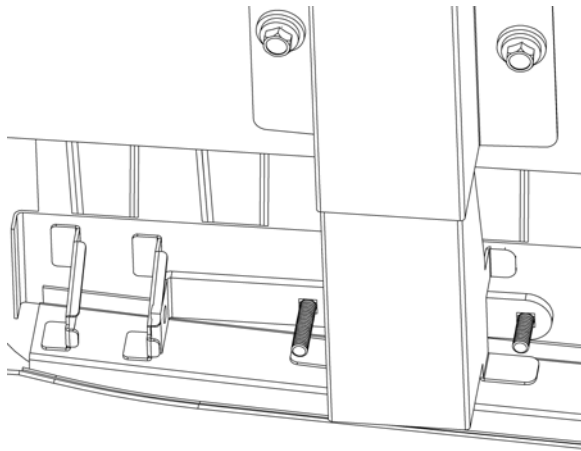

2. From underneath the rear bumper on the passenger side, slide the Long "L" Bracket up above the channel on the vehicle as shown. Insert one of the short carriage bolts on the end of the Long "L" Bracket.

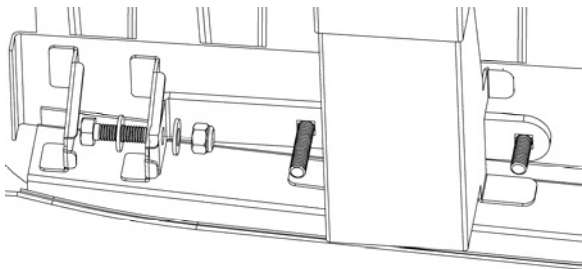

3. Take one of the hex head bolts with two washers and a nylon lock nut and hand-tighten this hardware to the vehicle and the Long "L" Bracket shown in the diagram.

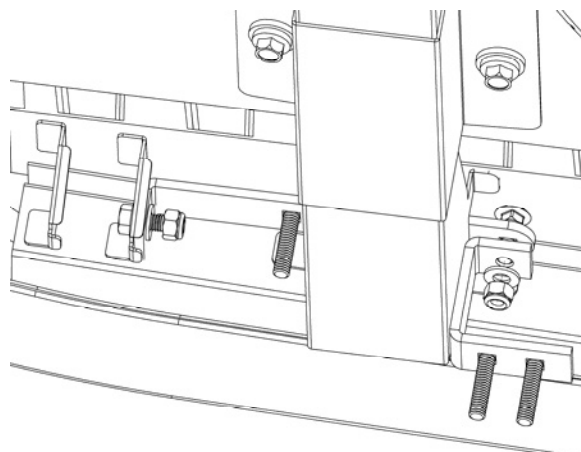

4. Take one of the "C" Brackets and slide it on to the shorter carriage bolt with a washer and nylon lock nut and only hand-tighten. Place two additional longer carriage bolts through the two holes at the bottom of the "C" Bracket. See diagram.

Work Truck Step Installation Instructions for Ford Transit Van Rear Door

Part No: 501079

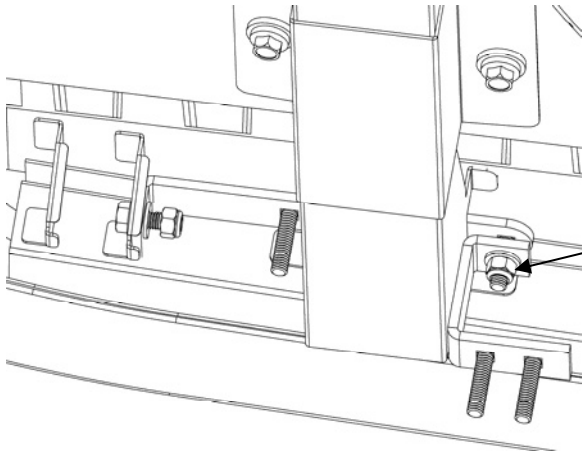

5. A very important step in the installation process, make sure to tighten this nylon lock nut so the bolt only comes through an 1/8". If this nylon lock nut gets over-tightened, it will be very difficult to install the front bolts later in step 10.

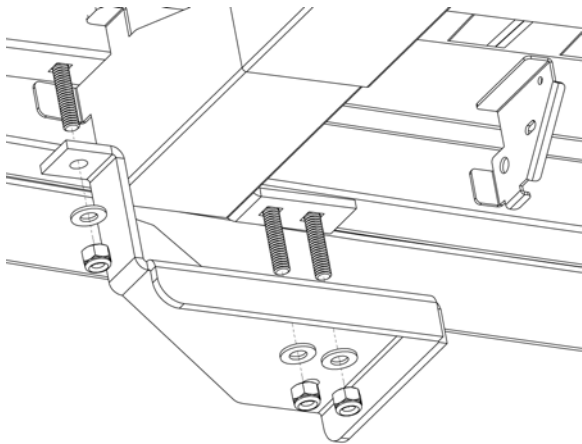

6. Take the right Main Bracket and slide it up with the three carriage bolts going through it. The rib on this Main Bracket goes between the plastic bumper and steel channel on the vehicle. It may be a tight fit.

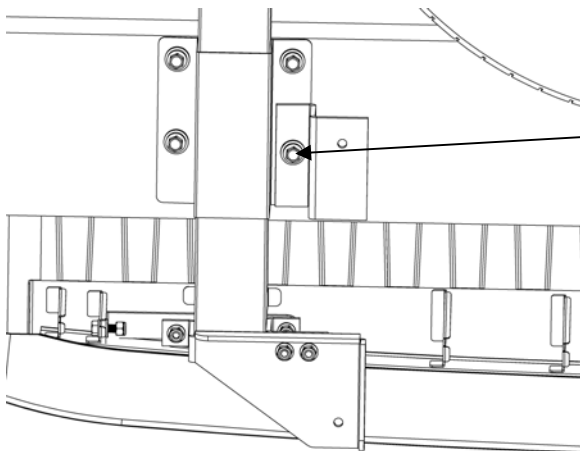

7. Remove the inside front bolt from the vehicle and place the right side Back Bracket in place. Reinstall the vehicle bolt and only hand-tighten. Follow these seven steps for the brackets on the driver's side, reversing the instructions when necessary.

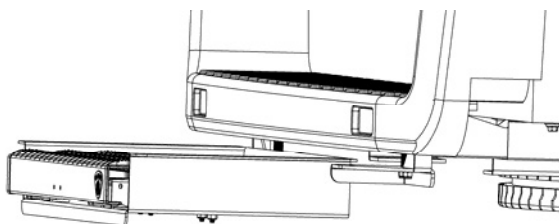

8. With all the brackets installed and hanging loose, take the entire step assembly and slide it on top of the brackets until the back of the pan hits the spare tire.

Work Truck Step Installation Instructions for Ford Transit Van Rear Door

Part No: 501079

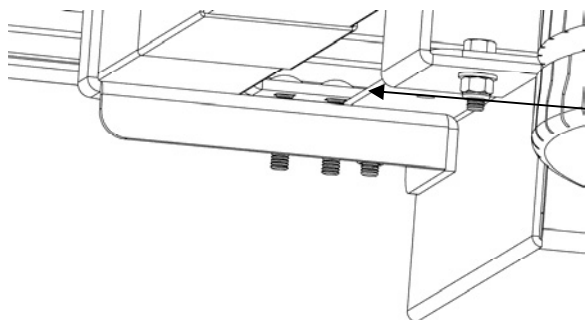

9. Make sure the feet of the "C" Brackets from Step 4, on both sides, are on top of the flange of the black powder coated pan.

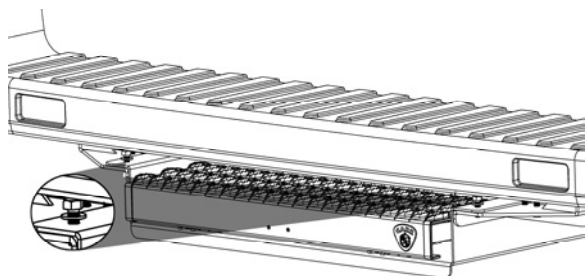

10. Take two 5/16" hex bolts with washers and insert them in the front holes of the Main Brackets so they go through the pan. The first bolt and washer will be fairly easy to install. The second one may be more difficult. Wiggle the entire assembly if the fit is tight until the bolt and washer are installed. Take two washers and two nylon lock nuts and hand-tighten to these bolts.

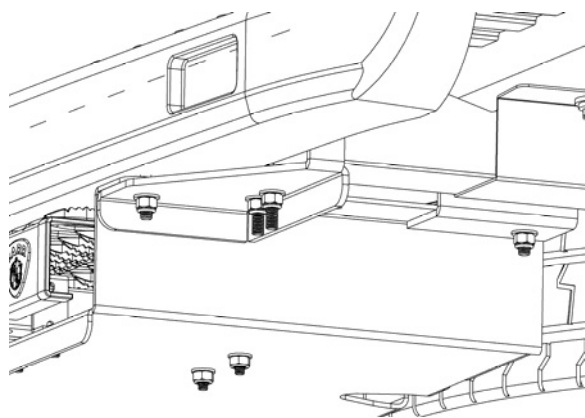

11. Once all the hardware has been installed, securely tighten the step assembly to your vehicle. Push on the step to deploy it. Then push it in to lock it in place.

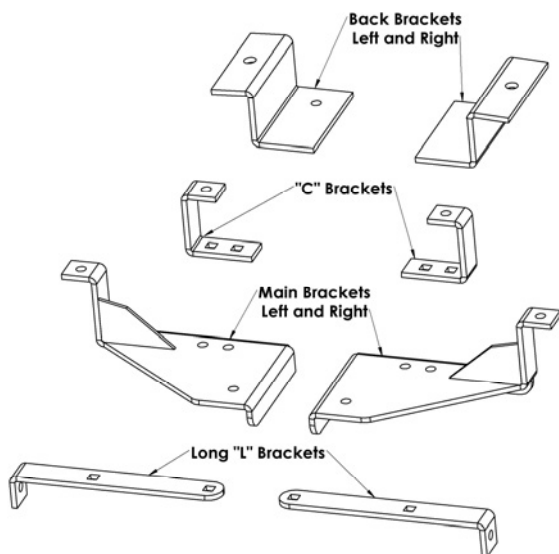

12. Lubricate your step on a regular basis to maintain easy operation. Spray this lubrication (see right image) or similar product on the inner rails of your step. It is best to use a silicone spray that dries without wet residue.

