



Super Hoop Step Installation Instructions

Part No's: 129111 / 129112 / 129114 / 129117



WARNINGS!

- ✓ Do not over tighten the nuts and bolts or damage to the castings and or stripping of the threads could result.
- ✓ FOR SAFE AND PROPER USAGE OF THIS PRODUCT, THE MOUNTING INSTRUCTIONS MUST BE FOLLOWED CAREFULLY AND COMPLETELY.
- ✓ The manufacturer and distributor of this product are in no way responsible for the consumer's failure to adhere to the warnings and directions of these instructions in the event of damage to the consumer's vehicle, other properties and or personal injury.

Vehicle Application:

RAM

'19-'20 1500 All Cabs/All doors

NEW BODY STYLE

**WAX YOUR STEP ON A
REGULAR BASIS TO
MAINTAIN ITS LUSTER**

MATERIAL NEEDED:

Variable speed Drill Motor, cutting oil, 5/16" drill bit (**solid carbide**), 3/16" drill bit (**solid carbide**), 2 - 1/2" wrench/socket, 2 - 7/16" wrench/socket, center punch, hammer, marker or pencil, flat blade screw driver or 5/16" socket.

MATERIAL FURNISHED:

Two step castings, four mounting brackets, instruction page and two hardware packs. (**Not all hardware may be used**)

1. Using the 1/4" hardware provided, assemble the steel mounting brackets to each step casting as indicated in this drawing. Securely tighten all hardware. **DO NOT** use flat washers!

ALL DRAWINGS ARE VIEWED FROM THE DRIVERS SIDE

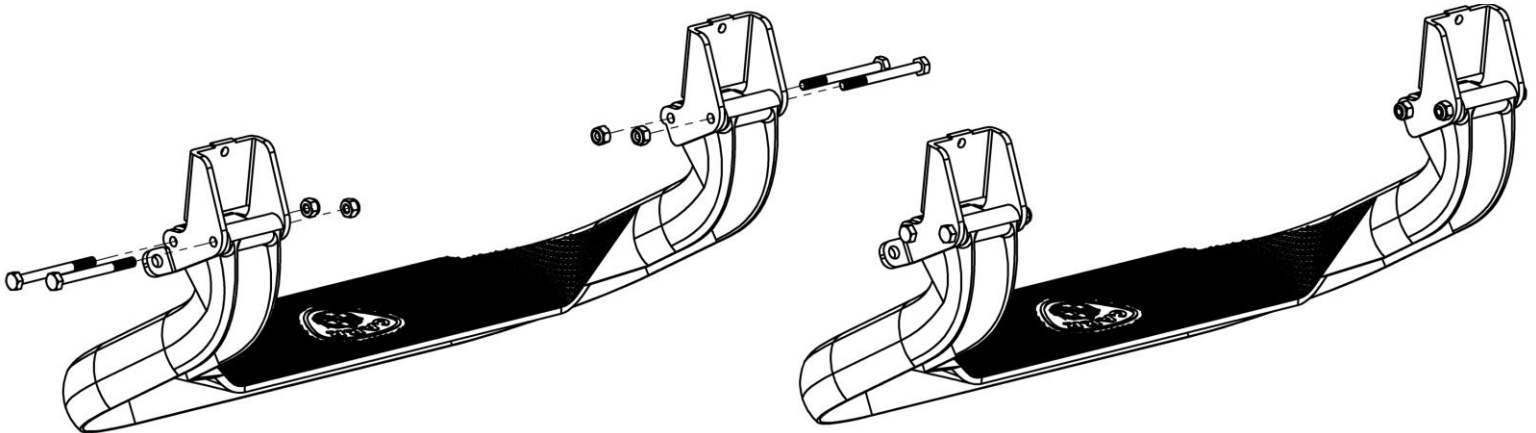



Super Hoop Step Installation Instructions

Part No's: 129111 / 129112 / 129114 / 129117

RAM '19-'20 1500 All Cabs/All Doors

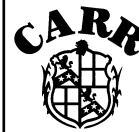

ALL DRAWINGS ARE VIEWED FROM THE DRIVERS SIDE

- Place each step in the position indicated in each drawing. Move the front door step so that the front steel mounting bracket is up against the three-bolt cluster. Move the rear door step against the other three-bolt cluster. Mark the bottom edge of the pinch weld where each hole center will be drilled. Transfer those marks on the body metal referred to in the next step.

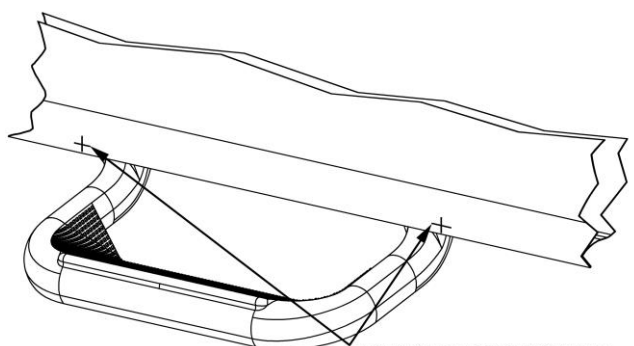
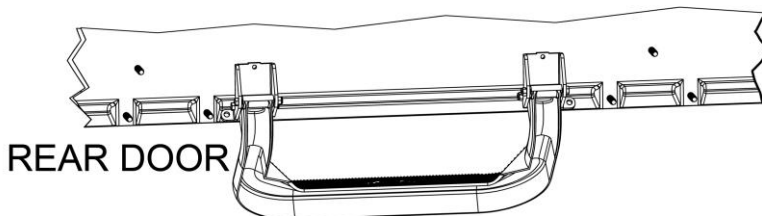
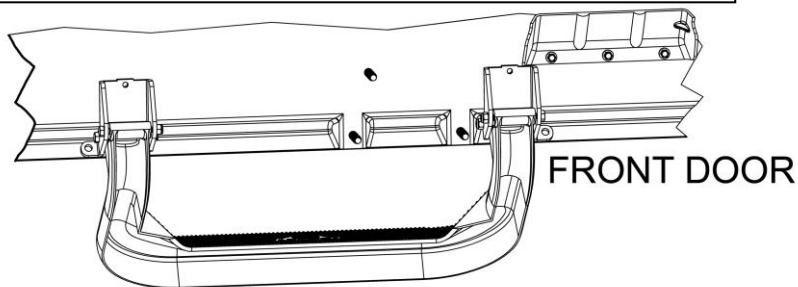

MARKED HORIZONTAL LINES 1/2" UP FROM BOTTOM OF PINCH WELD

- Transfer the marks from the previous step and mark the front and rear step on the outside body metal as indicated on this drawing. Center punch marked lines. With the variable drill motor, using plenty of cutting oil, take a 3/16" **solid carbide** drill bit and drill out at a slow speed the centered punched holes. Again, using plenty of cutting oil and at a slow speed, drill out the 3/16" hole with the 5/16" **solid carbide** drill bit.

- Take the 5/16" hardware provided and securely mount the step assembly to the body of the vehicle. Do not use any flat washer under the 5/16" nylon nuts. Using the top 1/4" holes in each steel mounting bracket as a guide, drill out each hole with a 3/16" drill bit. Install the four sheet metals screws as indicated using the flat blade screwdriver or the 5/16 socket. Now your steps are ready to go! Repeat the same steps for the passenger side.

