

No-Drill Super Hoop Step Mounting Instructions

Part No's: 125001 / 125002 / 125004 / 125007



Vehicle Application:

FORD

'99-'16 Super Duty all cabs/all doors/all series

MATERIAL NEEDED:

Two 7/16" wrenches, two 1/2" wrenches.

MATERIAL FURNISHED:

Two step castings, four zinc plated steel brackets, one hardware pack and an instruction sheet.

Exploded View of Clip Installation

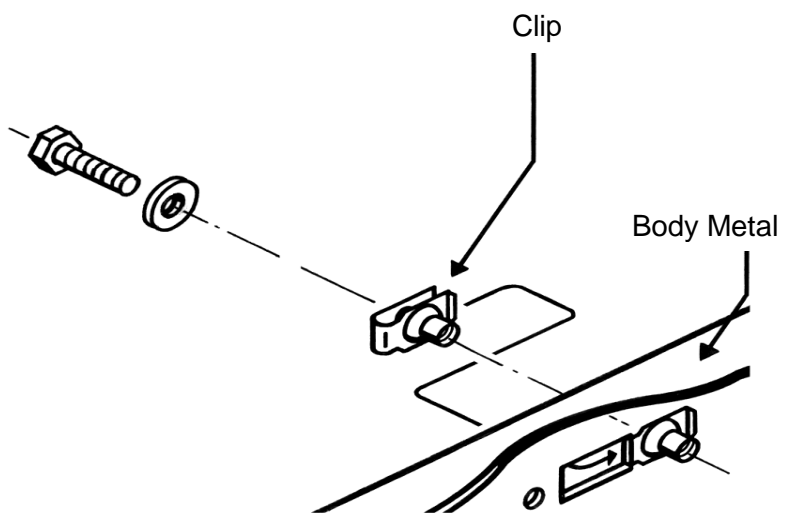

WARNINGS!

- ✓ Do not over tighten the nuts and bolts or damage to the castings and or stripping of the threads could result.
- ✓ FOR SAFE AND PROPER USAGE OF THIS PRODUCT, THE MOUNTING INSTRUCTIONS MUST BE FOLLOWED CAREFULLY AND COMPLETELY.
- ✓ The manufacturer and distributor of this product are in no way responsible for the consumer's failure to adhere to the warnings and directions of these instructions in the event of damage to the consumer's vehicle, other properties and or personal injury.
- ✓ REFER TO DIAGRAM "A" WIRE HARNESS. STEP "8" ON THIS PAGE MUST BE FOLLOWED, IF NOT ELECTRICAL DAMAGE TO YOUR VEHICLE MAY OCCUR.

**See the other side of this
Instruction for vehicles
installations**

**WAX YOUR STEP ON A
REGULAR BASIS TO
MAINTAIN ITS LUSTER**



Super Hoop Multi-Mount Step Installation Instructions

Part No's: 125001 / 125002 / 125004 / 125007

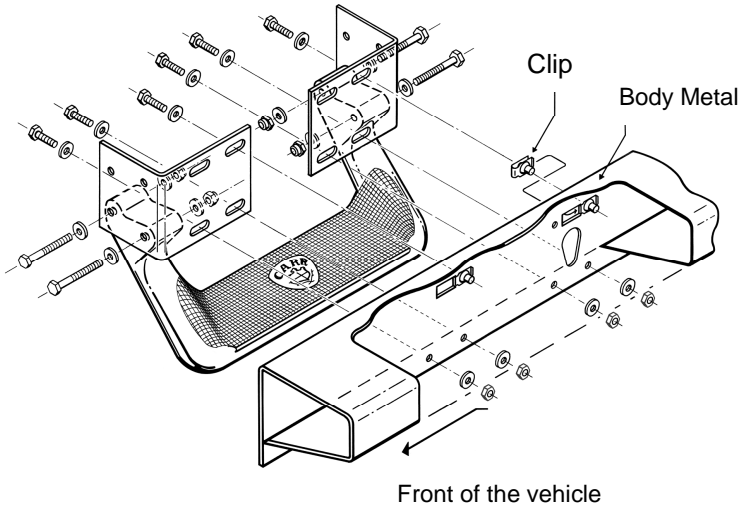

DIAGRAM FOR:
Front door ALL CABS.
Drivers side shown here

1. Place the steel brackets on the step casting the same way as shown on the diagram.
2. Securely tighten the steel brackets to the step casting with the 1/4" hardware provided.
3. Install the clips as shown here by pushing the clips to the side. (A larger view of the clips installation is available on the reverse side of this sheet).
4. Take the 5/16" hardware that is provided and bolt the step and bracket assembly to the truck under the front door using the holes in the truck as indicated on the diagram.
5. Repeat the same procedure for the passenger side of your vehicle.

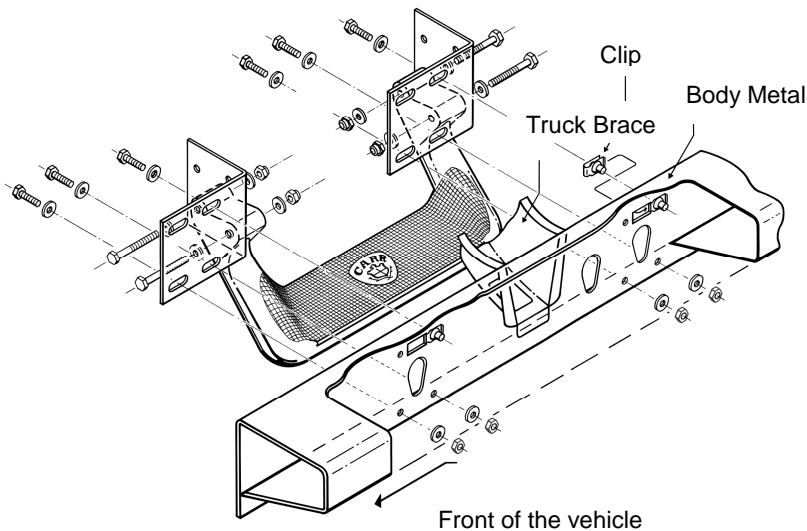

DIAGRAM FOR:
Rear door EXTENDED CAB.
Drivers side shown here

1. Place the steel brackets on the step casting the same way as shown on the diagram.
2. Securely tighten the steel brackets to the step casting with the 1/4" hardware provided.
3. Install the clips as shown here by pushing the clips to the side. (A larger view of the clips installation is available on the reverse side of this sheet).
4. Take the 5/16" hardware that is provided and bolt the step and bracket assembly to the truck under the rear door using the holes in the truck as indicated on the diagram.
5. Repeat the same procedure for the passenger side of your vehicle only reverse how the steel brackets bolt to the step casting.

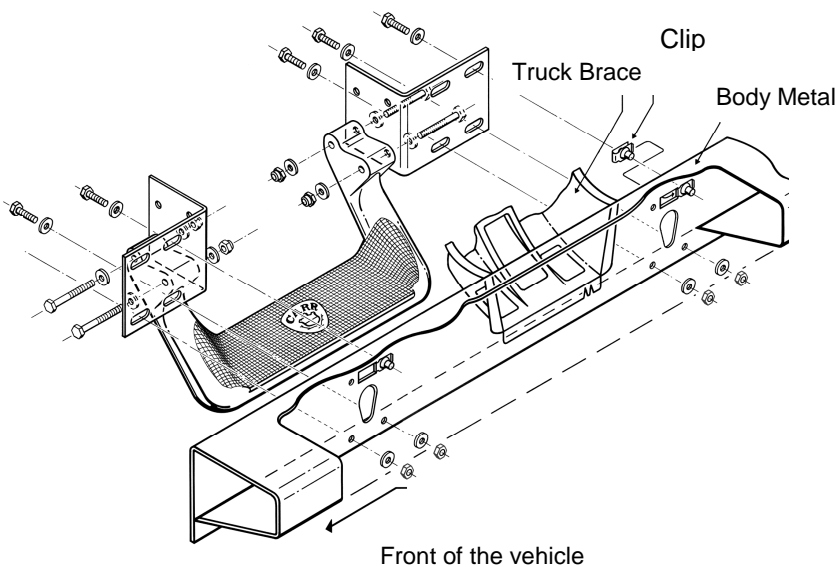

DIAGRAM FOR:
Rear door CREW CAB.
Drivers side shown here

1. Place the steel brackets on the step casting the same way as shown on the diagram.
2. Securely tighten the steel brackets to the step casting with the 1/4" hardware provided.
3. Install the clips as shown here by pushing the clips to the side.. (A larger view of the clips installation is available on the reverse side of this sheet).
4. Take the 5/16" hardware that is provided and bolt the step and bracket assembly to the truck under the rear door using the holes in the truck as indicated on the diagram.
5. Repeat the same procedure for the passenger side of your vehicle only reverse how the steel brackets bolt to the step casting.