



Quality and Style that Endures

Vehicle Application:

Dodge

'09-'17 Ram 1500-3500 All Cabs/All Doors/**PICKUP BEDS ONLY**/Diesel and Gas

'09-'17 Ram 1500-5500 All Cabs/All Doors/**ALL BEDS**/Gas only

WAX YOUR STEP ON A REGULAR BASIS TO MAINTAIN ITS LUSTER

MATERIAL NEEDED:

Drill Motor, 5/16" drill bit, 1/8" drill bit, 2 - 1/2" wrench/socket, 2 - 7/16" wrench/socket, center punch, hammer, marker or pencil.

MATERIAL FURNISHED:

2 - LD Step Castings, 4 - Mounting Brackets, 1 - Hardware pack, 1 - Instruction sheet.

Diagram A

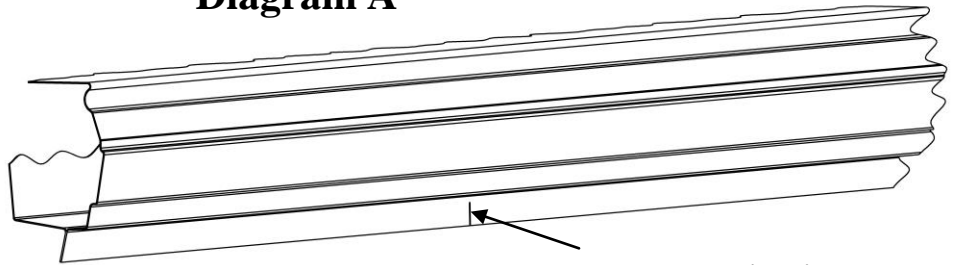

Marked vertical line on the outside painted pinch weld that lines up with the front edge of the seat.

Diagram B

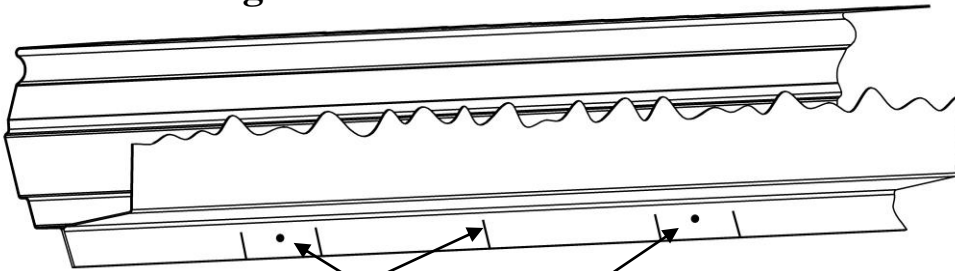

Marked vertical line that was transferred from Diagram A to the inside of the rocker panel.

Marked lines from edges of Mounting Brackets with marked holes from the same Mounting Brackets.

Diagram C

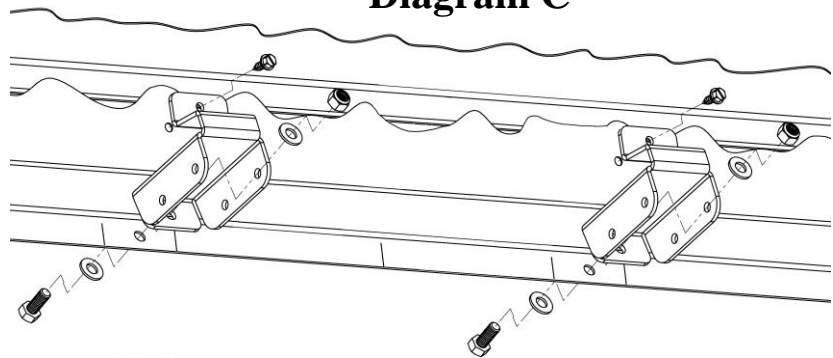
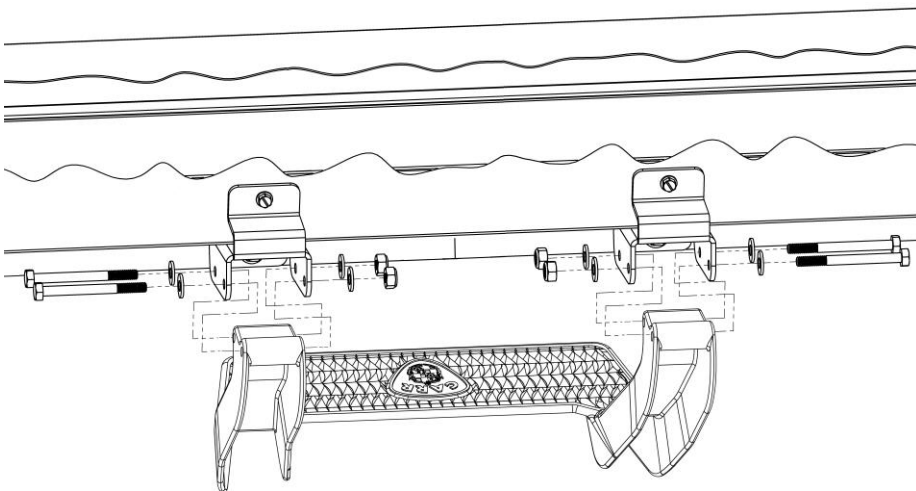

Diagram D





LD Step Installation Instructions

Part No's: 119771 / 119772 / 119774

Approximate installation time for one step – 30 minutes!



WARNING!

- ✓ Do not over tighten nuts and bolts as damage to the castings and/or stripping of the threads could result.
- ✓ FOR SAFE AND PROPER USAGE OF THIS PRODUCT, THE MOUNTING INSTRUCTIONS MUST BE FOLLOWED CAREFULLY AND COMPLETELY.
- ✓ The manufacturer and distributor of this product are in no way responsible for the consumer's failure to adhere to the warnings and directions of these instructions in the event of damage to the consumer's vehicle, other properties and/or personal injury.

1. For the proper position of the step, the front edge of the seat while in normal driving position should be in line with the center of the step. For personal preference or to avoid any obstruction underneath body metal, step can be moved left or right.
2. Take a marker or pencil and mark a vertical line that lines up with the front edge of the seat on the pinch weld area of your vehicle. See DIAGRAM A.
3. Assemble the Mounting Brackets to the Step Casting as shown in DIAGRAM D. Hand tighten the hardware only.
4. When positioning the step against the body metal, be sure to avoid all bumps and screws to make sure that the step assembly is against a flat surface.
5. With both Mounting Brackets hand-tightened on the Step Casting, place the entire assembly against the inside of the rocker panel of the vehicle. Line up the center of the step with the center vertical marked line. (Be sure to avoid any bumps or obstructions on body metal.)
6. While holding the entire assembly in place, take a pencil or marker and mark all four outside edges of the Mounting Brackets as shown in DIAGRAM B.
7. Remove the Mounting Brackets from the Step Casting.
8. Place the Mounting Brackets back against the body metal between the marked lines. Use the holes in the Mounting Brackets to mark the holes on the body metal as shown in DIAGRAM B.
9. Center punch the marked hole.
10. Take a 1/8" drill bit and drill out the centered punched holes.
11. Drill out the 1/8" hole with the 5/16" drill bit.
12. After drilling, make sure that all burrs are removed.
13. Take the 5/16" hardware that is provided and securely tighten both Mounting Brackets to the vehicle. See DIAGRAM C.
14. Place the Step Casting inside each Mounting Bracket and use the 1/4" hardware provided and securely tighten each Mounting Bracket to the Step Casting. See DIAGRAM D.
15. Take a 1/8" drill bit and drill two more holes through the top holes that are located on each Mounting Bracket. (NOTE: These holes may need to be drilled at an angle on the rear doors.)
16. Take the sheet metal screws provided and securely tighten. See DIAGRAM C.
17. Repeat these steps for all other doors. Your step is now ready to use!