

LD Step Installation Instructions

Part No's: 114871 / 114872 / 114874 / 114877



Vehicle Application:

FORD

'99-'16 Super Duty PU all Cabs/all doors/all series
'00-'05 Excursion all doors

MATERIAL NEEDED:

Drill motor, 3/8" drill bit, 1/8" drill bit, 1/4" drill bit, pencil, Phillips screw driver, center punch, two 1/2" wrenches, two 7/16" wrenches, and silicone.

MATERIAL FURNISHED:

Two LD Steps castings, four steel mounting brackets, instruction page and two hardware packs. **(Important! Not all of the parts in these hardware packs may be needed for proper installation).**

**WAX YOUR STEP ON A
REGULAR BASIS TO
MAINTAIN ITS LUSTER**

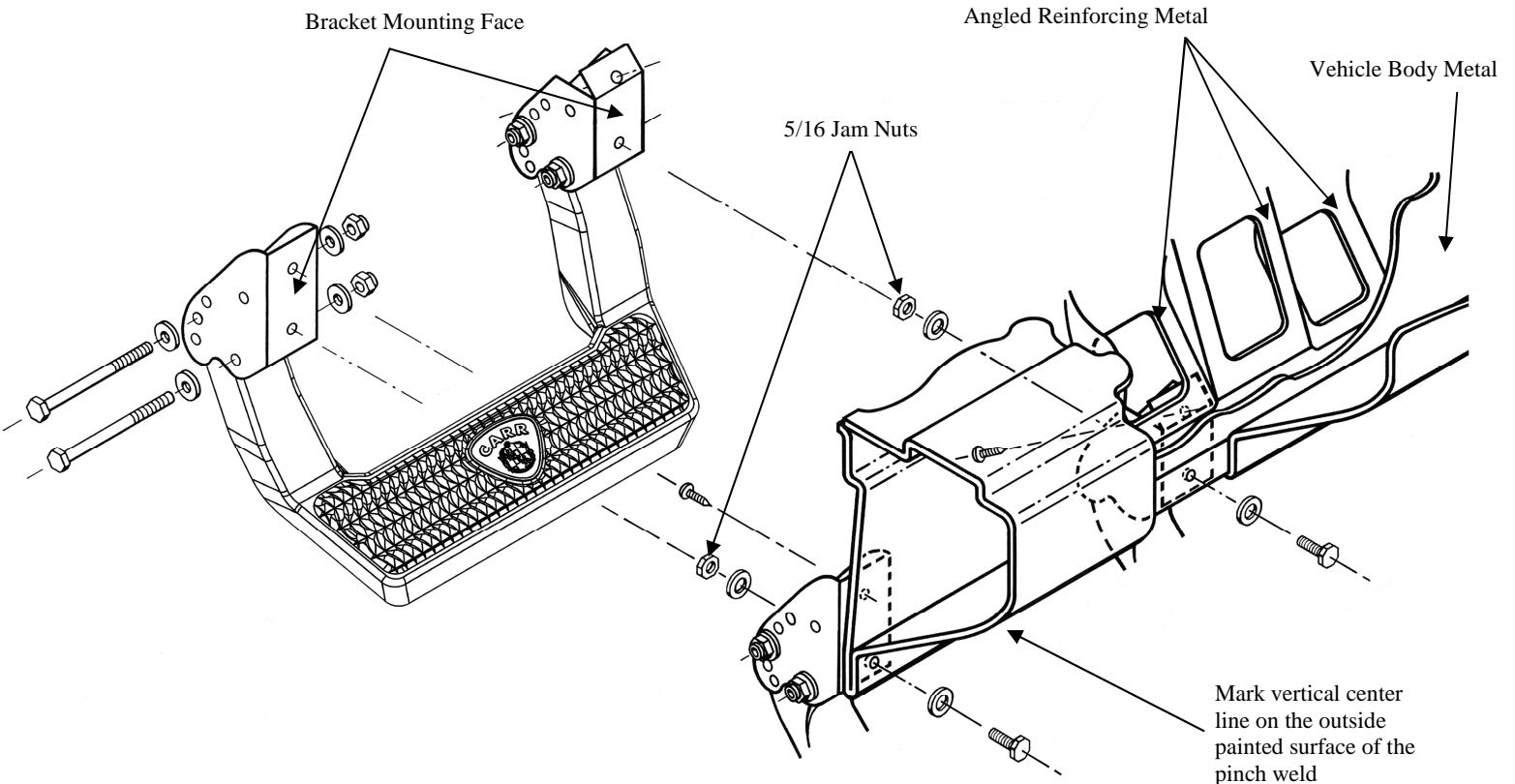



LD Step Installation Instructions

Part No's: 114871 / 114872 / 114874 / 114877



WARNINGS!

- ✓ Do not over tighten the nuts and bolts or damage to the castings and or stripping of the threads could result.
- ✓ FOR SAFE AND PROPER USAGE OF THIS PRODUCT, THE MOUNTING INSTRUCTIONS MUST BE FOLLOWED CAREFULLY AND COMPLETELY.
- ✓ The manufacturer and distributor of this product are in no way responsible for the consumer's failure to adhere to the warnings and directions of these instructions in the event of damage to the consumer's vehicle, other properties and or personal injury.

1. These steps mount to an extremely strong part of your vehicle, the back side of its rocker panels. For the proper position of the step, the front edge of the seat while in normal driving position should be in line with the center of the step. For personal preference or to avoid any obstruction that may be on the backside of the rocker panel, the step can be moved towards the front or the rear of the vehicle.
2. Assemble the steel mounting brackets to the step as shown in the diagram, but only hand tighten. **NOTE: Use the bracket with the double bends where the angled reinforcing metal is located on the vehicle.**
3. When positioning the assembled step against the back side of the rocker panel, be sure to avoid all bumps and screws to ensure that the step is against a flat surface. Take a pencil and mark a vertical line that lines up with the front edge of the seat, on the outside painted surface of the pinch weld. (See diagram). Disassemble the brackets from the step.
4. Measure 6 3/4" on each side of the marked vertical line and mark two more lines on that same surface. The dimension between the two outside marked lines should be 13 1/2".
5. Measure 3/8" from the edge of the pinch weld where you marked the other vertical lines and mark two horizontal lines, creating a cross hair. **NOTE: DOUBLE CHECK DIMENSIONS BEFORE DRILLING!** (Warning: when drilling holes leave at least 1/8" of metal between the hole and the edge of the pinch weld).
6. Take a center punch and punch the center where the two sets of lines cross.
7. Take a 1/8" drill bit and drill out the centered punched holes.
8. Enlarge the 1/8" hole with a 5/16" drill bit.
9. After drilling, make sure that all the burrs are removed.
10. Place the steel mounting brackets on the vehicle where the two holes are drilled.
11. Use the 5/16" x 5/8" hex bolts with the 5/16" hex nuts and 5/16" washers to securely tighten the brackets on the vehicle.
12. Using the top 1/4" hole at the top of each bracket, take a 1/8" drill bit and drill holes into the body metal. Take the 5/8" sheet metal screws provided and securely tighten. (Drilling at an angle may be necessary due to interference or for proper alignment). Place the step back into the brackets and securely tighten.
13. We advise putting silicone sealer around the areas where the aluminum mounting brackets contact the body metal.
14. After one month of use, go back and give all hardware a final tightening.