



Hoop II Step Installation Instructions

Part No's: 108221-1 / 108222-1 / 108224-1 / 108227-1

FRONT DOOR INSTRUCTIONS

Vehicle Application:

Ford

- '15- '20 F-150 Aluminum Body All Cabs/All Doors
- '17- '20 Super Duty Aluminum Body All Cabs/All Doors
- '17- '20 Does Not Fit F-550 Single Cab
- '18- '20 Expedition (All Doors)

WAX YOUR
STEP ON A
REGULAR
BASIS TO
MAINTAIN
ITS LUSTER

MATERIAL NEEDED:

Drill Motor, 5/16" drill bit, 1/8" drill bit, 2 - 1/2" wrench/socket, 2 - 7/16" wrench/socket, center punch, hammer, marker or pencil, matching exterior paint based on your vehicle paint code.

MATERIAL FURNISHED:

1 Hoop II Step Casting, 2 - Mounting Brackets, 1 - Hardware pack, 1 - Instruction sheet.

Diagram A

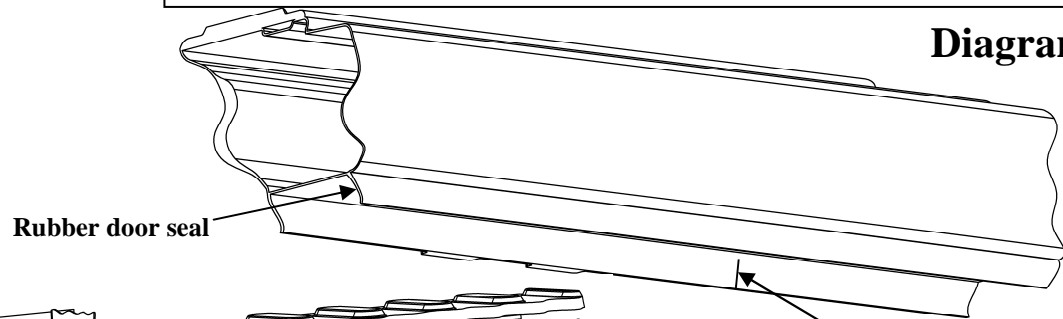
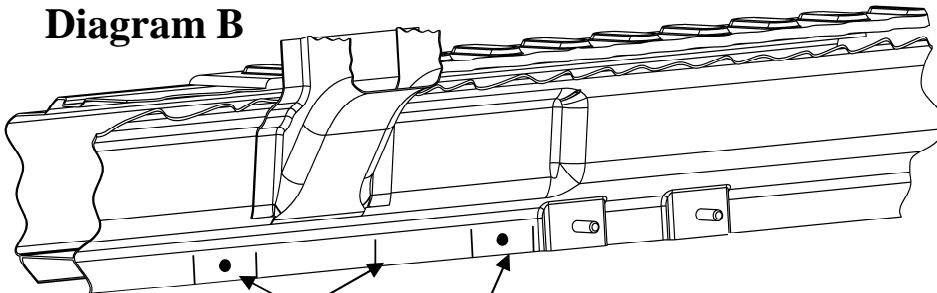

Diagram B



Marked vertical line that was transferred from Diagram A to the inside of the rocker panel.

Marked lines from edges of Mounting Brackets with marked holes from the same Mounting Brackets.

Diagram C

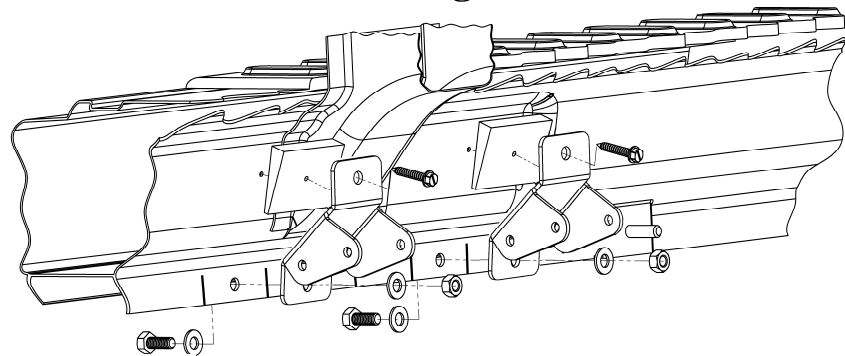
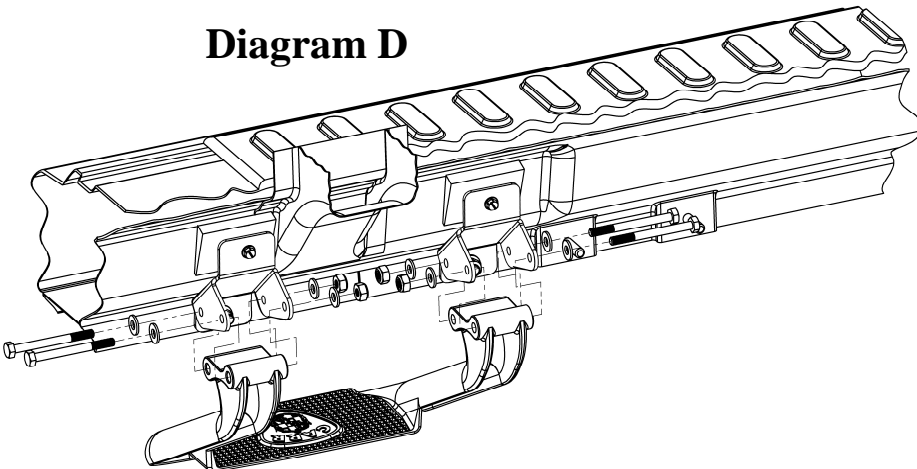

Diagram D





Hoop II Step Installation Instructions

Part No's: 108221-1 / 108222-1 / 108224-1 / 108227-1

FRONT DOOR INSTRUCTIONS

Approximate installation time for one step – 45 minutes!

WARNING!

- ✓ Do not over tighten nuts and bolts as damage to the castings and/or stripping of the threads could result.
- ✓ FOR SAFE AND PROPER USAGE OF THIS PRODUCT, THE MOUNTING INSTRUCTIONS MUST BE FOLLOWED CAREFULLY AND COMPLETELY.
- ✓ The manufacturer and distributor of this product are in no way responsible for the consumer's failure to adhere to the warnings and directions of these instructions in the event of damage to the consumer's vehicle, other properties and/or personal injury.

To find our YouTube channel type as one word into the YouTube search box:

CARRproducts

Then go to the Installation Videos section for your specific video

1. NOTE: All diagrams shown are viewed from the driver side front door. Open your front door. For the proper position of the step, the front edge of the seat while in normal driving position should be in line with the center of the step. For personal preference or to avoid any obstruction underneath body metal, step can be moved left or right.
2. Take a marker or pencil and mark a vertical line that lines up with the front edge of the seat on the pinch weld area of your vehicle. See DIAGRAM A.
3. Assemble the Mounting Brackets to the Step Casting as shown in DIAGRAM D. Hand tighten the hardware only.
4. When positioning the step against the body metal, be sure to avoid all bumps and screws to make sure that the step assembly is against a flat surface.
5. With both Mounting Brackets hand-tightened on the Step Casting, place the entire assembly against the inside of the rocker panel of the vehicle. Line up the center of the step with the center vertical marked line. (Be sure to avoid any bumps or obstructions on body metal.)
6. While holding the entire assembly in place, take a pencil or marker and mark all four outside edges of the Mounting Brackets as shown in DIAGRAM B.
7. Remove the Mounting Brackets from the Step Casting.
8. Place the Mounting Brackets back against the body metal between the marked lines. Use the holes in the Mounting Brackets to mark the holes on the body metal as shown in DIAGRAM B.
9. Center punch the marked hole.
10. Take a 1/8" drill bit and drill out the centered punched holes.
11. Drill out the 1/8" hole with the 5/16" drill bit.
12. After drilling, make sure that all burrs are removed.
13. Take your matching exterior paint and totally paint drilled holes to seal the aluminum metal. Allow paint to dry before proceeding to the next step.
14. Take the 5/16" hardware that is provided and securely tighten both Mounting Brackets to the vehicle. See DIAGRAM C.
15. Place the Step Casting inside each Mounting Bracket and use the 1/4" hardware provided and securely tighten each Mounting Bracket to the Step Casting. See DIAGRAM D.
16. Take a 1/8" drill bit and drill two more holes through the top holes that are located on each Mounting Bracket through the Wedge Washers into the body metal. (NOTE: These holes may need to be drilled at an angle on the rear doors.)
17. Take your matching exterior paint and totally paint drilled holes to seal the aluminum metal. Allow paint to dry before proceeding to the next step.
18. Take the sheet metal screws provided and securely tighten. See DIAGRAM C.
19. Repeat these steps for the passenger front door. Your step is now ready to use!



Hoop II Step Installation Instructions

Part No's: 108221-1 / 108222-1 / 108224-1 / 108227-1

REAR DOOR INSTRUCTIONS

Vehicle Application:

Ford

'15- '20 F-150 Aluminum Body All Cabs/All Doors
'17- '20 Super Duty Aluminum Body All Cabs/All Doors
'18- '20 Expedition (All Doors)

**WAX YOUR
STEP ON A
REGULAR
BASIS TO
MAINTAIN
ITS LUSTER**

MATERIAL NEEDED:

Drill Motor, 5/16" drill bit, 1/8" drill bit, 2 - 1/2" wrench/socket, 2 - 7/16" wrench/socket, center punch, hammer, marker or pencil, matching exterior paint based on your vehicle paint code.

MATERIAL FURNISHED:

1 Hoop II Step Castings, 2 - Mounting Brackets, 1 - Hardware pack, 1 - Instruction sheet.

Diagram A

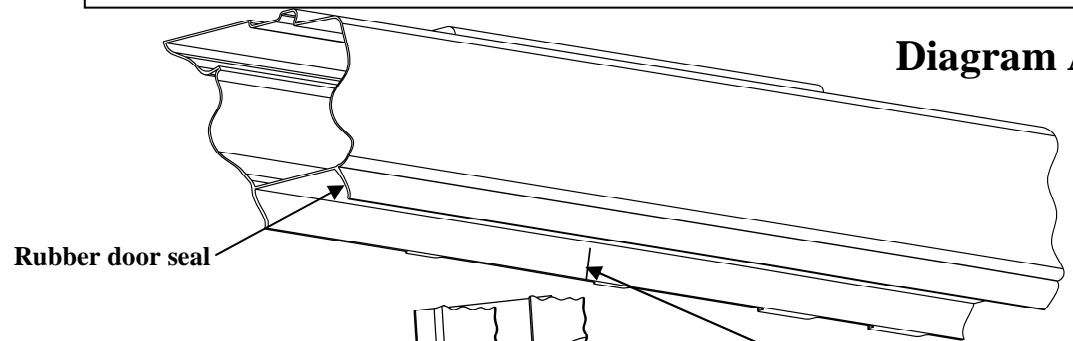

Diagram B

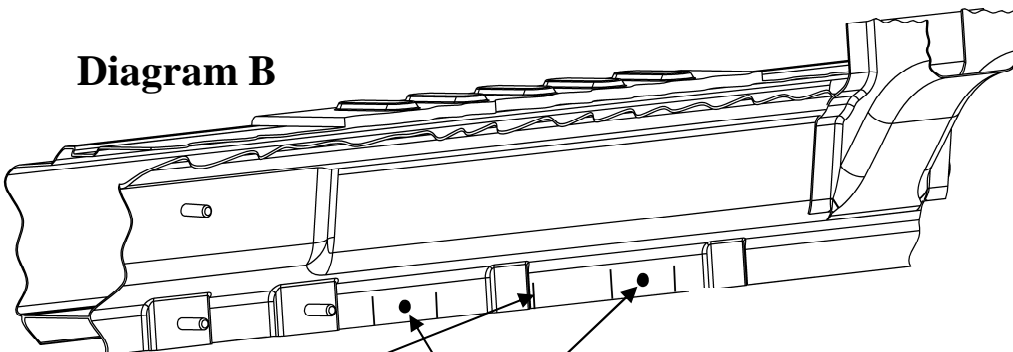

Diagram C

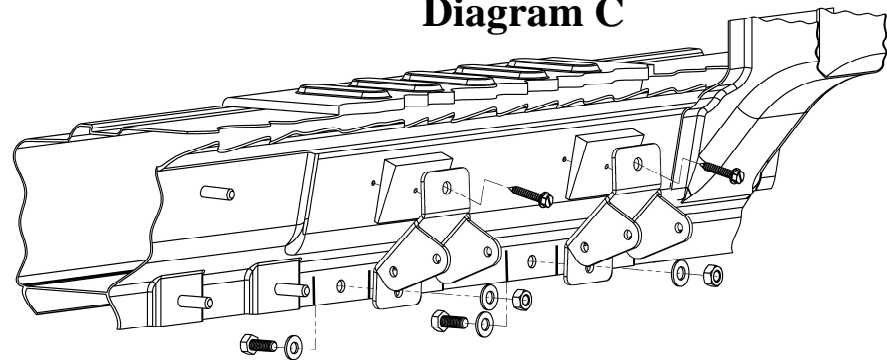
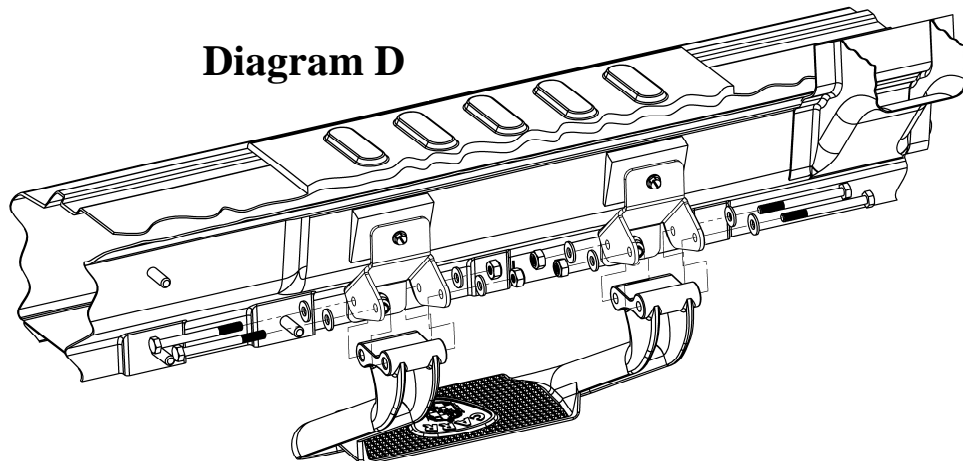

Diagram D





Hoop II Step Installation Instructions
Part No's: 108221-1 / 108222-1 / 108224-1 / 108227-1
REAR DOOR INSTRUCTIONS
Approximate installation time for one step – 45 minutes!

WARNING!

- ✓ Do not over tighten nuts and bolts as damage to the castings and/or stripping of the threads could result.
- ✓ FOR SAFE AND PROPER USAGE OF THIS PRODUCT, THE MOUNTING INSTRUCTIONS MUST BE FOLLOWED CAREFULLY AND COMPLETELY.
- ✓ The manufacturer and distributor of this product are in no way responsible for the consumer's failure to adhere to the warnings and directions of these instructions in the event of damage to the consumer's vehicle, other properties and/or personal injury.

To find our YouTube channel type as one word into the YouTube search box:

CARRproducts

Then go to the **Installation Videos** section for your specific video

1. NOTE: All diagrams shown are viewed from the driver side rear door. Open your rear door. For the proper position of the step, the front edge of the seat while in normal driving position should be in line with the center of the step. For personal preference or to avoid any obstruction underneath body metal, step can be moved left or right.
2. Take a marker or pencil and mark a vertical line that lines up with the front edge of the seat on the pinch weld area of your vehicle. See DIAGRAM A.
3. Assemble the Mounting Brackets to the Step Casting as shown in DIAGRAM D. Hand tighten the hardware only.
4. When positioning the step against the body metal, be sure to avoid all bumps and screws to make sure that the step assembly is against a flat surface.
5. With both Mounting Brackets hand-tightened on the Step Casting, place the entire assembly against the inside of the rocker panel of the vehicle. Line up the center of the step with the center vertical marked line. (Be sure to avoid any bumps or obstructions on body metal.)
6. While holding the entire assembly in place, take a pencil or marker and mark all four outside edges of the Mounting Brackets as shown in DIAGRAM B.
7. Remove the Mounting Brackets from the Step Casting.
8. Place the Mounting Brackets back against the body metal between the marked lines. Use the holes in the Mounting Brackets to mark the holes on the body metal as shown in DIAGRAM B.
9. Center punch the marked hole.
10. Take a 1/8" drill bit and drill out the centered punched holes.
11. Drill out the 1/8" hole with the 5/16" drill bit.
12. After drilling, make sure that all burrs are removed.
13. Take your matching exterior paint and totally paint drilled holes to seal the aluminum metal. Allow paint to dry before proceeding to the next step.
14. Take the 5/16" hardware that is provided and securely tighten both Mounting Brackets to the vehicle. See DIAGRAM C.
15. Place the Step Casting inside each Mounting Bracket and use the 1/4" hardware provided and securely tighten each Mounting Bracket to the Step Casting. See DIAGRAM D.
16. Take a 1/8" drill bit and drill two more holes through the top holes that are located on each Mounting Bracket through the Wedge Washers into the body metal. (NOTE: These holes may need to be drilled at an angle on the rear doors.)
17. Take your matching exterior paint and totally paint drilled holes to seal the aluminum metal. Allow paint to dry before proceeding to the next step.
18. Take the sheet metal screws provided and securely tighten. See DIAGRAM C.
19. Repeat these steps for the passenger rear door. Your step is now ready to use!