

# Hoop II Multi-Mount Step Installation Instructions

Part No's: 104991 / 104992 / 104994 / 104997



## Vehicle Application:

### **FORD**

'98-'11 Ranger 2-Door Only

### **MAZDA**

'98-'09 B-Series Pick-up

### **MATERIAL NEEDED:**

Drill motor, 5/16" drill bit, pencil, center punch, two 1/2" wrenches.

### **MATERIAL FURNISHED:**

Two step castings, four zinc plated steel brackets, four M Brackets, two hardware packs and instruction page.

1. Before positioning the M Bracket and step assembly against the body metal as shown in **Diagram A** assemble the M Brackets together with the steel mounting brackets only. NOTE: Do not attach the step castings to the steel brackets at this time.
2. Use the 5/16" x 3/4" hex bolts

and other 5/16" hardware provided and securely bolt together the steel brackets and M Brackets.

3. Now place the step casting up into each steel bracket. Use the 1/4" hardware provided and securely tighten all hardware. See **Diagram A**.

4. For the proper position of the step, the front edge of the seat while in normal driving position should be in line with the center of the step. For personal preference or to avoid any obstruction underneath body metal, step assembly can be moved left or right.

5. Once the desired position of the step as been found, take a pencil and mark the center of the step on the painted body metal of your truck, on the bottom of the rocker panel.

NOTE: This operation is much easier to do while on your back. Refer to **Diagram B**.

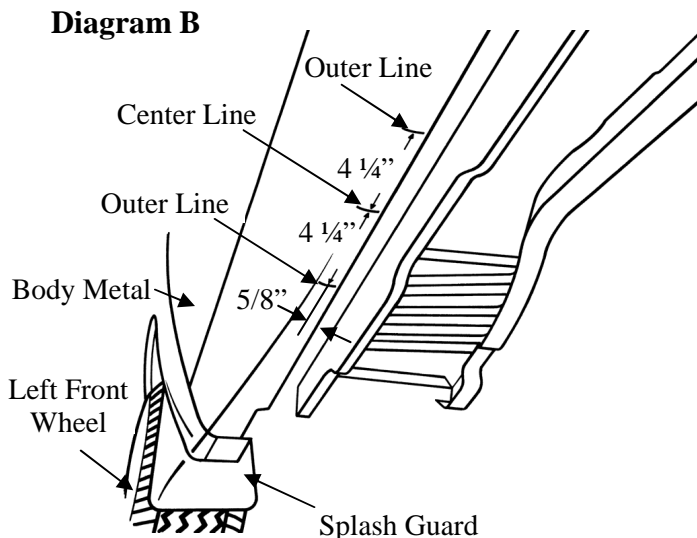
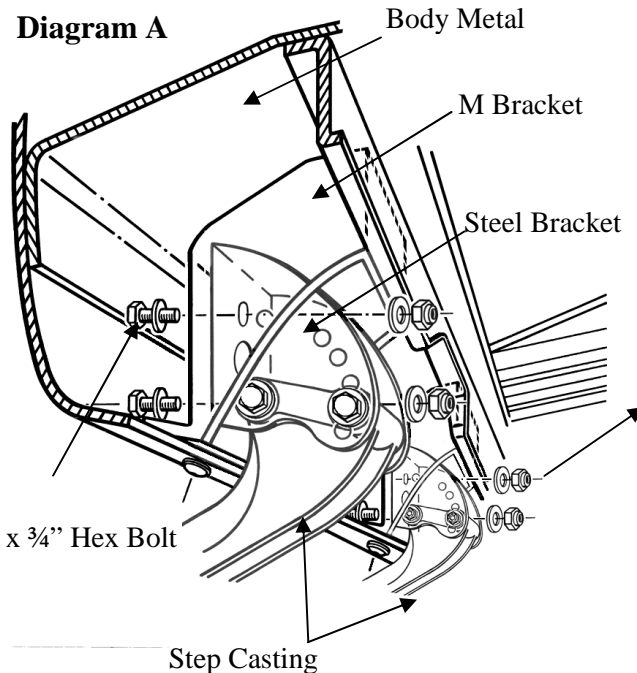

6. Measure 4-1/4" from each side of the marked center line on the same body metal surface.
7. Measure 5/8" in from the edge of the body metal, and mark a line across the marked outside lines. Refer to **Diagram B**.
8. Center-punch where the lines cross, then drill them out with 5/16" drill bit.

**WAX YOUR STEP ON A  
REGULAR BASIS TO  
MAINTAIN ITS LUSTER**

# Hoop II Multi-Mount Step Installation Instructions

Part No's: 104991 / 104992 / 104994 / 104997

## WARNINGS!

- ✓ Do not over tighten the nuts and bolts or damage to the castings and or stripping of the threads could result.
- ✓ FOR SAFE AND PROPER USAGE OF THIS PRODUCT, THE MOUNTING INSTRUCTIONS MUST BE FOLLOWED CAREFULLY AND COMPLETELY.
- ✓ The manufacturer and distributor of this product are in no way responsible for the consumer's failure to adhere to the warnings and directions of these instructions in the event of damage to the consumer's vehicle, other properties and or personal injury.

**Diagram C**

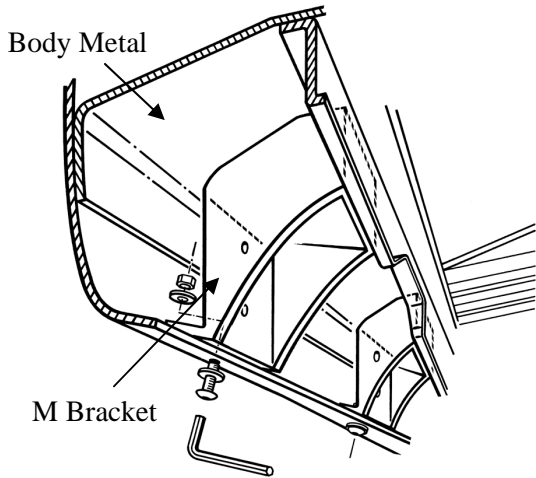

9. Move the entire step assembly over each hole. Take the 5/16" buttonhead bolts, Allen wrench, and hardware provided, and hand tighten each M Bracket. Refer to **Diagram C**. NOTE: If the holes don't line up perfectly, oversize the holes in the M Brackets until the holes line up. IMPORTANT: The body metal should not protrude beyond the M Bracket where the step will mount! If it does, oversize the holes in the M Brackets until the edge of the body metal is flush with the flat mounting area of the step. Refer to **Diagrams D & E**.

**Diagram D**

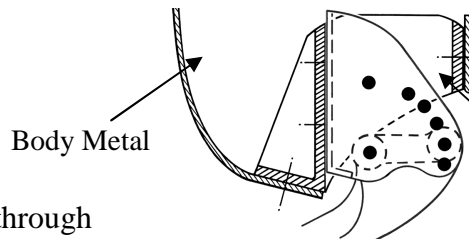

**CORRECT ALIGNMENT**

**Diagram E**

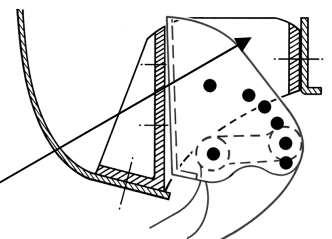

**INCORRECT ALIGNMENT**

10. Take your drill motor and drill a 5/16" hole through the body metal and the center of the back side of the M Bracket. This hole will have to be drilled at an angle unless you have a 90 degree drill motor. Refer to **Diagram F**.

**Diagram F**

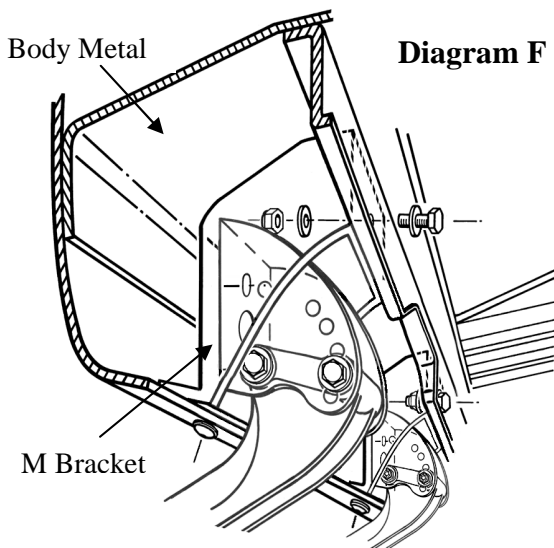

11. Take the remaining 5/16" hardware and bolt the M Brackets to the body metal.
12. Tighten all hardware securely.
13. Repeat the same procedures for the other side.
14. To maintain the luster of your steps, polish them with aluminum polish as often as you clean your vehicle.