

Hoop II Multi-Mount Step Installation Instructions

Part No's: 102551-1 / 102552-1 / 102554-1 / 102557-1



Vehicle Application:

JEEP
'97-'06 TJ Wrangler

MATERIAL NEEDED:

Drill motor, 3/8" drill bit, 1/8" drill bit, pencil, Phillips screw driver, center punch, two 1/2" wrenches, two 7/16" wrenches, and silicone.

MATERIAL FURNISHED:

1 casting, 2 zinc plated steel brackets, instruction page and 1 hardware pack.

(Important! Not all of the parts in these hardware packs may be needed for proper installation).

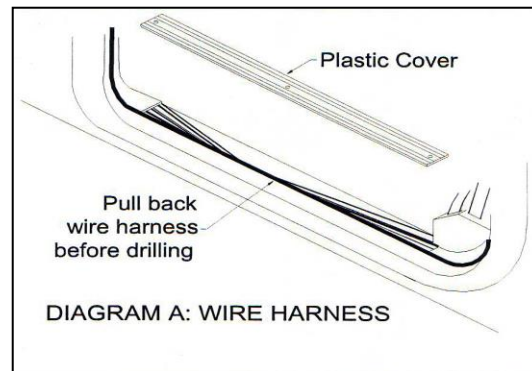

IMPORTANT Note: These larger holes are not used to install these steps.

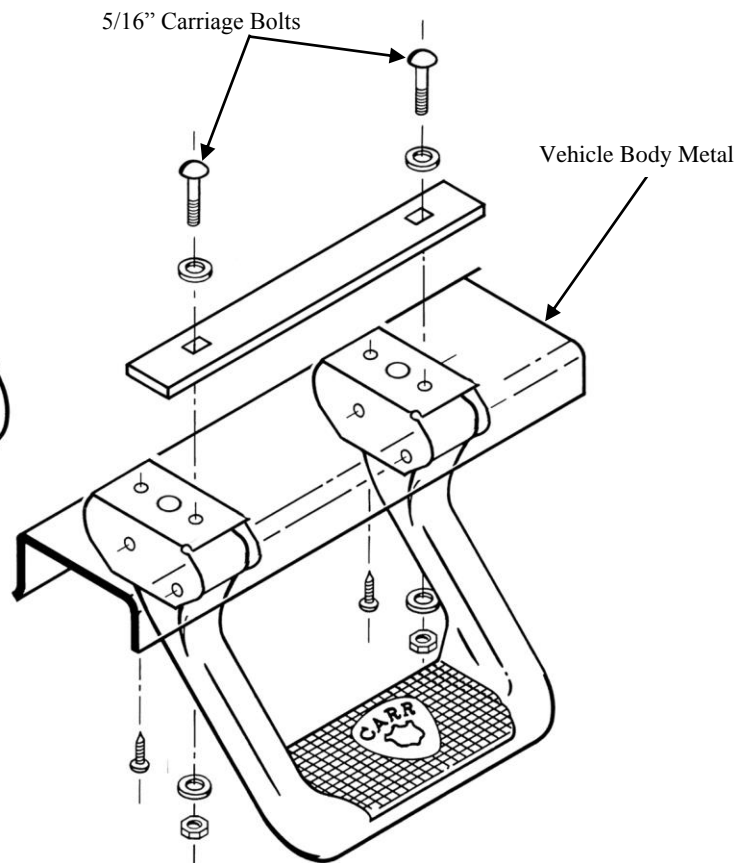
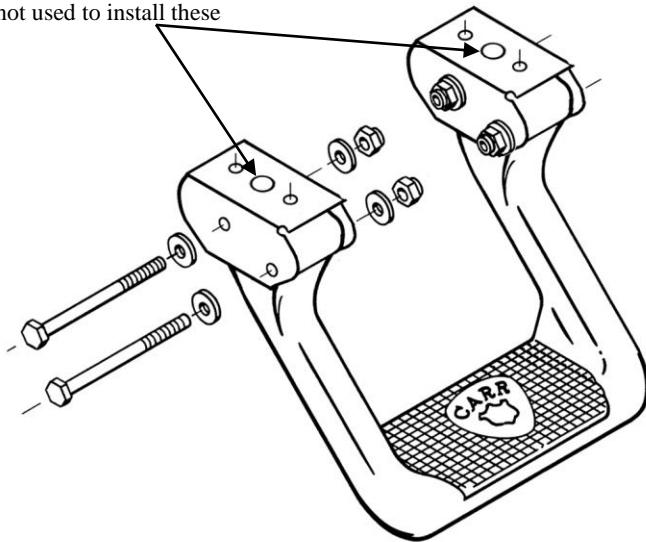

**WAX YOUR STEP ON A
REGULAR BASIS TO
MAINTAIN ITS LUSTER**



Hoop II Multi-Mount Step Installation Instructions

Part No's: 102551-1 / 102552-1 / 102554-1 / 102557-1



WARNINGS!

- ✓ Do not over tighten the nuts and bolts or damage to the castings and or stripping of the threads could result.
- ✓ FOR SAFE AND PROPER USAGE OF THIS PRODUCT, THE MOUNTING INSTRUCTIONS MUST BE FOLLOWED CAREFULLY AND COMPLETELY.
- ✓ The manufacturer and distributor of this product are in no way responsible for the consumer's failure to adhere to the warnings and directions of these instructions in the event of damage to the consumer's vehicle, other properties and or personal injury.
- ✓ **REFER TO DIAGRAM "A" WIRE HARNESS. STEP "8" ON THIS PAGE MUST BE FOLLOWED, IF NOT ELECTRICAL DAMAGE TO YOUR VEHICLE MAY OCCUR.**

1. For the proper position of the step, the front edge of the seat while in normal driving position should be in line with the center of the step. For personal preference or to avoid any obstruction underneath body metal, step can be moved left or right.
2. Assemble the steel brackets to the step as shown in the diagram, but only hand-tighten.
3. When positioning the step against the body metal be sure to avoid all bumps and screws to make sure that the step is against a flat surface.
4. When the desired location is found, while holding the step in that position, take a pencil and mark around the zinc plated steel mounting brackets and mark the 1/4" hole at the back of each bracket.
5. Remove the zinc plated steel mounting brackets from the step and place them back into the same place where you marked around these brackets and marked the 1/4" hole.
6. While holding the above bracket in this position, mark the 5/16" hole at the other end of the bracket on the body metal (not the center 1/2" hole).
7. Center-punch the 5/16" and the 1/4" marked holes for each bracket.
8. *REFER TO DIAGRAM "A" WIRE HARNESS. Remove the plastic cover that is holding the carpet down and move the wire harness out of the way before drilling out the hole for the next step as shown on the diagram. Do this procedure for both sides of your vehicle, because the wire harness may be on either side.
9. Take a 1/8" drill bit and drill out the centered punched holes.
10. Replace the 1/8" drill bit and drill out the 1/8" hole for the marked 5/16" hole with a 3/8" drill bit.
11. After drilling, make sure that all the burrs are removed.
12. Place the steel brackets back on the vehicle where the holes were drilled.
13. Use the 5/16" x 1" Carriage bolts to go through the 11" steel strap and the 3/8" holes in the body metal and securely tighten the brackets to the vehicle. (See Diagram) The steel strap will be visible when door is open.
14. Take the 5/8" sheet metal screws provided and securely tighten the brackets using the 1/8" drilled hole where the 1/4" marked hole was.
15. Re-install your carpet protectors with the screws that were removed.
16. Place the step back into the mounted steel brackets with the 1/4" hardware provided and securely tighten.
17. Check again and securely tighten ALL hardware.
18. We advise putting silicone sealer around the areas where the zinc plated steel mounting brackets contact the body metal.
19. After one month of use, go back and give all the hardware a final tightening.