

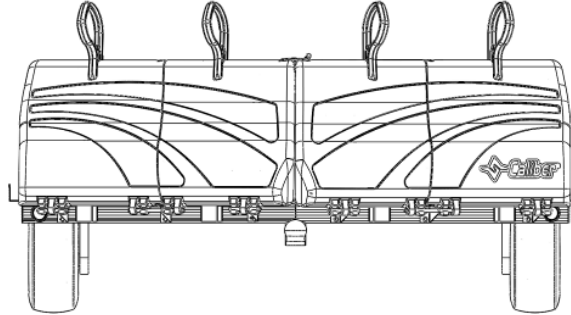

Product Update – V-Front Ramp Shield p/n 13404



New Bracket Adapter kit for front lips on Trailers p/n CA0209

Caliber announces an additional bracket adapter kit for Sled Bed and Aluma Trailers. Trailers that have a 2" front lip now can add this adapter kit for utilization of the V-Front Ramp Shield. Kit will be sent directly to customers this season; 2010-11 season will be included on our price list.

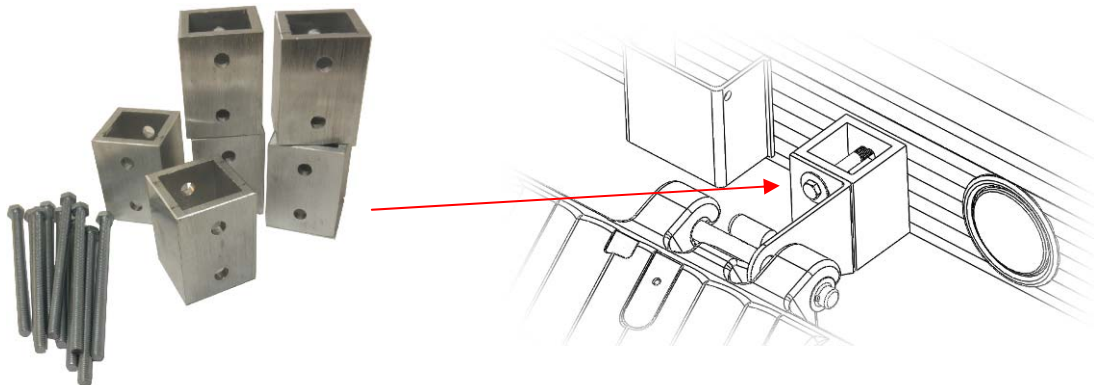

PRODUCT TEST

THE CALIBER V-FRONT RAMP SHIELD LOAD WARRIOR

Like most ATV owners, nearly every time we head out for a ride we have to haul our ATV. We prefer to use a trailer rather than make the harrowing ride up ramps into the back of our pickup, but even with a trailer, the loading is not always easy, and towing in the slip stream of our truck often pelts the machines with road grime and grit. Recently we've found a unique solution for both problems.

HIGH CALIBER SHIELD

Caliber is a company that specializes in everything you could need to make loading and hauling your ATV, UTV, snowmobile, or practically anything else you can get onto your trailer easier. They don't offer exhaust pipes, tire & wheel kits, or riding gear, but they do have you covered when it comes time to tow and go. A quick check of their web site revealed just what we needed: the V-Front Ramp Shield.

The V-Front Ramp Shield is an aerodynamic shield for the front of your trailer that pulls double duty. On the highway the V-Shield directs mud, road grit, and anything else your tires find up and over the machines, or much like a modern day suit of armor, heavier debris is deflected off. When you get to the ride area, the shield flips down into a sturdy set of ramps, allowing you to drive right off the front of the trailer with no other ramps necessary. We were anxious to give it a try!

BOX SET

The Caliber V-Front Ramp Shield has been developed as the first shippable V-Front Ramp shield. It arrived as carefully handled by UPS as anything else, so we're glad they are made for abuse. Inside the tough, well packed box we found four ramp doors, a hardware packet, and instructions. Thankfully the Caliber shield was designed to fit in a box that

keeps UPS from jacking the shipping price, and we appreciate the thought that went into the product, even from this standpoint. Now it was time to get to work!

It's the details that make a difference, and a quick inspection of the parts showed all the hallmarks of a carefully designed, well thought out product. The ramp/shield doors are blow-molded of a super tough, weather resistant plastic with lots of cross webbing for stiffness, rigidity, and durability, and holes have been predrilled where needed. There area all

types of manufacturing processes that went in to making the finished product, and blow molded shield aside, there are injection molded LowProGripGlides and handles, extruded grips, a rubber strap, and stamped and machined metal for the hardware. All these processes have different manufacturing characteristics, but the individual parts are quite impressive both on their own and as part of the assembly. A set of clear instructions is provided, and we were also very happy to find stainless steel fasteners and brackets for corrosion resistance, which only makes

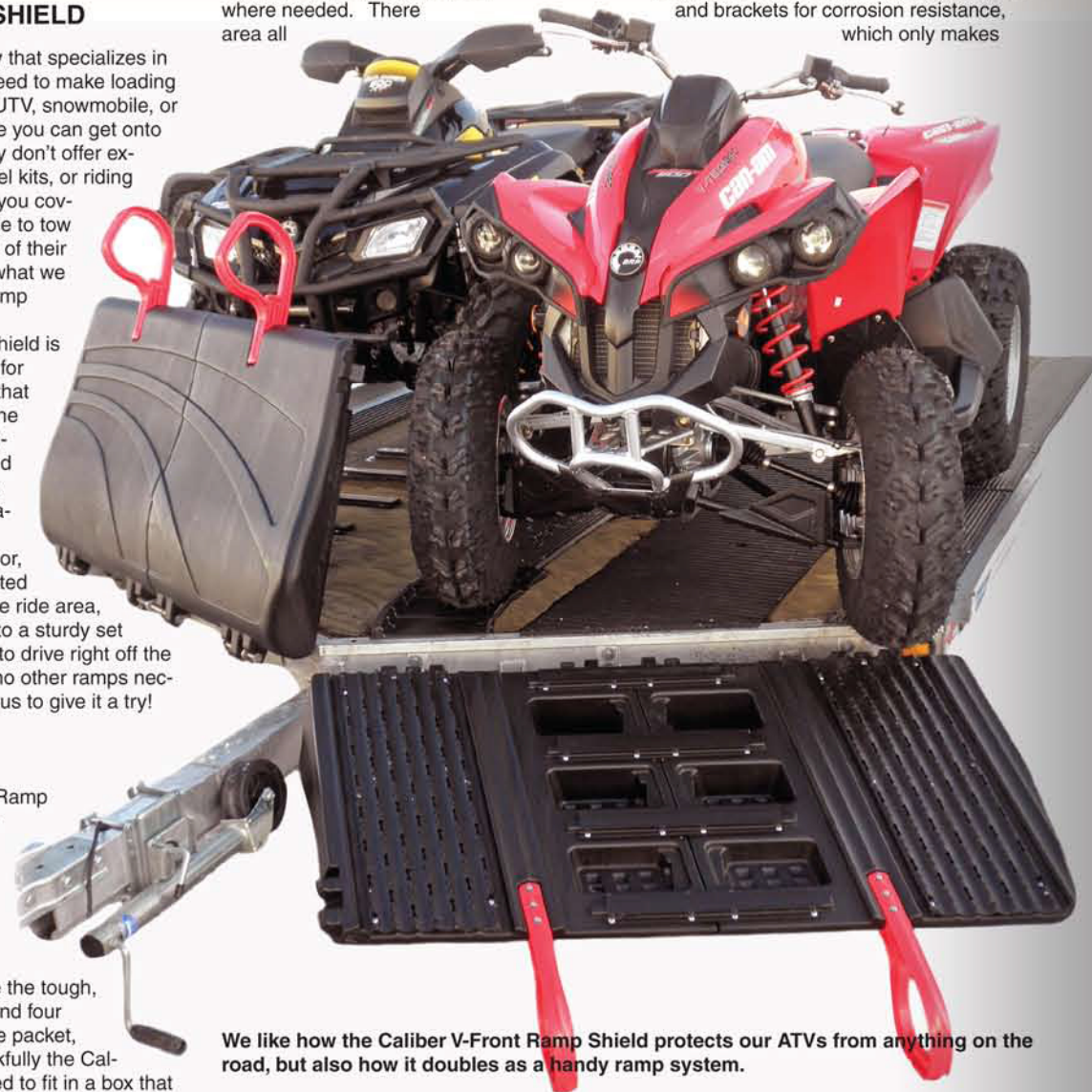

We like how the Caliber V-Front Ramp Shield protects our ATVs from anything on the road, but also how it doubles as a handy ramp system.

PRODUCT TEST

sense with an aluminum trailer. The kit also lists the common tools required, and Standard rather than Metric fasteners are used.

Each step of the instructions detailed the parts and tools needed, and it was easy to figure it out by looking at the diagram. It was fun actually! One thing we recommend is a cordless screwdriver, hopefully with an adjustable slip clutch that will disengage at whatever setting you choose. When drilling screws into plastic, it's a fine line between just enough torque to hold the part and too much which strips out the hole. The instructions warn at nearly every step to NOT OVERTIGHTEN the screws, and it's good advice. We set our screw gun to the minimum torque and worked up to what we felt was enough to do the job. On the Craftsman driver we used, it was set at position 4. After the door panels were joined, cross braces are added, and tread fastened down, it was time to install on the trailer.

When placing the V-Shield on the trailer, it's much easier to have a buddy. Place the V between the left and right ramp doors on the center of the trailer, measure and drill holes as specified for pivot brackets, and install mounting bolts through trailer, but leave them a little loose for adjustment. (Note: Because of the huge number of trailer manufacturers, you may need a spacer behind the pivot bracket if the trailer frame has a lip in the aluminum extrusion. Caliber has you covered here too and can provide spacers if needed.) When all brackets are in place, adjust where they work best and then tighten them all down. When you're done, try it out in all positions.

The Caliber V-Front Ramp Shield was one of those rare aftermarket kits that was fun to put together, and total installation time was about 90 minutes. When done it looks great. We really like how it is lightweight, easy to fold down, and protects our machines while on the road!

BEHIND THE SHIELD

Installing the Caliber V-Front Ramp Shield means no more wrestling with ramps and excellent protection for whatever we are hauling. We also appreciate its durability: it won't dent like thin aluminum or become stone pecked, and we can hose it down or haul it in bad weather without worrying about rust or corrosion. As a bonus it also comes with Caliber's Lifetime warranty that covers their entire product line. Overall, the V-Front Ramp Shield is a well thought out product that delivers on its promise at the very competitive list price. The Caliber V-Front Ramp Shield serves our need for protection and for ramps. We like it!



The V-Shield came in a box delivered by UPS, and inside were all the parts and a handy set of instructions.

Do yourself a favor and use a cordless screw gun to install all screws. Be sure to set the clutch to the lowest setting, and gradually increase torque until the screws fully seat themselves. Whatever you do, don't over tighten them!



Assembling the V-Front Ramp kit was easy and fun! A few simple tools are all that is required but it's easier to have a buddy when mounting on the trailer. Total time for our kit was about 45 minutes.



It takes a lot of tooling and manufacturing operations to build the Caliber V-Front ramp shield. Here the ramp tread is formed in a die set. The female cavity of the mold is below, a male form above, and the plastic material fills the void between when the mold is shut by the press holding it.

Learn more about trailer hitches and towing we have.