



## B&W Trailer Hitches

1216 HWY 224 / PO Box 186  
Humboldt, KS 66748

**NOTE:** *we recommend reading instructions before beginning the installation.*

# Heavy Duty Receiver Hitch Installation Instructions

## Model HDRH25122

### Vehicle Make and Years

1972-1993 Dodge 1/2, 3/4, and 1 Ton trucks with factory bumper

#### PARTS LIST

ID	DESCRIPTION	QUANTITY
1	- HITCH CENTER SECTION	1
2	- DRIVER SIDE PLATE	1
3	- PASSENGER SIDE PLATE	1
4	- TRAILER PLUG BRACKET	1
5	- 1/2-13 X 2" HEX HEAD CAP SCREW	6
6	- 1/2-13 X 1-1/2" HEX HEAD CAP SCREW	9
7	- 1/2-13 HEX FINISH NUT	15
8	- 1/2" SPLIT LOCK WASHER	15
9	- SPACER 3/16 X 1 X 1 1/2	6
10	- SPACER 3/16 X 1 1/4 X 1 1/2	6
11	- SPACER 3/16 X 1 1/2 X 3	2
12	- #14 X 3/4 SHEET METAL SCREW	2

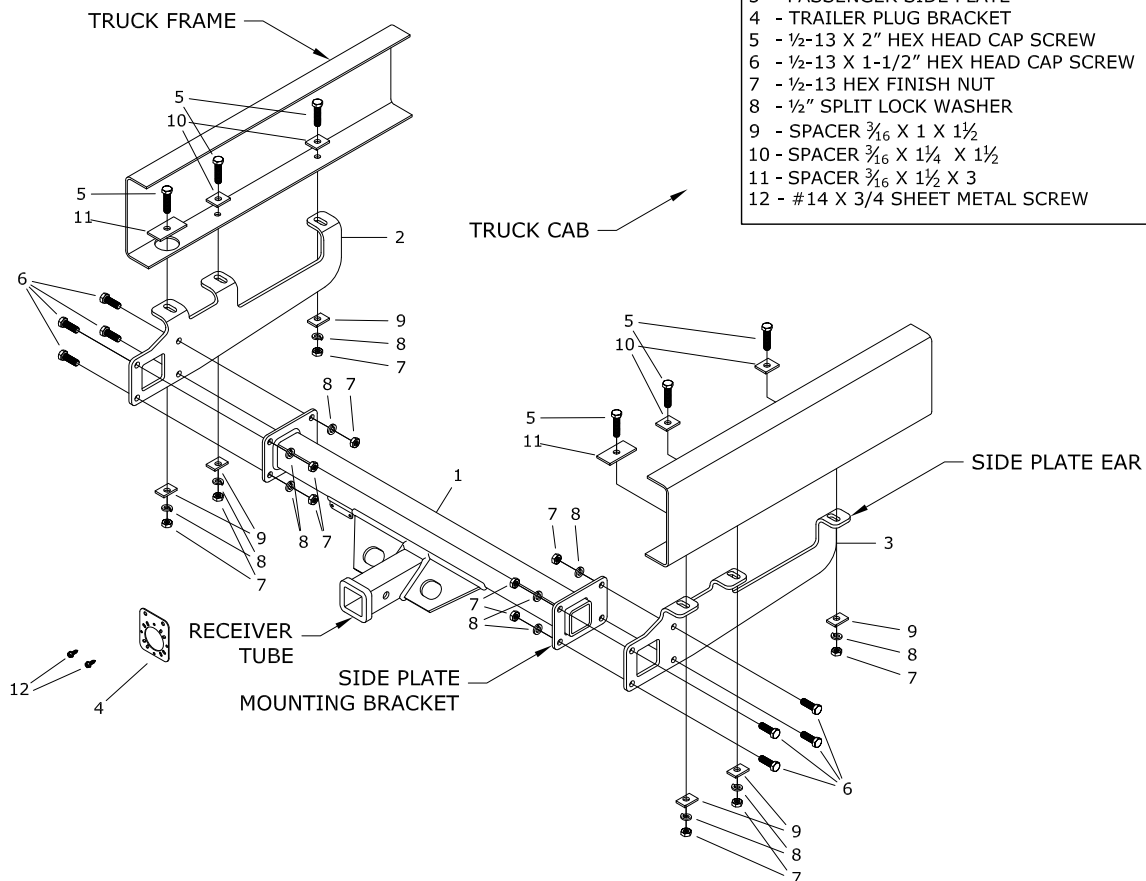

## BEFORE INSTALLING

### WARNING

Although this hitch contains a V-5 rating of 16,000 lb. WC, the tow vehicle manufacturers recommended towing capacities should under NO circumstances be exceeded.

### WARNING

B&W Receiver Hitches are designed to fit vehicles as produced by the factory. Any equipment or accessories added to the vehicle may affect the fit of the hitch. B&W will not warranty the hitch if any alterations are made during the installation process. Occasionally there are rare vehicle options that may prohibit the hitch from installing properly. Please contact the manufacturer for support if this is the case.

### WARNING

Always use safety chains while towing. Crossing the safety chains under the tongue of trailer may prevent some damage to the trailer if detachment occurs.

### WARNING

Periodically inspect hitch, making sure that all fasteners are tightly secured.

## BEFORE INSTALLING

This receiver hitch may require slight modification to the frame or other structure of the vehicle such as drilling or relocating equipment so that the hitch may be installed in the proper location. It is very important to make sure that you have the correct hitch for your application before any modifications to the vehicle are made.

On most vehicle models from 1972 to 1993 the spare tire and spare tire hanger bolt will need to be removed before installing the hitch. On models from 1994 to 1996 the rear exhaust hanger bracket will need to be removed before installation.

In some models, the hitch will interfere with the spare tire or spare tire carrier not allowing them to be located in their original position. On most one ton pickups with dual wheels, the spare tire must be relocated entirely. On other trucks the spare tire and carrier need to be lowered so that they will clear the hitch. This can be accomplished by lowering the hinge point of the carrier and adding spacers between the tire and the portion of the truck that it rests against under the truck bed. A kit is available from B&W if needed which will lower the spare tire. This kit consists of three foot pads and full thread bolts for adjustable spacing. Three holes will need to be drilled into the vehicle to mount the spacers.

Remove spare tire before installation. This will provide easier access to the frame. Be sure that the vehicle frame where the hitch will mount is free from debris or other material that may interfere with the installation.

## STEP 1: HITCH ASSEMBLY

Assemble the hitch as shown on the main diagram using the ½" x 1-½" long bolts, lock washers and nuts. Attach the side plates to the hitch center section with the "ears" of the side plates toward the out side as shown in the main diagram. Do not fully tighten the hardware at this time.

## STEP 2: POSITIONING HITCH

Position the hitch under the frame as shown in the main diagram. Align the slots in the rearward ears of the side plates with the large hole in the rear of the vehicle frame. Attach the hitch to the frame in these two locations with the hardware as shown. Make sure that the hitch is centered between the frame rails of the vehicle and that the receiver tube is parallel to the centerline of the truck. Tighten these two bolts so that the hitch is held firmly against frame. It may be necessary to use additional clamps.

## STEP 3: DRILLING

With the hitch temporarily secured to the frame, drill a ½" hole through the slots in the remaining side plate ears and into the bottom of the frame rails as needed for mounting the hitch. Drill holes approximately in the center of the bottom flange of the truck frame so that there is room for wrench clearance on the head of the bolts.

## STEP 4: MOUNTING HITCH

Install the remaining hardware as shown in the main diagram, fastening the hitch to the frame. On 1994 to 1996 models, use a 1-1/2" long bolt in the forward most ear of the side plate on the passenger side. This shorter bolt will provide clearance for the exhaust hanger bracket that was removed.

## STEP 5: TIGHTENING HARDWARE

Tighten the hardware on the connections between the frame and the side plates first. Torque the bolts to 80 foot pounds. Next make sure that the edges of the side plate mounting brackets on the center section match up with the bottom and rearward edges of the side plates and tighten these connections. Torque these bolts to 80 foot pounds as well. Remove any clamping devices installed during step 2. Replace exhaust hanger bracket on 1994 to 1996 models. On 1972 to 1993 models, relocate the spare tire to another part of the vehicle or use spacers to install it under the truck bed so that the tire and carrier do not interfere with the hitch.

## STEP 6: OPTIONAL BRACKET INSTALLATION

An optional trailer plug mounting bracket has been included with this hitch. If your vehicle does not have a place to mount the trailer wiring receptacle, this bracket will accept many different receptacles on the market. Mount the bracket using the two self-tapping sheet metal screws as shown in diagram 6.1. Be aware of ground clearance limitations that this wiring plug bracket or any other may add to the hitch.

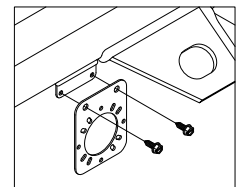

FIGURE 6.1