



NOTE: We recommend reading instructions before beginning the installation.

Companion Slider Hitch Installation Instructions

20,000 LBS. TRAILER WEIGHT

5,000 LBS. TRAILER TONGUE WEIGHT

Model 3405

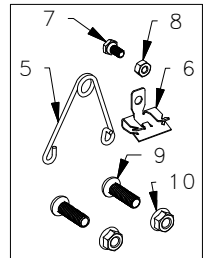
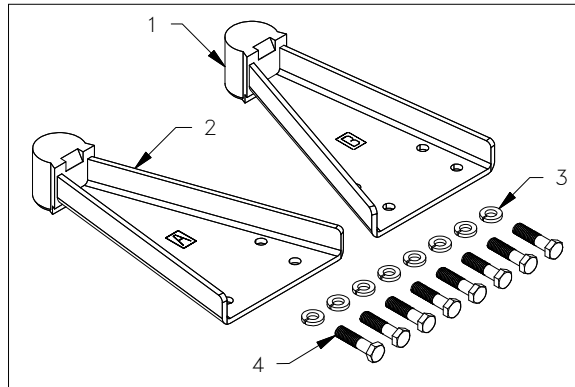
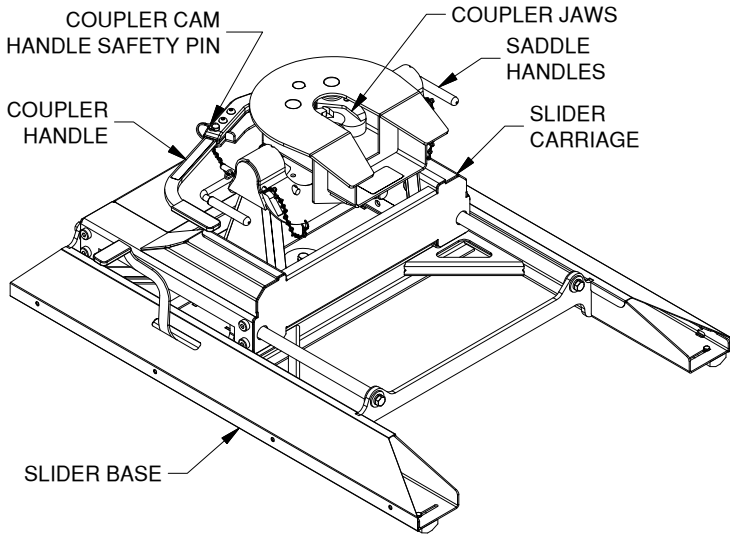

BASE BOLT BAG (RVB3405)		
ITEM	DESCRIPTION	QTY
1	Pivot Arm A	1
2	Pivot Arm B	1
3	1/2" Split Lock Washers	8
4	1/2" X 2" Hex Cap Screw	8

COUPLER BOLT BAG (RVC3006)		
ITEM	DESCRIPTION	QTY
5	Wire Torsion Spring	1
6	Mounting Clip	1
7	1/4" X 1/2" Cap Screw	1
8	1/4" Finish Nut	1
9	3/8" Button Head Cap Screw	2
10	3/8" Lock Nut	2

REQUIRED TOOLS

Installation of the slider hitch requires a large torque wrench capable of measuring 80 ft-lbs, a 3/4" socket, a 7/16" and 9/16" socket or wrench, and a 7/32 allen wrench.

ATTENTION: The Slider accessory will work with all Turnoverball gooseneck hitches **except** GNRK1309 and GNRK1257.

⚠ WARNING Failure to comply with the safety information in these instructions could result in serious injury or death.

- ⚠ Read all installation and operating instructions along with all labels before using this product.
- ⚠ Without proper knowledge, towing can be a dangerous activity. Understand all the risks involved with towing before proceeding.
- ⚠ Do not modify this product in any manner. Doing so could alter its integrity and lead to a loss of attachment between the trailer and the tow vehicle.
- ⚠ Regularly check that all bolted connections are at the correct torque specification. A visual inspection should be performed before each time you tow.
- ⚠ Do not exceed tow or tongue rating of coupler, tow or tongue rating of hitch, or tow or weight ratings of truck or trailer. See vehicle and trailer manufacturer information for ratings. Exceeding these ratings may cause damage to towing components or loss of attachment between the trailer and truck.
- ⚠ Adding components to the chassis of any vehicle can be hazardous. There is potential for damage to vehicle, injury from tool usage and many other hazards. This installation must be completed by someone who is aware of the hazards involved. This person must be knowledgeable of proper safety procedures for a vehicle installation of this nature, and for usage of the equipment required to perform the installation.

PREPARING TO INSTALL

⚠ WARNING: Components of the slider hitch are heavy and cumbersome to handle. Failure to use proper lifting techniques and an adequate amount of people when moving and handling these parts could result in property damage or serious injury.

⚠ WARNING: Whenever the slider base is being moved, the slider handle must be in the locked position, and the carriage must be unable to slide, see Figure A1. Failure to ensure that the handle is in the locked position can lead to property damage, or serious injury.

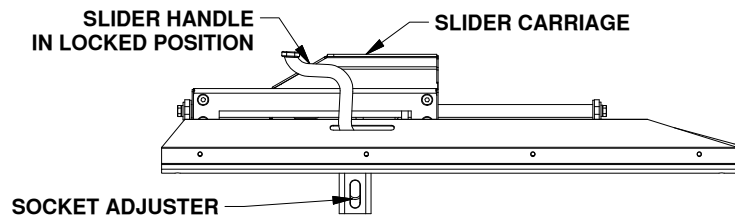

Figure A1: View of driver side of Slider Base.

INSTALL SLIDER BASE

NOTICE: If truck is equipped with a removable bed liner or mat it should be removed or it must be cut to allow the base to directly connect with the bed. It is acceptable to install the RV base over a spray-in bed liner.

1. Check that the bed of the truck is clean, and that all debris is removed before beginning installation.
2. Loosen the four 1/4" cap screws securing the polyurethane pads on either side of the slider hitch, see Figure B1.

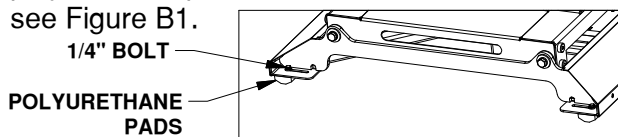

Figure B1: View looking at the Slider Base from the cab of the truck.

3. Locate the GN latch pin handle of the Turnoverball™ Gooseneck Hitch in the driver side fender well. Retract the GN latch pin handle all the way until it stops and then rotate it clockwise. Remove the Turnoverball from the GN hitch receiver socket.

4. With the help of 2 or 3 people, carefully lift and position the slider base into the GN hitch socket in the back of the truck bed. Re-engage the GN latch pin handle by turning it counter-clockwise.

⚠ WARNING: Check the latch pin under the truck. Make sure that the latch pin has passed through both sides of the socket and that the pin is covered up inside the socket by the socket adjuster, see Figure A1. If the pin is visible inside the GN hitch socket, retract the GN latch handle and use the draw-down bolt to adjust the socket adjuster.

5. Square the slider base legs with the ribs of the truck. Position the polyurethane pads so that they are both in a bottom rib along their entire length, see Figure B3. Tighten the four 1/4" bolts holding the pads to the base.

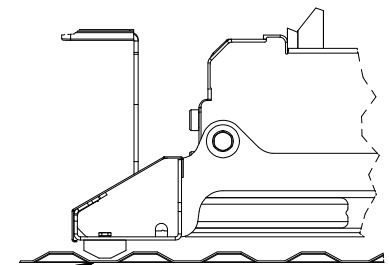

Figure B3: Back view of the driver side leg of the Slider Base.

6. Secure the base of the Slider to the truck bed by tightening the 1/2" x 3-1/2" draw-down bolt to 80 ft-lbs, see Figure B4.

WARNING: DO NOT lubricate the draw-down bolt, the torque value is for dry threads only.

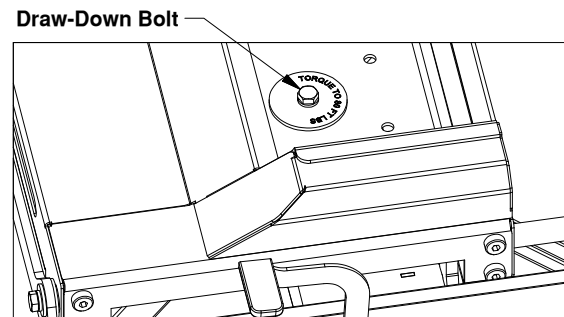

Figure B4: View looking into the top of the Slider Base.

INSTALL PIVOT ARMS

1. Mount the pivot arms using one of the six different locations illustrated in Figure C1. These six locations allow flexibility in coupler height and distance from the cab. Choose a location so that your trailer will be as level as possible and have adequate turning clearance while in the towing position (with the slider in the forward position). See warnings after step 2.

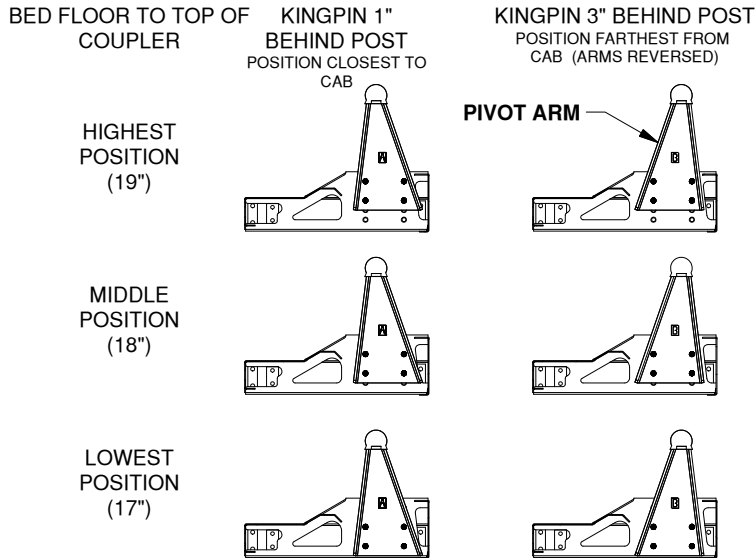
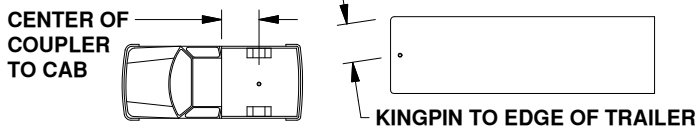

Figure C1: Cut away view of slider carriage arm positions.

2. With the flat side of the pivot arm flat against the bolt plate in the slider base, install four 1/2" x 2" bolts and four 1/2" split lock washers for each arm. Torque each bolt to 80 ft-lbs.

- WARNING:** Check the clearance between the truck cab and the trailer in both the towing position and the maneuvering position. Compare the measurement taken from the center of the Slider Coupler to the cab, to the measurement taken from the center of the king pin to the farthest forward corner point of the trailer. These measurements will allow you to see how much clearance you will have between the cab and the trailer while towing and turning.



- WARNING:** Check the clearance between the bed side and the underside of the front of the trailer and to allow adequate clearance for the pitch and roll of the trailer while towing.

- WARNING:** Parts of the trailer may strike the tailgate when sliding the companion rearward. Check the clearance between the tailgate and trailer components such as the trailer tongue or pin box. Failure to check clearance may cause property damage.

INSTALL LEVELING KIT

1. Locate the 1/4" cap screw and nut, along with the wire tension spring and mounting clip. Pass the 1/4" cap screw through the mounting clip and the wire spring, as shown in Figure D1. Thread the 1/4" lock nut onto the 1/4" cap screw. Tighten the lock nut just enough that the spring will stay in place but will still be able to rotate around the bolt if needed, see Figure D2.

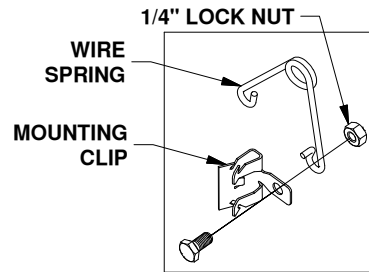

Figure D1: Leveling kit parts.

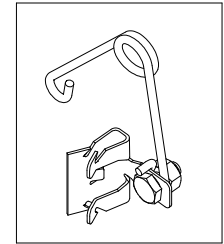

Figure D2: Assembled leveling kit.

2. Locate the flange which will be closest to the truck cab on the driver side pivot arm, see Figure D3. The clip should be placed so that when the spring's coil is in line with the edge of the arm there will be 1/2" of clearance between the bottom of the rubber bumper and the top of the spring, see Figure D4. Drive the clip securely onto the flange with a hammer.

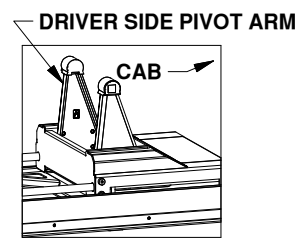

Figure D3: Base view.

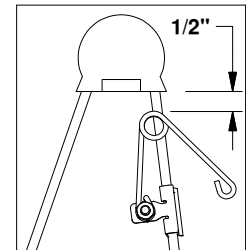

Figure D4: Driver side pivot arm.

INSTALL COUPLER HANDLE

1. Locate the two 3/8" x 1-1/4" button head cap screws and the two 3/8" flanged lock nuts provided in a bolt bag. Pull out the coupler arm and pin it with the safety locking pin near the base of the arm as shown in figure E1.

CAUTION: Pulling the arm out away from the coupler creates a pinch point. Use caution when installing the handle to avoid injury.

Using the button cap screws and the lock nuts, attach the coupler handle to the arm and tighten, see Figure E1. Pull out the coupler cam handle safety pin.

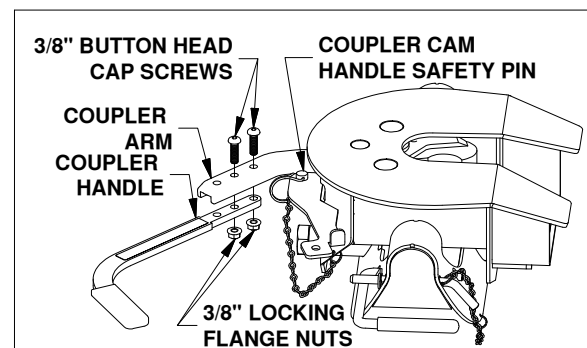

Figure E1: View looking down at side of coupler head.

INSTALL COUPLER

1. Lubricate the polyurethane bushings on top of pivot arms with high grade lithium grease (available at your local hardware/automotive store). Place the coupler over the pivot arms. (The saddle handles should be parallel with the Slider Base in the latched position.) Place the saddle lock pins through the saddle, then insert the hair pins through the holes in the end of the saddle lock pins to secure the coupler to the pivot arms, see Figure F1.

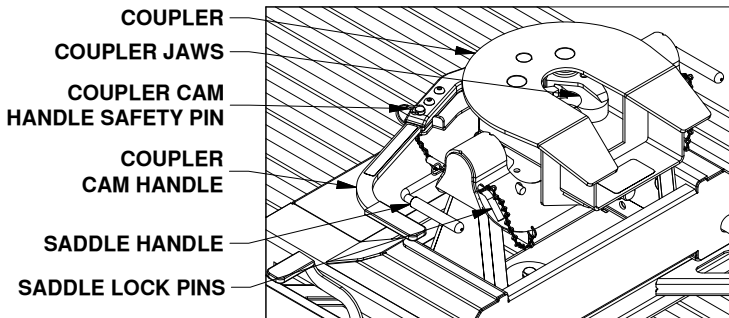

Figure F1: View of Slider Base and Coupler Head assembled.

2. Adjust the resting angle of your coupler plate by rotating the spring on the driver side pivot arm. Pulling the top of the spring away from the cab will increase the angle of the coupler plate. Set the angle of the coupler so that head will tilt away from the cab when coupling, see Figure F2. Tighten the 1/4" nut once the spring's orientation is set.

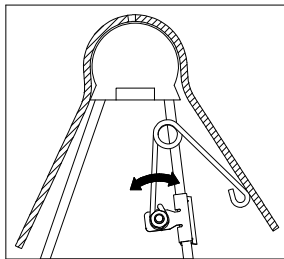

Figure F2: Cutaway view of driver side pivot arm and saddle.

ATTACHING TRAILER

Remove the coupler cam handle safety pin and rotate the cam handle to the open position. Adjust the height of the 5th wheel trailer so that the king pin plate is slightly lower than the top of the coupler. Back the truck towards the trailer, centering the trailers king pin in the Coupler, until the king pin has engaged the jaws. Ensure that the Coupler cam handle has completely closed before inserting the cam handle safety pin through the cam handle and the coupler. Hook up brake and lighting connections before towing.

PULL TEST

Have the truck stationary with the emergency brake on, the trailer wheels blocked and landing gear still resting firm on the ground supporting the weight of the trailer. Make sure no one is between the truck and trailer, return to the cab of the truck. Release the emergency brake and apply the trailer brakes. Try to pull the trailer forward with the truck. If the trailer is properly hooked up, the wheel blocks and trailer brakes should not allow the truck to move forward. If trailer is not hitched correctly, the trailer will separate from the truck. However, with the landing gear resting firmly on the ground, it will support the trailer and not allow it to drop or fall on the truck sides.

UNATTACHING TRAILER

Lower landing gear and block the trailer wheels. Raise the trailer until the tongue weight is removed from the truck. Then, unpin the Coupler handle and rotate to the open position to unlatch the jaws. If the jaws do not open, readjusting the landing gear may relieve pressure and allow them to open. Use the safety pin to lock the handle in the open position and when you are sure that the landing gear will support the trailer, move the truck forward to release the jaws from the kingpin. The jaws will always open when the pressure of the trailer is taken off the Coupler as the truck pulls away.

UNINSTALL HITCH

To uninstall the Slider Hitch, remove the saddle lock pins, grab the saddle handles and lift to remove the Coupler from the pivot arms. To remove the Slider Base, loosen the draw-down bolt and retract the Turnoverball gooseneck latch pin handle all the way out until it stops and then rotate it clockwise. With the help of 2 or 3 people, carefully lift and position the Slider Base out of the Gooseneck hitch socket.

⚠ WARNING: Do not use the Slider 5th Wheel Hitch with any device that changes the location of the king pin pivot point. The king pin on your trailer must rotate in the jaws of the Slider Coupler, see Figure G1. Preventing the king pin from rotating within the jaws of the Slider Coupler with a wedge, see Figure G2, or any other device, such as a Reese Sidewinder® or Reese Revolution®, could result in property damage, serious injury or death.

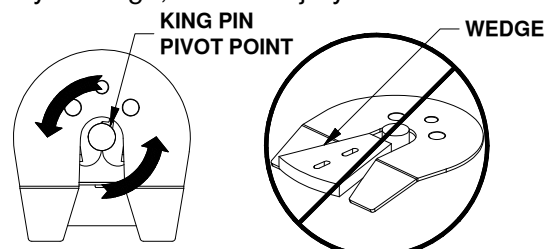

Figure G1: Top view of coupler head. Figure G2: Coupler Head with locking wedge.

SLIDER OPERATION

⚠ WARNING: Use extreme caution when moving the truck and trailer in the maneuvering position. Never exceed 5 mph (roughly walking speed) when in the maneuvering position, doing so may result in property damage, serious injury or death.

CAUTION: Use of the slider mechanism should only be attempted while on smooth flat terrain.

⚠ WARNING: The maneuvering position is only intended for parking maneuvers and not for towing. Using the slider in any other capacity could result in serious injury or death.

⚠ WARNING: Never hold on to the handle or force it in any direction while the truck is moving. Failure to stand clear of the handle when the slider is in operation could result in serious injury.

Moving from towing position to maneuvering position. (Figure H3 to H4)

1. While the trailer is coupled, set the trailer brakes and/or chock the trailer wheels.
2. Pull the handle toward the rear of the truck to move it to the unlocked position, shown in Figure H2.
3. Pull the truck forward slowly until the handle falls and is in the locked position, shown in Figure H1.
4. Release the trailer brakes, un-chock the trailer and maneuver the trailer as needed.

Moving from the maneuvering position to the towing position. (Figure H4 to H3)

5. Once the trailer is satisfactorily positioned, set the trailer brakes and/or chock the trailer wheels.
6. Pull the handle toward the rear of the truck to move it to the unlocked position, shown in Figure H2.
7. Move the truck slowly in reverse until the handle falls and is in the locked position, shown in Figure H1.
8. Release the trailer brakes and un-chock the trailer.

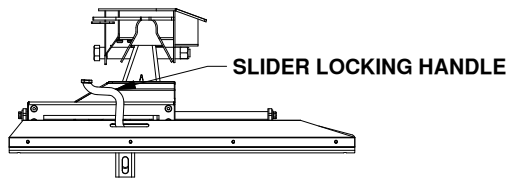

Figure H1: Side view of Slider Base. LOCKED HANDLE POSITION

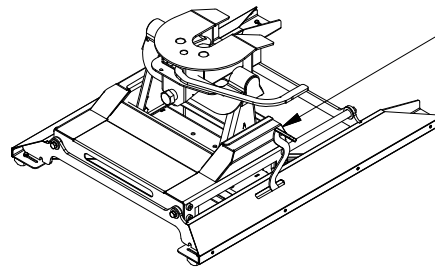

Figure H3: View of Slider Base with the Carriage in a forward position. TOWING POSITION

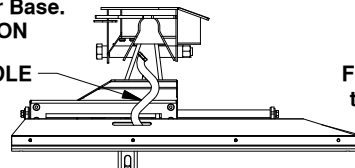

Figure H2: Side view of Slider Base. UN-LOCKED HANDLE POSITION

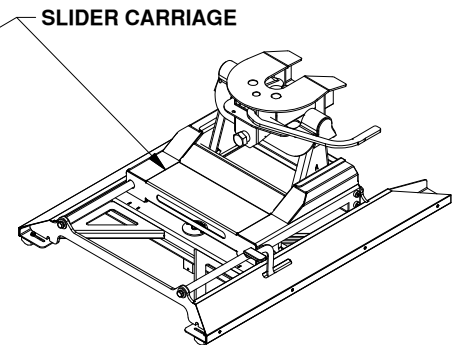

Figure H4: View of Slider Base with the Carriage in a back position. MANEUVERING POSITION

HELPFUL TIPS:

Approximately 15%-25% of the trailer weight should be on the hitch.

The height of the king pin box and pivot arms should be adjusted so that the trailer is approximately level for towing.

Allow adequate clearance between the bed side and the underside of the front of the trailer for pitch and roll of the trailer.

Lubricate top surface of coupler with automotive type chassis grease or use a nylon lube plate to provide a lubricated surface.

The Slider hitch was designed to be used with the Turnoverball™ hitch mounting system. Other uses will void the warranty and are expressly prohibited by B&W Trailer Hitches.

Grease jaws with automotive type chassis grease.

Grease the saddle through the grease zerk approximately every six months with multi-purpose grease. This allows the coupler to pivot freely, see Figure J1.

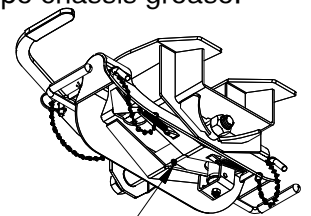

Figure J1: Underside view of Coupler Head