



**NOTE:** *We recommend reading instructions before beginning the installation.*

**WARNING:** *The tow vehicle's towing capacities should under NO circumstances be exceeded.*

# Turnoverball™ Gooseneck Hitch Installation Instructions

## Model 1400R

**Chevrolet & GMC (1973 - 1987)**

1/2 - 3/4 - 1 Ton Trucks

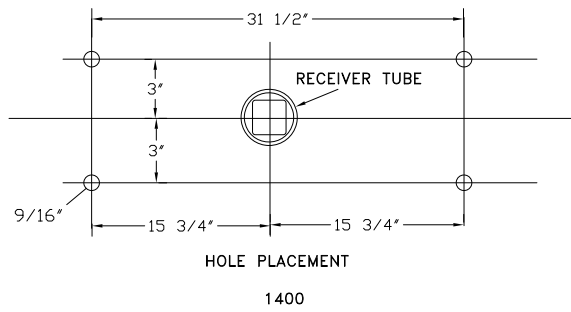
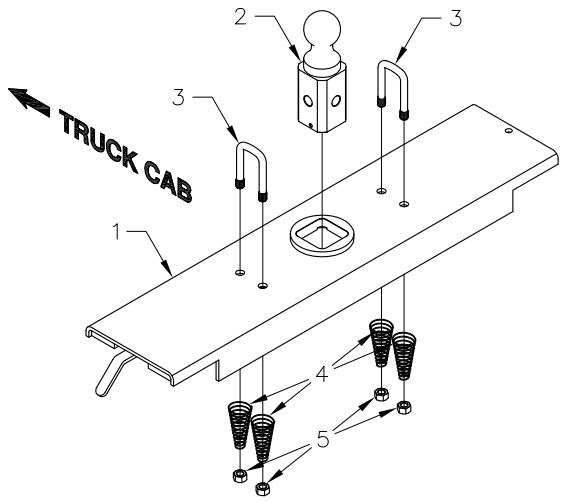

Mounting Kit Box (GNRK1400)		
ITEM	DESCRIPTION	QTY
1	Center Assembly	1
2	2-5/16" Ball	1
Mounting Kit Bolt Bag		
	1/2" X 1-1/2" Carriage Bolt	4
	1/2" Finish Nut	4
	1/2" Lock Washer	4
	1/2" Flat Washer	4
Safety Chain Kit Bolt Bag		
3	1/2" U-Bolt	2
4	Conical Springs	4
5	1/2" Lock Nut	4
	5/16" X 3/4" Carriage Bolt	1
	5/16" X 3/4" Cap Screw	1
	5/16" Flange Nut	1

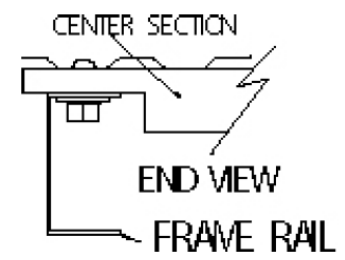

**NOTICE:** This product was designed to fit vehicles in their original, "as manufactured" condition. Compatibility with vehicles having replacement parts, or other modifications is not guaranteed. Inspect vehicle for modifications before installation of this product.

## BEFORE INSTALLING OVERHEAD LIFTING DEVICE

An overhead-lifting device, such as chain falls, engine hoist, or cable come-a-long, can be used to lift the center section of the hitch in place. Lower a loop of rope or chain through the 4" hole in the truck bed floor and attach it to the latch pin in the round hitch receiver tube in the center section. Use the lifting device to raise the center section until the round hitch receiver tube that protrudes from the center section fits in the 4" hole in the truck bed floor. Maintaining upward pressure may facilitate fastening the crossmember to the center section, especially if the truck bed floor has been distorted downward from heavy use. If you use an overhead-lifting device, it should be disconnected before squaring the center section across the frame, installing the sideplates and torquing fasteners.

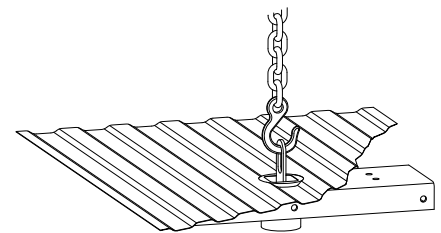

## **WARNING**

Most trucks have FUEL LINES and/or BRAKE LINES and/or ELECTRICAL WIRES located along the frame rails where B&W Turn-overball™ hitches install. Carefully examine the location of fuel lines, brake lines and electrical wires BEFORE INSTALLATION. Be certain you will not damage fuel lines, brake lines or electrical wires when positioning hitch components, drilling holes, tightening fasteners, and lifting and lowering the truck bed. The fuel tank vent, located on top of the gas tank, can be easily damaged during the installation of the hitch components. Care must be taken when positioning the front crossmember and center section components.

## **Warning**

On Short bed trucks, BEFORE INSTALLING THIS HITCH, check for adequate turning clearance between the front of all of your trailers and the truck cab.

## **Warning**

**DO NOT invert** the ball in the socket when carrying heavy loads on 2 wheel drive trucks. The ball may hit the top of the differential. Remove the ball from the socket before loading. A plug for the socket is available from B & W.

# **INSTALLATION INSTRUCTIONS**

## **STEP ONE**

Mark a 4" round hole on the topside of the truck bed floor. Center the hole between the wheel wells and **49 ½"** to the center of the hole from the back edge of the truck bed. Drill a small hole inside the marked area and cut out the circle using a saber saw with a metal cutting blade or a 4" hole saw.

## **STEP TWO**

Loosen, but do not remove, the passenger's side bed bolts. Remove all remaining bed bolts. (Loosen or remove running board or other equipment fasteners that would prevent lifting the truck bed off the frame.) Raise the driver's side of the truck bed approximately 4" by jacking against the truck bed floor in front of the wheel well. (Be cautious of fuel filler hoses and electrical wiring.)

## **STEP THREE**

With the latch pin mechanism on the driver's side, position the hitch receiver assembly across the top of the frame rails. Slowly lower the truck bed, aligning the hitch receiver tube that protrudes from the hitch receiver assembly to fit through the round 4" hole in the truck bed floor. Replace the bed bolts. Square the hitch receiver assembly across the frame. Check truck bed alignment with the cab, and tighten the bed bolts.

## **STEP FOUR**

Fastening the hitch receiver assembly to the truck frame requires drilling four 9/16" holes through the truck bed floor, hitch receiver assembly and truck frame rails. To locate the holes, mark a line, squared across the truck bed floor, through the center of the round hitch receiver tube. Mark the location on the line 15 ¾" from the center of the round hitch receiver tube on each side. (If these locations are in a raised corrugation in the truck bed floor, insert a metal shim of the correct thickness between the hitch receiver assembly and the truck bed floor in the raised corrugation.) Mark a hole location 3" above the line and 3" below the line at these locations. Verify that these locations are near the center of the frame rails, and carefully examine fuel lines, brake lines, and electrical wiring to assure adequate clearance. Mark, DOUBLE CHECK and center punch these hole locations. To maintain proper alignment use the following procedure, one hole at a time: First, drill a ¼" pilot hole, then drill a 9/16" hole through the pilot hole, and drop the bolt in the hole. When all holes have been drilled, use a flat washer, lock washer and tighten a nut on each bolt. Seat the square bolt shank of the bolts with several sharp hammer blows to the bolt heads. Finally, torque the fasteners to 90 ft. lbs.

## **STEP FIVE**

To install the safety chain brackets it is necessary to drill four ½" holes through the truck bed floor and the hitch receiver assembly. Mark a location on the line, squared across the truck bed floor, centered through the round hitch receiver tube 6 ¼" from the center of the round hitch receiver tube on each side. These locations should be in a low section of the corrugated bed floor. Mark a hole location 1" above the line and 1" below the line at these locations. Center punch these hole locations and drill ¼" pilot holes through the truck bed floor and hitch receiver assembly. Complete by drilling ½" holes through the pilot holes. Drop a safety chain bracket (U-bolt) through each pair of holes from the topside of the truck bed floor. Place a spring and lock nut on each of the four legs. Tighten the lock nuts until ¼" of threads extends through the lock nut.

## **STEP SIX**

Retract the latch pin by pulling the handle all the way out and sliding it to the left. Place the 2-5/16" ball in the hitch receiver. Engage the latch pin by moving the handle to the right and in. Be certain the latch pin passes through the hole and the 2-5/16" ball and fully engages through the hitch receiver. Repeat this process with the 2-5/16" ball in all eight positions. Grease the square base of the 2-5/16" ball.