



**NOTE:** *We recommend reading instructions before beginning the installation.*

**WARNING:** *The tow vehicle's towing capacities should under NO circumstances be exceeded.*

## Turnoverball™ Gooseneck Hitch Installation Instructions

# Model 1197R

**Ford (1997-2003) and 2004 Ford Heritage (Old body Style)  
1/2 Ton & Light 3/4 Ton, Short and Long Bed  
Light Duty Body Style**

**Except 1997 Ford w/ Air Bag Overloads**

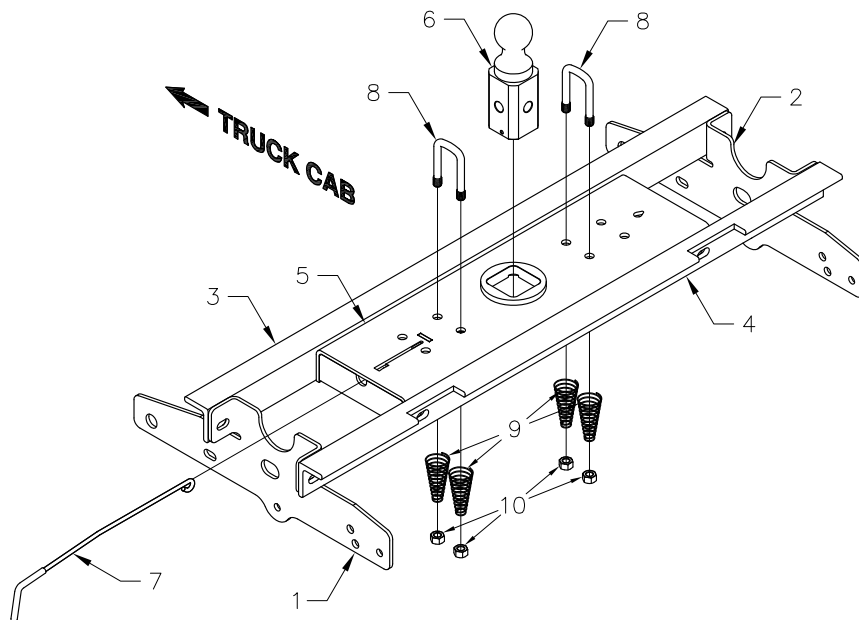

Mounting Kit Box (GNRM1197)		
ITEM	DESCRIPTION	QTY
1	Driver Side Plate	1
2	Passenger Side plate	1
3	Front Crossmember	1
4	Rear Crossmember	1

Mounting Kit Bolt Bag		
	7/16" X 1-1/2" Cap Screw	4
	7/16 Flat Washer	4
	7/16" Lock Washer	4
	7/16" Hex Nut	4
	1/2" X 1-1/2" Cap Screw	10
	1/2" Flat Washer	14
	1/2" Lock Washer	10
	1/2" Finish Nut	10
	7/8" X 2-1/2" Cap Screw	2
	7/8" Flat Washer	2
	7/8" Lock Washer	2
	7/8" Finish Nut	2

Center Box (GNRC800)		
ITEM	DESCRIPTION	QTY
5	Center Section	1
6	2-5/16" Ball	1
7	Latch pin Handle	1

Safety Chain Kit Bolt Bag		
8	1/2" U-Bolt	2
9	Conical Springs	4
10	1/2" Lock Nut	4
	5/16" X 3/4" Carriage Bolt	1
	5/16" X 3/4" Cap Screw	1
	5/16" Lock Nut	1

**NOTICE:** This product was designed to fit vehicles in their original, "as manufactured" condition. Compatibility with vehicles having replacement parts, or other modifications is not guaranteed. Inspect vehicle for modifications before installation of this product.

## **BEFORE INSTALLING**

### **OVERHEAD LIFTING DEVICE**

An overhead-lifting device, such as chain falls, engine hoist, or cable come-a-long, can be used to lift the center section of the hitch in place. Lower a loop of rope or chain through the 4" hole in the truck bed floor and attach it to the latch pin in the round hitch receiver tube in the center section. Use the lifting device to raise the center section until the round hitch receiver tube that protrudes from the center section fits in the 4" hole in the truck bed floor. Maintaining upward pressure may facilitate fastening the crossmember to the center section, especially if the truck bed floor has been distorted downward from heavy use. If you use an overhead-lifting device, it should be disconnected before squaring the center section across the frame, installing the sideplates and torquing fasteners.

### **WARNING**

Most trucks have FUEL LINES and/or BRAKE LINES and/or ELECTRICAL WIRES located along the frame rails where B&W Turnoverball™ hitches install. Carefully examine the location of fuel lines, brake lines and electrical wires BEFORE INSTALLATION. Be certain you will not damage fuel lines, brake lines or electrical wires when positioning hitch components, drilling holes, tightening fasteners, and lifting and lowering the truck bed. The fuel tank vent, located on top of the gas tank, can be easily damaged during the installation of the hitch components. Care must be taken when positioning the front crossmember and center section components. We recommend removing the bed bolts on the driver's side and lifting the bed to give you more clearance during installation of the hitch parts under the bed floor.

### **WARNING**

*ON SHORT BED TRUCKS, BEFORE INSTALLING THIS HITCH, CHECK FOR ADEQUATE TURNING CLEARANCE BETWEEN THE FRONT OF ALL OF YOUR TRAILERS AND THE TRUCK CAB.*

### **WARNING**

***DO NOT INVERT** THE BALL IN THE SOCKET WHEN CARRYING HEAVY LOADS ON 2 WHEEL DRIVE TRUCKS. THE BALL MAY HIT THE TOP OF THE DIFFERENTIAL. REMOVE THE BALL FROM THE SOCKET BEFORE LOADING. A PLUG FOR THE SOCKET IS AVAILABLE FROM B&W.*

## **INSTALLATION INSTRUCTIONS**

### **STEP ONE**

Mark a 4" round hole on the topside of the truck bed floor. Center the hole between the wheel wells and 46 1/2" to the center of the hole from the back edge of the truck bed (tail gate end). This will place the Turnoverball™ hitch about 6" forward of the truck axle center. Drill a small hole inside the area marked and cut out the round hole, using a 4" hole saw or use a saber saw and metal cutting blade.

### **STEP 2**

Select the rear crossmember that is notched on one side. With the long (2 1/2") side of the angle iron pointing down and the short (2") side with the notches facing the rear of the truck, position it across the top of the frame rails, between the bed and frame, by pushing it through the opening in the wheel well on the driver's side of the truck. Make certain that the notches fit tightly against the **truck bed** crossmember on the back of the truck. Select the second crossmember without notches and place it between the bed and frame, by pushing it through the opening in the wheel well on the driver's side of the truck. With the two crossmembers approximately parallel, position them about 9" apart, equally spaced in front and behind the hole in the truck bed floor and hanging over the same distance on each side of the frame rails.

### STEP 3

With the latch pin mechanism on the driver's side of the truck, raise the center section of the hitch into position between the crossmembers from beneath the truck. The round tube hitch receiver that protrudes from the center section must fit through the hole in the truck bed floor. Fasten the center section to the crossmembers, as shown in Fig. A, using the six 1/2" x 1 1/2" bolts. Start these bolts through the slots in the crossmember using a flat washer and lock washer on each bolt. Align the assembly with frame rails and tighten.

### STEP 4

Square the assembled center section and crossmembers across the frame. Install the sideplates on the outside of the frame rails by attaching the sideplates to the crossmembers using 1/2" x 1 1/2" bolts, flat washer, lock washer and nut. Do not fully tighten. Attach the sideplate to the frame utilizing 7/8" X 2 1/2" bolt and the 7/16" X 1 1/2" bolts provided in the mounting kit. Repeat steps on opposite side. On some frames it may be necessary to drill the 7/16" hole. Drill one of the 3 holes at the rear of the sideplate, taking care to avoid the fuel line, brake line and electrical wires located on the inside of the frame. With the crossmembers, center section and sideplates installed, torque all fasteners to 90 ft. lbs., in the following sequence. (Use caution not to damage the brake line or fuel line). First, torque the crossmembers to the center section. Second, torque the crossmembers to the sideplates. Third, torque the sideplates to the frame rails.

### STEP 5

To install the safety chain brackets it is necessary to drill four 1/2" holes through the truck bed floor. Drill the holes from beneath the truck, through the four holes furthest from the round hitch receiver tube in the center section. Drop a U-bolt through each pair of holes from the topside of the truck bed floor. Place a spring and lock nut on each of the four legs. Tighten the lock nuts until 1/4" of thread extends through the lock nut.

### STEP 6 – INSTALL LATCH PIN RELEASE HANDLE

**WARNING: LATCH PIN WILL NOT FUNCTION PROPERLY IF HANDLE IS NOT INSTALLED CORRECTLY.**

Install the latch pin release handle by inserting it through the slot in the end of the center section on the driver's side of the truck. Align the handle eyelet with the square hole in the latch pin so the handle is in line with the latch pin as shown. Secure the handle to the pin with the 5/16 X 3/4" carriage bolt and 5/16" locking flange nut as shown. Note: The included 5/16" cap screw can replace the carriage bolt if wrench access on the "cab side" of the handle is limited. Tighten the nut until it is secure. Do not over-tighten and deform the handle eyelet.

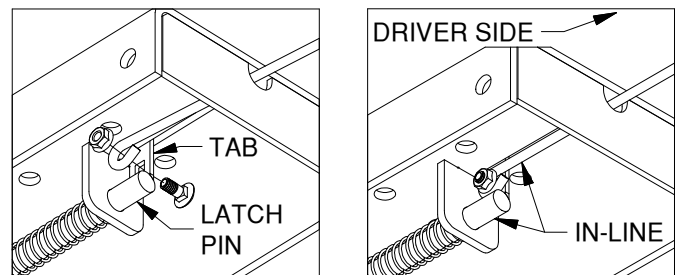

### STEP 7

Retract the latch pin by pulling the handle out until it stops and then rotating it slightly to the left. Place the 2-5/16" ball in the hitch receiver. Engage the latch pin by rotating the handle slightly to the right. Be certain the latch pin passes through the holes in the 2-5/16" ball and fully engages through both sides of the receiver tube. Repeat this process with the 2-5/16" ball in all four positions, both upright and inverted. Lightly lubricate the four corners of the hitch ball.