



NOTE: *We recommend reading instructions before beginning the installation.*

WARNING: *The tow vehicle's towing capacities should under NO circumstances be exceeded.*

Turnoverball™ Gooseneck Hitch Installation Instructions

Model 1108R

1999-2010 Ford 3/4 & 1 Ton
Super Duty Long and Short Bed Trucks
2008-2010 F-450 w/ Factory Installed Bed

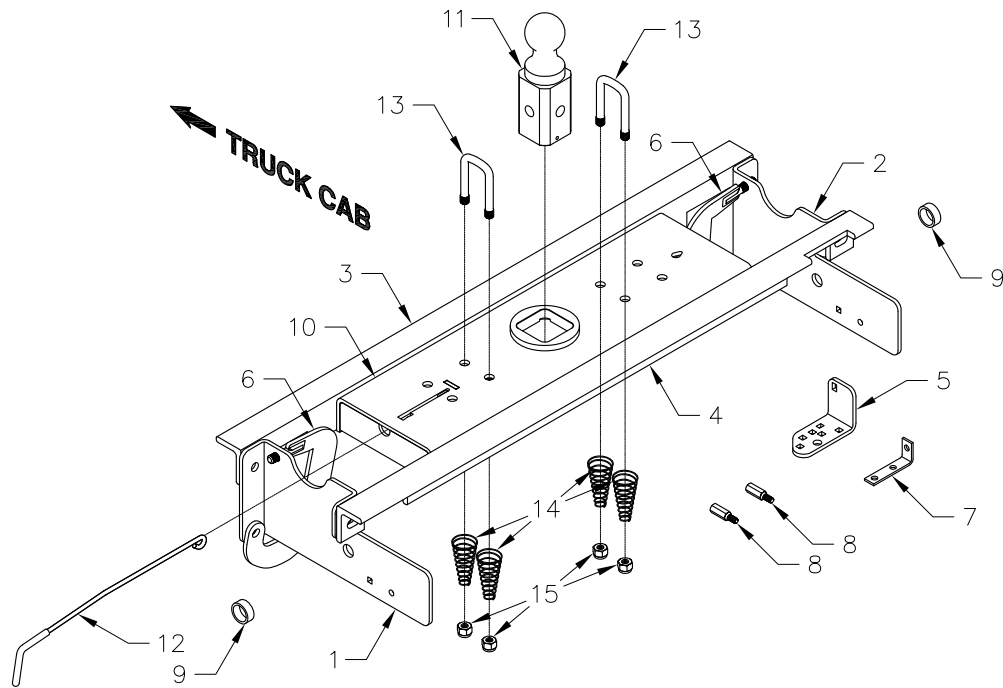

Mounting Kit Box (GNRM1108)

ITEM	DESCRIPTION	QTY
1	Driver Side Plate	1
2	Passenger Side plate	1
3	Front Crossmember	1
4	Rear Crossmember	1
5	Exhaust Bracket	1
6	Side Plate Clamp	2

Mounting Kit Bolt Bag

7	Fuel Line Bracket	1
8	Standoff Bolt	2
9	Pipe Spacer	2
	1/4" X 3/4" Carriage Bolt	1
	1/4" Flange Nut	1
	5/16" Carriage Bolt	3
	5/16" Flange Nut	3
	1/2" X 1-1/2" Cap Screw	12
	1/2" Flat Washer	10
	1/2" Lock Washer	14
	1/2" Finish Nut	14
	3/4" X 2-1/2" Cap Screw	2
	3/4" Flat Washer	2
	3/4" Lock Washer	2
	3/4" Finish Nut	2

Center Box (GNRC800)

ITEM	DESCRIPTION	QTY
10	Center Section	1
11	2-5/16" Ball	1
12	Latch pin Handle	1

Safety Chain Kit Bolt Bag

13	1/2" U-Bolt	2
14	Conical Springs	4
15	1/2" Lock Nut	4
	5/16" X 3/4" Carriage Bolt	1
	5/16" X 3/4" Cap Screw	1
	5/16" Lock Nut	1

NOTICE: This product was designed to fit vehicles in their original, "as manufactured" condition. Compatibility with vehicles having replacement parts, or other modifications is not guaranteed. Inspect vehicle for modifications before installation of this product.

BEFORE INSTALLING- OVERHEAD LIFTING DEVICE

An overhead-lifting device, such as chain falls, engine hoist, or cable come-a-long, can be used to lift the center section of the hitch in place. Lower a loop of rope or chain through the 4" hole in the truck bed floor and attach it to the latch pin in the round hitch receiver tube in the center section. Use the lifting device to raise the center section until the round hitch receiver tube that protrudes from the center section fits in the 4" hole in the truck bed floor. Maintaining upward pressure may facilitate fastening the crossmember to the center section, especially if the truck bed floor has been distorted downward from heavy use. If you use an overhead-lifting device, it should be disconnected before squaring the center section across the frame, installing the sideplates and torquing fasteners.

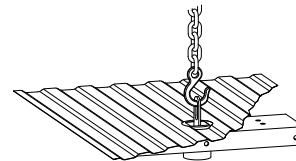

WARNING

Most trucks have FUEL LINES and/or BRAKE LINES and/or ELECTRICAL WIRES located along the frame rails where B&W Turnoverball™ hitches install. Carefully examine the location of fuel lines, brake lines and electrical wires BEFORE INSTALLATION. Be certain you will not damage fuel lines, brake lines or electrical wires when positioning hitch components, drilling holes, tightening fasteners, and lifting and lowering the truck bed. The fuel tank vent, located on top of the gas tank, can be easily damaged during the installation of the hitch components. Care must be taken when positioning the front crossmember and center section components.

WARNING

On Short bed trucks, BEFORE INSTALLING THIS HITCH, check for adequate turning clearance between the front of all of your trailers and the truck cab.

WARNING

DO NOT invert the ball in the socket when carrying heavy loads on 2 wheel drive trucks. The ball may hit the top of the differential. Remove the ball from the socket before loading. A plug for the socket is available from B & W.

INSTALLATION INSTRUCTIONS

4" BALL LOCATION:

8' LONG BED AND SHORT BED (BED LESS THAN 8' LONG) = 47"

REMOVE SPARE TIRE BEFORE INSTALLING HITCH.

*****SAFETY NOTICE*** On 2008 and newer trucks we recommend removing the spare tire heat shield to avoid injury.**

STEP 1 – MARKING AND CUTTING 4 INCH HOLE IN TRUCK BED

Begin by measuring for the correct hole location in the truck bed floor. Measure from the tail gate end of the truck bed floor by hooking a tape measure over the end of the truck box and mark the floor at 47". Next find the center point between the wheel wells, where these marks intersect with the first measurement will be the center point of your four inch hole. This Location is critical to the correct installation of the B & W Turnoverball™ so measure, mark and saw carefully. Make a four inch hole at this location. B&W recommends using a four inch hole saw, however the hole can be cut by other means. If your truck has a spray-in bed liner you will need to take into account when you are measuring to add the thickness of the applied liner that has been sprayed over the end of the bed. If your truck has a Drop-in plastic bed liner, you may saw through both, but it is more difficult to accurately locate the midpoint between the fender wheel wells, and to be sure that the bed liner does not move when sawing the hole. Once you have the four inch hole in the bed use a deburring tool or a die grinder and carefully remove the burr from the under side of the bed around the hole.

STEP 2 – HEAT SHIELD REMOVAL

Remove the heat shield located above the rear axle under the truck bed.

STEP 3 – BRAKE CABLE & FUEL LINE BRACKET

On **2004 and older** trucks the emergency brake cable located on the outside of the driver's side frame will have to be relocated. Knock the mounting stud out of the frame and discard. A relocating bolt is furnished in the kit and will be installed later.

On trucks equipped with a gasoline engine it may be necessary to relocate a fuel line bracket. If the oval hole in the driver's side frame just above the axle is partially blocked you will need to relocate the bracket. This bracket may be held by a nut and stud on the outside of the frame or by a plastic retainer pushed through the frame from the inside. Remove the nut or push the plastic retainer through the frame so the bracket can be rotated 90 degrees. Next install the relocation bracket supplied in the kit. Using a 5/16" carriage bolt and flange nut bolt the bracket to the inside of the frame as shown in the diagram. The factory fuel line bracket can now be reinstalled on the relocation bracket. If there is a threaded stud on the bracket, Place the stud through the outer hole and fasten with the nut removed earlier. If the bracket has a plastic retainer, push it through the inner hole in the relocation bracket.

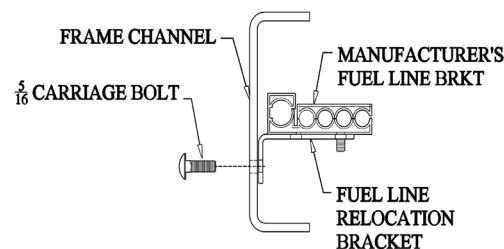

END VIEW OF FRAME CHANNEL FROM DRIVER'S

STEP 4 – EXHAUST BRACKET REMOVAL

On 2005 and newer trucks equipped with a diesel engine the tail pipe will need to be lowered. First remove the tail pipe bracket just behind the rear tire on the passenger side. This will be reattached later.

STEP 5 – BED FLANGE MODIFICATION

Some models of trucks will allow the crossmembers to slide between the frame and bed without modification. If this is not possible a small notch needs to be made in the flange on the driver's side of the truck. (see diagram)

Locate the front truck bed cross member in the wheel well. Measure from the back of the cross member and make a mark at 1 1/2" this measurement is important. This will be the center point for the notch that is needed. Mark and cut a 7/8" wide by 3/8" tall notch.

BED FLOOR FLANGE IN DRIVER'S SIDE WHEEL WELL

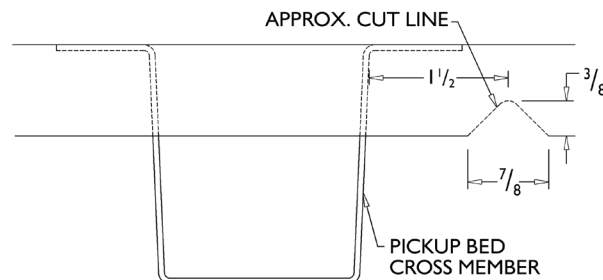

STEP 6 – CROSS MEMBER INSTALLATION

The 1108 mounting kit is supplied with two angle crossmembers. The rear crossmember has three notches and will be installed first. Slide the rear crossmember between the frame and bed on the driver's side. If necessary use the notch cut into the bed flange in step 5. Make certain the leg of the angle with the oval holes is facing toward the cab. After sliding the angle in about half way it may need to be guided onto the other frame from the underside of the truck. At this point the angle should span between both frame rails and in front of the shock bracket on the passenger side. Next using the notch over the shock bracket for clearance, roll the angle iron over the bracket while sliding it toward the rear. **It is important to hold the driver's side of the crossmember upward against the bed floor and forward against the bed crossmember.** Continue to slide it back until it is about four inches behind the four inch hole that has been drilled in the bed. Next install the front angle in the same manor except for the leg of the angle with the oval holes should face the rear of the truck during installation. Slide it rearward just behind the shock bracket and leave until needed for installation. When installed correctly the two angle legs with the holes should be facing each other.



***** HAND TIGHTEN ALL HARDWARE IN STEPS 7 AND 8 *****

STEP 7 – INSTALL CLAMPING STRAP & SIDE PLATES

If the emergency brake cable has been removed from the frame, place a 5/16" carriage bolt (included) through the small square hole in the driver side sideplate, add a 5/16" nut loosely to hold in place. This will be used for attaching the emergency brake cable bracket. Next you will need to install the clamping strap and side plate on the driver side of the truck. Take a side plate clamp and position around the frame approximately 6 1/2" in front of the slotted hole on the side of the frame. Next take the driver side sideplate and slide the bottom side of the sideplate between the clamping strap and the frame (see picture). Guide the stud on the clamping strap through the hole in the top of the sideplate place a 1/2" lock washer and nut on the stud. Next place a 1/2" bolt through the hole in the bottom of the clamping strap and the sideplate and add a 1/2" lock washer and nut. Next install a pipe spacer between the side plate and the frame and place the 3/4" bolt through the sideplate, pipe spacer, and the frame then add a 3/4" flat washer, lock washer and nut. Repeat the process for the passenger side.



STEP 8 – INSTALL THE CENTER SECTION

Raise the center section into position between the cross members from beneath the truck, with the latch pin release handle on the driver side. A lifting device, as described on page 1 will help. The round hitch receiver that protrudes from the top of the center section must fit through the hole in the truck bed floor. Slide the angles against the center section (an adjustable wrench can be used to stand the angles up if needed) and bolt together using six 1/2" x 1 1/2" bolts. Place the bolts with a flat washer through the slots in the cross member and through the holes in the center section and add a 1/2" lock washer and nut. Next bolt the side plates to the angle cross members using a 1/2" x 1 1/2" bolt through the side plate, through the angle and add a 1/2" flat washer, lock washer and nut.

STEP 9 – TIGHTEN HARDWARE

1. Tighten the center section to cross member bolts to 80 ft pounds. 2. Check to ensure the assembled center section is square with the frame. 3. Tighten the 3/4" side plate bolts to 120 ft pounds. 4. Tighten the bottom clamping strap bolts to side plate to 80 ft pounds. 5. Tighten the clamping strap studs to 60 ft pounds. 6. Tighten the side plate to angle bolts 80 ft pounds. If the emergency brake cable has been removed, take the 5/16" nut off the previously installed bolt. Place the emergency brake cable bracket over the bolt, replace the nut and tighten.

STEP 10 – INSTALL LATCH PIN RELEASE HANDLE

WARNING: LATCH PIN WILL NOT FUNCTION PROPERLY IF HANDLE IS NOT INSTALLED CORRECTLY.

Install the latch pin release handle by inserting it through the slot in the end of the center section on the driver's side of the truck. Align the handle eyelet with the square hole in the latch pin so the handle is in line with the latch pin as shown. Secure the handle to the pin with the 5/16 X 3/4" carriage bolt and 5/16" locking flange nut as shown. Note: The included 5/16" cap screw can replace the carriage bolt if wrench access on the "cab side" of the handle is limited. Tighten the nut until it is secure. Do not over-tighten and deform the handle eyelet.

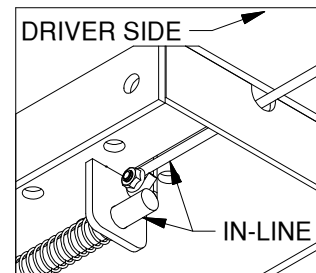
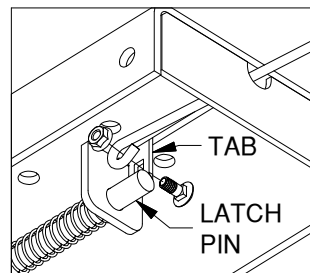

STEP 11 – INSTALL SAFETY CHAIN U-BOLTS

To install the safety chain U-bolts it is necessary to drill four ½" holes through the truck bed floor. Drill the holes from beneath the truck, through the two holes located on each side and closest to the round receiver tube in the center section. This will locate the safety chain U-bolt in the lowest point of the floor corrugation. After you drill the four holes clean the burrs from around the holes in the top of the bed then drop a U-bolt through each pair of holes. Place a spring and lock nut on each of the four legs. Tighten the nuts until flush with the bottom of the U-bolts.



STEP 12 – RE-ATTACH EXHAUST

On 2005 to present pickups equipped with a diesel engine, the exhaust will have to be lowered to allow clearance for the Turnoverball™ Hitch.

2005 to 2007 Model Trucks

On 2005 through 2007 Ford Super Duty Trucks with a diesel engine, the exhaust will have to be lowered at the rear exhaust bracket to allow clearance for the Turnoverball™ Gooseneck Hitch. See Diagrams 12A, 12B and 12C.

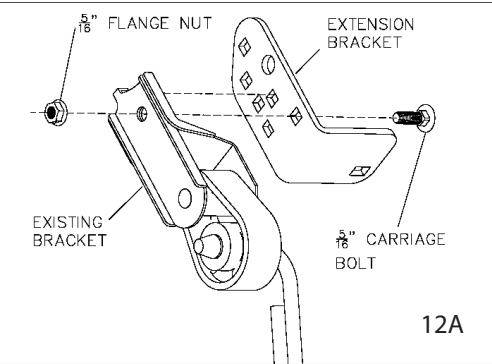

12A

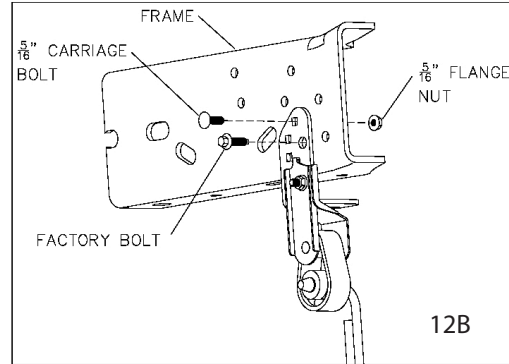

12B

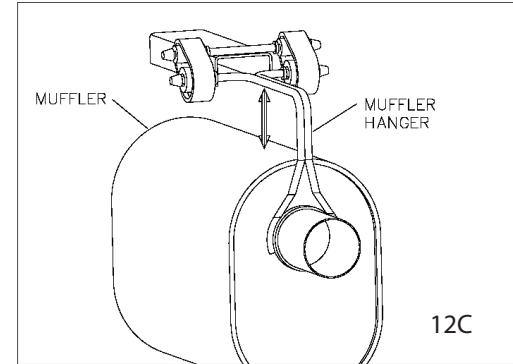

12C

Attach the supplied extension bracket to the existing tail pipe bracket.

Attach the new bracket to the frame.

If more clearance is needed, pry between muffler and hanger to increase the distance between the two.

2008 to Present

On 2008 and newer Ford Super Duty Trucks with a diesel engine, the exhaust will have to be lowered at the rear exhaust bracket and can be lowered at the front exhaust bracket if needed to ease installation, allow adequate clearance for the exhaust and improve ground clearance at the end of the tail pipe. See Diagrams 12D, 12E, 12F.

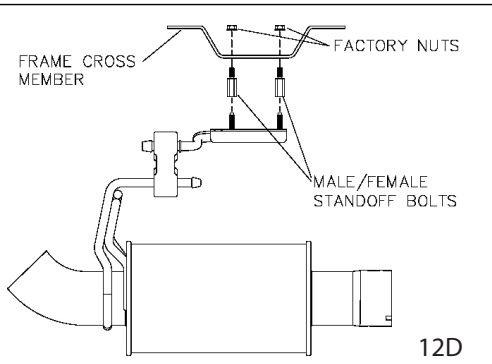

12D

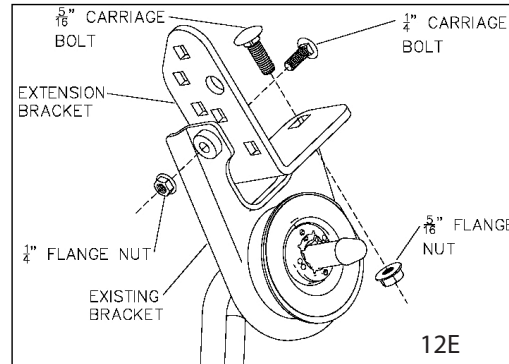

12E

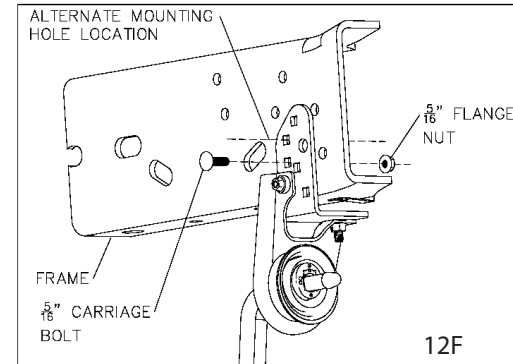

12F

Remove the nuts holding the exhaust bracket to the frame cross member just in front of the axle. Next thread the standoff bolts onto the bolts that are pressed into the bracket until the standoffs "bottom out." The two standoffs must be equal distance from the top of the bracket. Secure bracket to cross member with standoffs and factory nuts.

Attach the supplied extension bracket to the existing tail pipe bracket.

Attach the supplied extension bracket to the frame, using the same hole used by the factory bracket, as shown. If additional clearance is needed, mount the bracket to the frame using alternate mounting hole in the supplied bracket as shown.

STEP 13 - RE-ENGAGE LATCH PIN HANDLE

Retract the latch pin by pulling the handle all the way out until it stops and then rotate it clockwise. Place the 2-5/16" Ball in the hitch receiver. Engage the latch pin by rotating the handle counterclockwise. Be certain the latch pin passes through the holes in the 2-5/16" Ball and fully engages through the hitch receiver. Remove and grease the square base of the 2-5/16" Ball.

STEP 14 - Reinstall the spare tire heat shield and spare tire.