



## B&W Trailer Hitches

# Turnoverball® Gooseneck Hitch Installation Instructions

## MODEL 1217

2017 - 2018 Nissan Titan XD Model S Trucks

Mounting Kit Box (GNRK1217)		
ITEM	DESCRIPTION	QTY
1	Driver Side Plate	1
2	Passenger Side Plate	1
3	Front Cross Member	1
4	Front Cross Member Brace	1
5	Rear Cross Member	1
6	Driver Side Pin Bracket	1
7	Passenger Side Pin Bracket	1
8	1/2" X 48" Fish Wire	4

Center Box (GNRC1219)		
ITEM	DESCRIPTION	QTY
12	Center Assembly	1
13	2-5/16" Ball	1
14	Latch Pin Handle	1

Safety Chain Kit Bolt Bag		
ITEM	DESCRIPTION	QTY
15	1/2" U-Bolt	2
16	Conical Springs	4
17	1/2" Lock Nut	4
	5/16" X 3/4" Cap Screw	1
	5/16" X 3/4" Carriage Bolt	1
	5/16" Flange Nut	1

Mounting Kit Bolt Bag		
ITEM	DESCRIPTION	QTY
9	Bolt Guide Assembly	2
10	Bolt Retainer	2
11	Locking Strap	2
	O-Ring	2
	1/2" X 1-1/2" Cap Screw	8
	1/2" X 1-1/2" Carriage Bolt	2
	1/2" X 2" Carriage Bolt	6
	1/2" Flat Washer	10
	1/2" Lock Washer	16
	1/2" Finish Nut	16
	5/8" X 4-1/2" Cap Screw	2
	5/8" Flat Washer	2
	5/8" Lock Washer	2
	5/8" Flange Nut	2
	5/8" Finish Nut	2

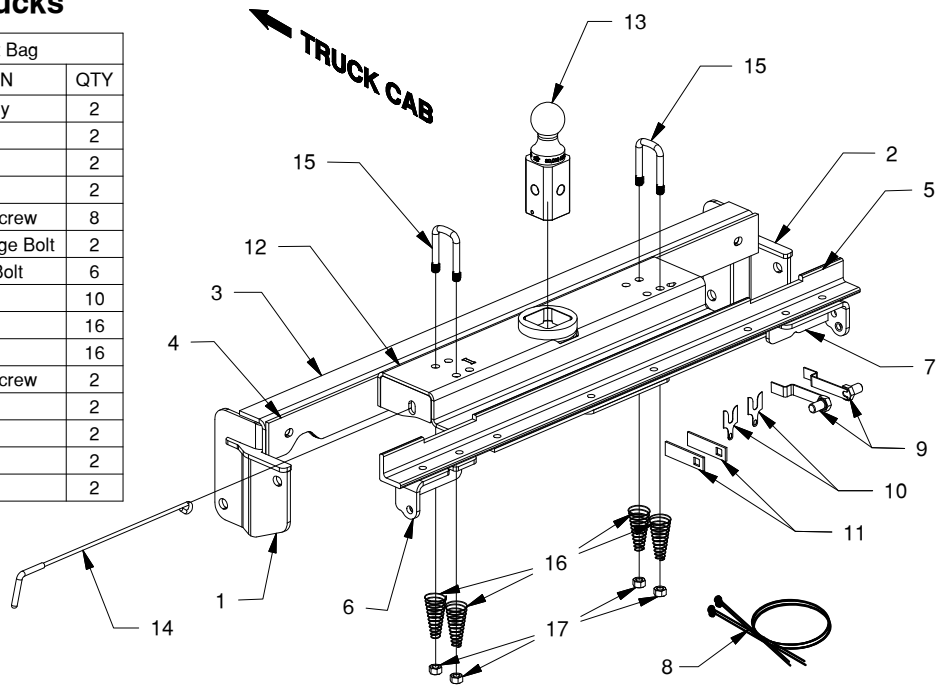

### ⚠️ WARNING

Failure to comply with the safety information in these instructions could result in serious injury or death.

- ⚠️ Read all installation and operating instructions along with all labels before using this product.
- ⚠️ Adding components such as a Turnoverball hitch to the chassis of any vehicle can be hazardous. There is potential for unexpected combustion of fuel, electric shock, burns, shifting or falling of unstable vehicle, damage to vehicle, injury from tool usage and many other hazards. This installation must be completed by someone who is aware of the hazards involved. This person must be knowledgeable of proper safety procedures for a vehicle modification of this nature, and for usage of the equipment required to perform the installation.
- ⚠️ Without proper knowledge, towing can be a dangerous activity. Understand all the risks involved with towing before proceeding. For information on towing safety, see "**The Trailer Handbook: A Guide to Understanding Trailer and Towing Safety**" from the National Association of Trailer Manufacturers, and your trailer manufacturer's owner's manual.
- ⚠️ Do not exceed tow or tongue rating of coupler, tow or tongue rating of hitch, or tow or weight ratings of truck or trailer. See vehicle and trailer manufacturer information for ratings. Exceeding these ratings may cause damage to towing components or loss of attachment between the trailer and truck.
- ⚠️ Additional caution must be used when towing a wedge car trailer. Towing stability greatly depends on keeping the center of gravity as low as possible. Load heavy cars over the axles. Never tow with a single car on the front of the trailer. When towing a wedge car trailer, never exceed speeds that are reasonable for the roadway conditions (e.g. turns, going around a curve, etc.). Failure to account for proper trailer center of gravity and speeds that are reasonable for the roadway conditions may cause damage to the truck, trailer, towing components, and loss of attachment between the truck and trailer.
- ⚠️ This product was designed to fit vehicles in their original, "as manufactured" condition. Compatibility with vehicles having replacement parts, or other modifications is not guaranteed. Inspect vehicle for modifications before installation of this product.
- ⚠️ The Turnoverball hitch comes equipped with a 2-5/16" ball. Trailers towed with the ball provided must have a 2-5/16" coupler. Towing with a larger coupler could cause loss of attachment between the trailer and the tow vehicle.
- ⚠️ Do not modify this product in any manner. Doing so could alter its integrity and lead to a loss of attachment between the trailer and the tow vehicle.
- ⚠️ Do not invert the ball in the socket when carrying heavy loads on 2 wheel drive trucks. The ball may hit the top of the differential. Remove the ball from the socket before loading. A plug for the socket is available from B&W.

# PREPARE TO INSTALL

**NOTE:** Remove all parts from the packaging and familiarize yourself with all the parts and tools required. Use the parts list on the front page to verify that all parts and hardware are present.

Installation of the Turnoverball hitch requires several common tools and a few specialized tools. Below is a listing of equipment used during a typical installation.

## TOOLS REQUIRED

- Impact wrench or ratchet with 1/2", 3/4", & 15/16" sockets
- 1/2", 3/4", & 15/16" Box end wrench
- Marking tool (pencil or permanent marker)
- 4" Hole saw
- Drill with 1/2" bit
- Ear protection
- Lifting device
- Pilot hole drill bit
- Flashlight
- Eye protection
- Torque wrench
- Tape measure
- Pry bar

1. **Determine cab clearance.** The Turnoverball hitch is designed so that the ball can be inverted and stored below the surface of the truck bed while not in use. The ball location is determined by this design feature and the truck geometry. Measure the trailers to be towed with this hitch to be sure that the location of the 2-5/16" ball listed in step 5 will provide ample turning clearance between the nose of the trailers and the cab of the truck.

**⚠ Cab clearance on short bed trucks is very limited when towing certain trailers. Failure to ensure that there will be adequate clearance, may result in significant property damage, or serious injury.**

2. **Remove the spare tire (optional).** Following the vehicle manufacturer's instructions, remove the spare tire. This will provide easier access to the area where the hitch will be installed.
3. **Position the vehicle.** Installation of the hitch requires the installer to be under the truck bed in the area of the rear axle. Lifting the vehicle makes this area more accessible to the installer, and improves the installation process.

**⚠ Lift vehicle using only equipment designed for lifting and positioning vehicles for service. Failure to do so may result in property damage, serious injury, or death.**

4. **Prepare a lifting device (optional).** The purpose of the device is to safely hold the hitch in position during part of the installation, see Figure A1 for an example. A simple mechanical lifting device is available for purchase from B&W.

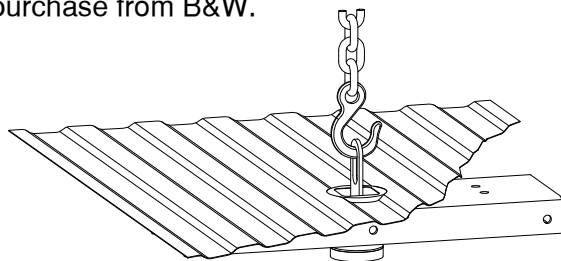

Figure A1

5. **Detach fuel valve canister, if needed.** Locate the rectangle shaped fuel valve canister. The canister will need to be lowered during the installation. First remove the three small bolts that hold the canister bracket to the truck using a 10mm wrench. Then slide the canister toward the center of the truck far enough to allow the end toward the frame to be pulled downward, see Figure A2. Then slide the canister back toward the frame to allow the complete canister to drop down about 4 to 5 inches providing space for installation, see Figure A3. The canister will be re-attached in a later step.

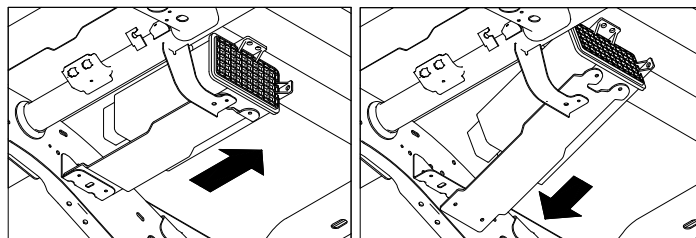

Figure A2: Looking up under the bed.

Figure A3

6. **Mark the 4" hole location.** Using a tape measure hooked over the rear edge of the bed (at tailgate end), measure the location for the hole as shown in Figure A2. Next, locate the center of the bed by measuring the distance between the wheel wells and dividing by two. The center of the hole will be at the intersection of the center of the bed and the first distance measured.

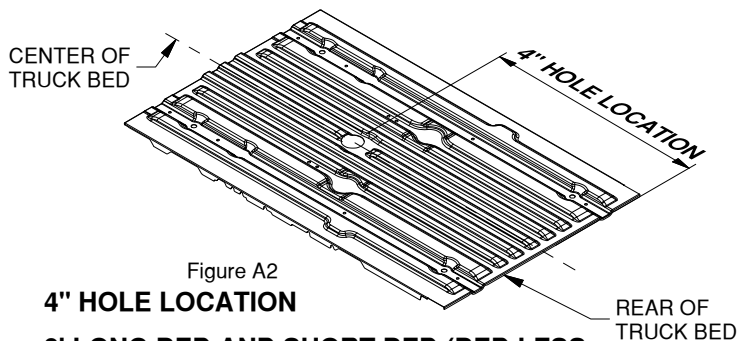

Figure A2

4" HOLE LOCATION

8' LONG BED AND SHORT BED (BED LESS THAN 8' LONG) - 46-1/2"

**IMPORTANT:** The hitch is designed to install only at the described location. Failure to place the 4" hole precisely may result in added difficulty during installation or property damage.

**IMPORTANT:** If your truck has a spray-in bed liner, you will need to take this into account when you are measuring, and add the thickness of the applied liner that has been sprayed over the end of the bed.

**IMPORTANT:** If the bed is equipped with a plastic bed liner, the hole may be cut through both the liner and the bed. However, the center of truck bed may be more difficult to locate, and the mark may be harder to hit if the liner slides or moves. Failure to cut the hole in the correct location may adversely affect the install and may result in property damage.

7. **Cut the 4" diameter hole.** Cut the hole in the marked location using a 4" hole saw or by marking out the 4" hole and using a saber saw equipped with a metal cutting blade. Remove any burrs created while cutting hole.
8. **Modify bed flange.** Cut two small notches in the bed flange just above the frame in the driver side wheel well, as shown in Figure A3. These notches are required for installing the hitch's rear cross member.

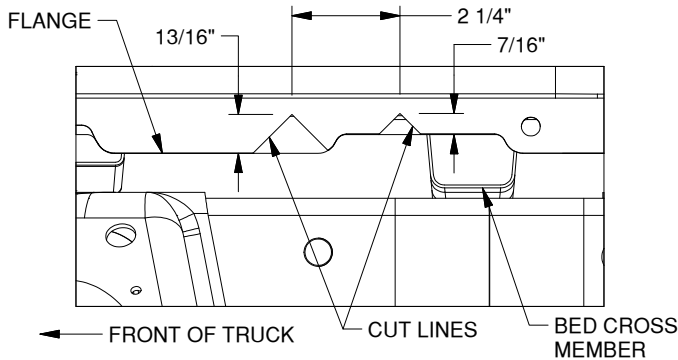

Figure A3: Looking at driver side wheel well.

9. **Temporarily remove vent hose.** Remove the vent hose that is installed into a hole on the inside of the passenger side frame rail just behind the rear axle, see Figure A4. This hose will be replaced at the end of the install.

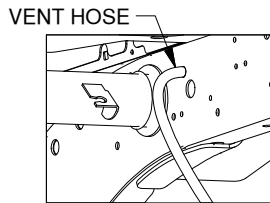

Figure A4

10. **Temporarily remove wiring connector.** For additional clearance, the wiring connector attached to the round frame cross member can be uninstalled from its bracket and allowed to hang during installation, see Figure A5. This will increase the clearance for the installation of the center section and protect the wiring connector during the install.

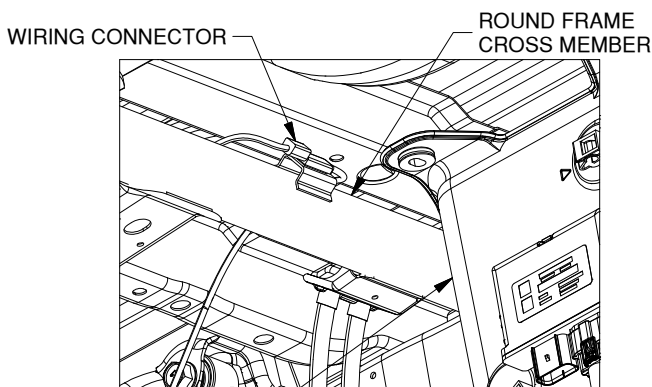

Figure A5

11. **Remove or modify fender liners as needed.** Some vehicles are equipped with various designs of plastic liners inside the rear wheel wells. If liners prevent installation they may be temporarily removed.

## INSTALL REAR CROSS MEMBER MOUNTING BRACKETS

- ⚠ Turnoverball hitch components are heavy and may be cumbersome to handle. Failure to use proper lifting techniques and caution when handling these items could result in serious injury.
- ⚠ Most trucks have fuel lines, brake lines, electrical wires or other vehicle systems located along the frame rails or in the general area where B&W Turnoverball hitches install. Carefully examine the locations of these systems before installation. Make certain that these are not damaged during positioning hitch components, drilling holes, or tightening fasteners. Damage to these systems may result in property damage, serious injury, or death.

**NOTE:** Install hardware so it is snug, but do not fully tighten hardware connections at this time.

1. **Prepare for mounting bracket installation.** Locate the rear cross member mounting brackets, two fish wires, the locking straps, the 1/2" x 1-1/2" carriage bolts, the O-rings, two 1/2" lock washers, and two 1/2" finish nuts. Identify the 3/4" hole on the inside of the frame rails behind the rear axle where the brackets will mount, and the larger hole in the frame ahead of the axle, see Figure B1.
2. **Thread fish wire through frame.** Insert the coil end of the fish wire into the 3/4" hole and fish it through the frame towards the front of the truck and out the larger hole as shown. Make sure the fish wire goes under the round frame cross member that goes through the inside wall of the frame. If the fish wire does not stay under the round cross member the hardware could get stuck inside the frame and not be able to be retrieved.

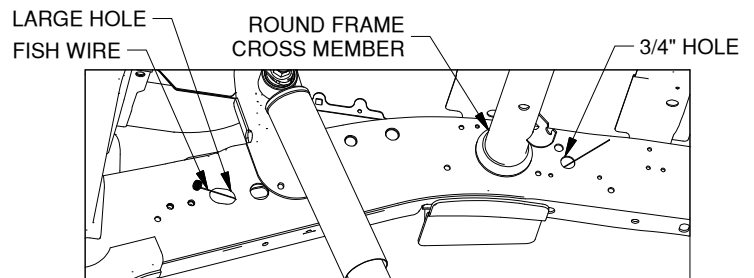

Figure B1: Looking at inside of frame rail.

- 3. Prepare hardware.** Thread the locking strap on the fish wire and attach the coil end of the fish wire to the carriage bolt, as shown in Figure B2. To keep the hardware from getting hung up inside the frame, the locking strap and the bolt need to go through the frame separated, as shown, and not with the bolt through the square hole in the strap.

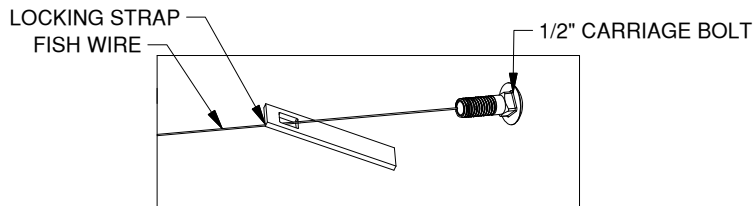

Figure B2

- 4. Pull fish wire through frame.** With the fish wire through the locking strap push the locking strap completely into the frame. Next, pull the carriage bolt into the frame. Continue pulling on the fish wire until the threaded portion of the bolt is sticking out of the frame. Thread the mounting bracket and an O-ring over the fish wire and onto the bolt. Push the O-ring tight against the bracket, see Figure B3. This will prevent the bolt from accidentally falling back into the frame. The O-ring will stay on the bolt after the washer and nut are installed and tightened.

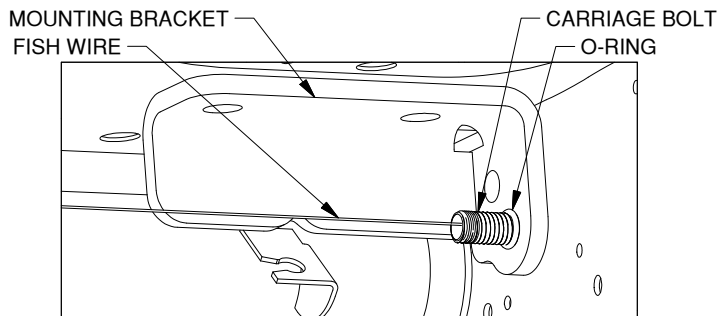

Figure B3: Looking at mounting bracket installation.

- 5. Secure hardware.** Remove the fish wire from the carriage bolt and secure the bolt with a lock washer and finish nut.
- 6. Repeat these steps for other side to install the second bracket.**

## INSTALL REAR CROSS MEMBER

- 1. Place rear cross member.** Locate the rear cross member and the area where the V-shaped notches were cut. Orient the rear cross member so the leg with the rectangular notches is toward the front of the truck. Slide the rear cross member through the V-shaped notches and between the bed and the frame until it spans the driver and passenger frame rails, as shown in Figure C1. Rotate the rear cross member so the leg with the rectangular notches is vertical. The leg with the holes should be flat against the top of the frame toward the rear of the truck.

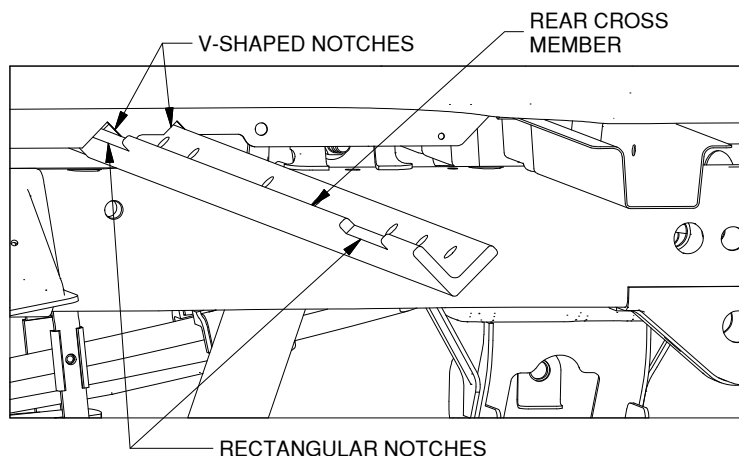

Figure C1: Looking into driver side wheel well.

- 2. Reposition cross member.** Slide the cross member toward the rear of the truck to provide room for installing the center section.

## INSTALL CENTER SECTION

- 1. Maneuver center section into place.** Locate the center section. With the raised portion of the center section up and the latch pin toward the rear of the truck, lift the center over the differential from the rear. Continue moving center section over the differential and toward the passenger side in front of the downturn in the exhaust pipe, see Figure D1. Rotate the center section and lift the latch pin side over the fuel tank so that the center section is perpendicular to the centerline of the truck, see Figure D2.

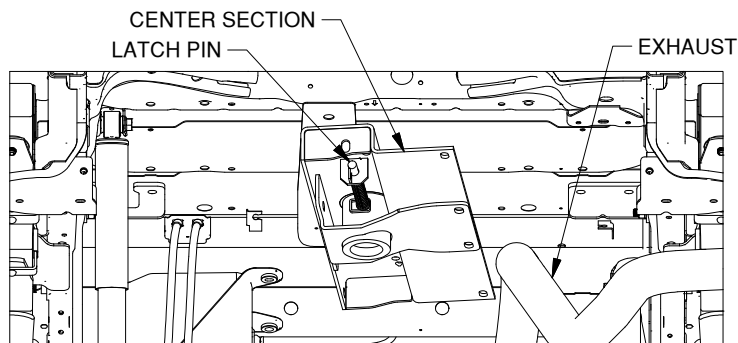

Figure D1: Looking up under truck bed (towards cab)

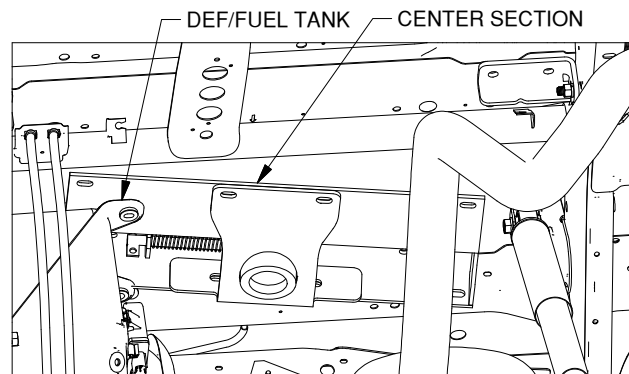

Figure D2: Looking up under truck bed (over differential)

- 2. Position center section.** Move the center toward the rear of the truck by passing the horizontal flange of the center section between the round frame cross member and the bed cross member directly above it. The raised portion of the center section should be under the 4" hole cut into the bed, see Figure D3.

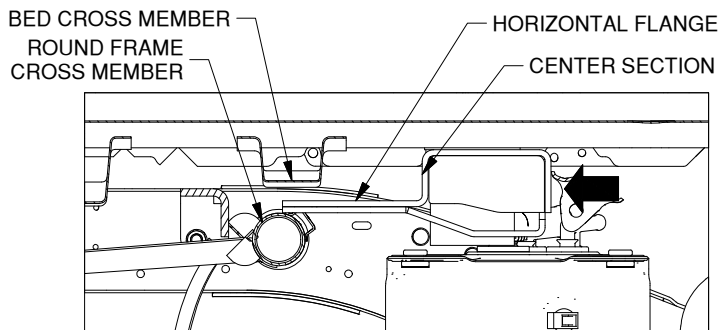

Figure D3: Cutaway view looking at center section from passenger side.

- 3. Attach lifting device (optional).** If using an overhead lifting device connect it to the latch pin of the center section at this time. However, do not pull it tight against the bed yet. Allow the front of the center to hang about 2-1/2" below the bed.

## INSTALL FRONT CROSS MEMBER

- 1. Place front cross member.** Locate the front cross member and position it on the passenger side of the truck, see Figure E1. The cross member will resemble an upside down "V". The flange with the holes will be toward the rear of the truck. Slide the front cross member between the bed and the frame in front of the center section until it spans the driver and passenger frame rails. Move cross member towards the front of the truck to make room to install the front cross member brace.

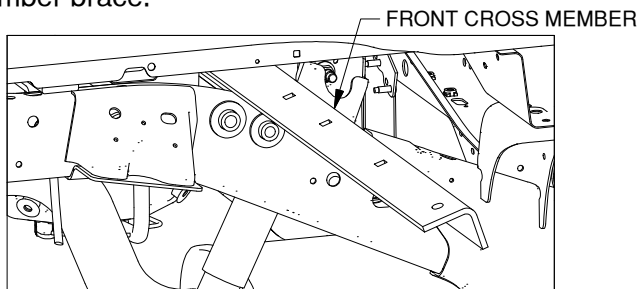

Figure E1: Looking into passenger side wheel well.

## INSTALL FRONT CROSS MEMBER BRACE

- 1. Place front cross member brace.** Locate the front cross member brace. From the passenger side, insert the brace between the bed and frame of the truck in front of the center section, as shown in Figure F1, until it spans the driver and passenger frame rails. The end with the notch will go in first so that it matches up with the notch in the front cross member.

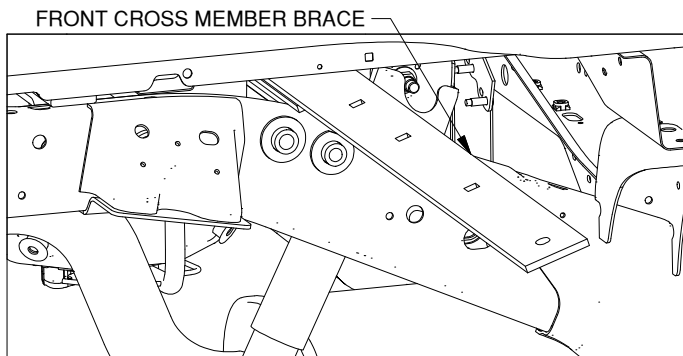

Figure F1: Looking into passenger side wheel well.

## ATTACH CROSS MEMBERS TO CENTER SECTION

**NOTE:** Install hardware so it is snug, but do not fully tighten hardware connections at this time.

- 1. Position the center section.** Lift the center section up against the bottom of the truck bed so that the raised portion of the center goes through the 4" hole in the bed.
- 2. Attach rear cross member.** Position the rear cross member so that the holes in its horizontal flange line up with the holes in the cross member brackets, and the holes in the horizontal flange of the center section. Attach these four parts together using the 1/2" x 1-1/2" long bolts, flat washers, lock washers, and nuts, as shown in Figure G1.

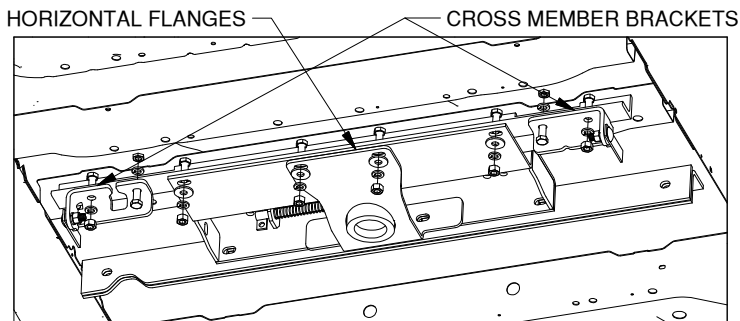

Figure G1: Looking up under truck bed (frame not shown).

- 3. Attach front cross members.** Slide the front cross member brace and the front cross member rearward against the center section. Line up the square holes in the cross members with the slots in the center section. Secure the cross member parts to the center section using the 1/2" x 2" carriage bolts, flat washers, lock washers, and nuts, as shown in Figure G2.

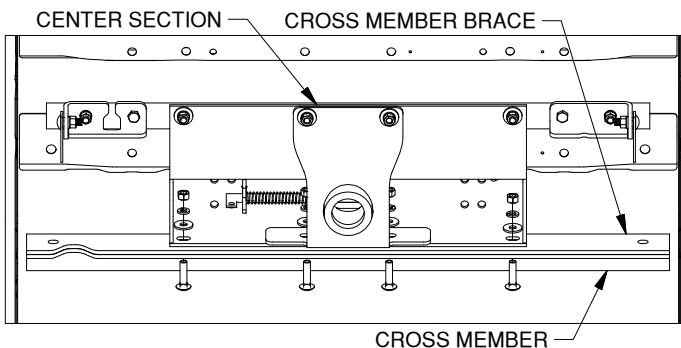

Figure G2: Looking up under truck bed (frame not shown). **PAGE 5 of 8**

# INSTALL SIDE PLATES

**NOTE:** Install hardware so it is snug, but do not fully tighten hardware connections at this time.

1. **Locate hardware for side plate installation.** Locate the driver and passenger side plates, the 5/8" bolt guide assemblies, the bolt retainers, the other 5/8" hardware, and fish wires.
2. **Place side plate onto frame.** Insert a 5/8" x 4-1/2" cap screw into the frame from the inside of the frame rail as shown in Figure H1. The threaded end of the cap screw should be flush with the outside wall of the frame. Position the driver side plate so that the ear is on top and pointing toward the frame in the driver side rear wheel well. With the ear tipped toward the truck lift the side plate into place, as shown in Figure H2.

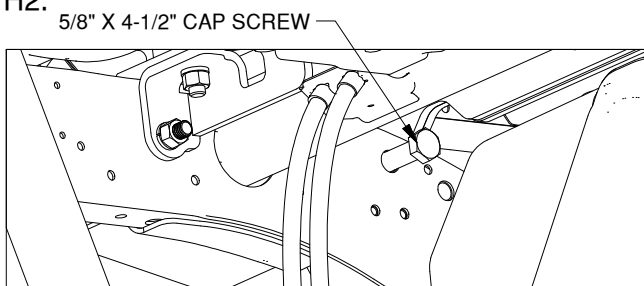

Figure H1: Looking at inside of driver side frame.

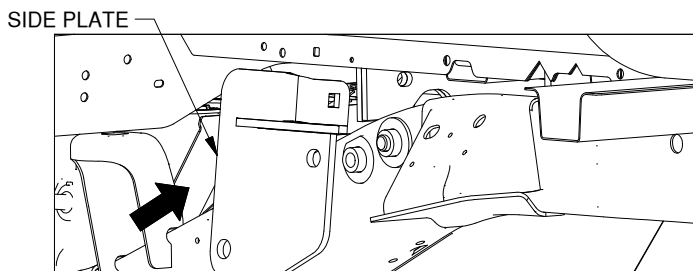

Figure H2: Looking in driver side wheel well.

3. **Place bolt guide assembly.** Feed the 5/8" bolt guide assembly into the large frame hole, as shown in Figure H3, so that the bolt sticks out of the frame and through the lower hole in the side plate. Secure this connection with a serrated flange nut.

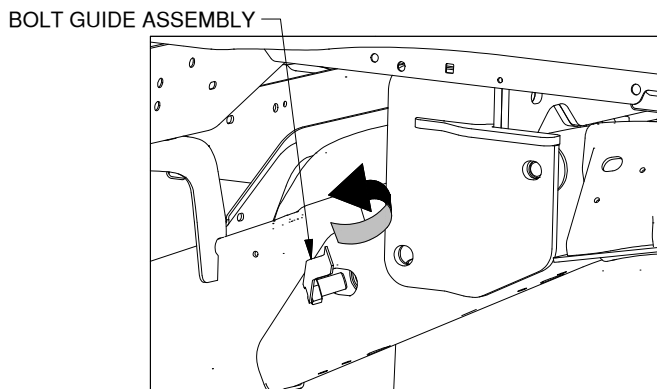

Figure H3: Looking at driver side frame.

4. **Secure side plate.** Push the longer 5/8" cap screw that is positioned in the frame, through the side plate. Secure it with a flat washer, lock washer, and nut, as shown in Figure H4.

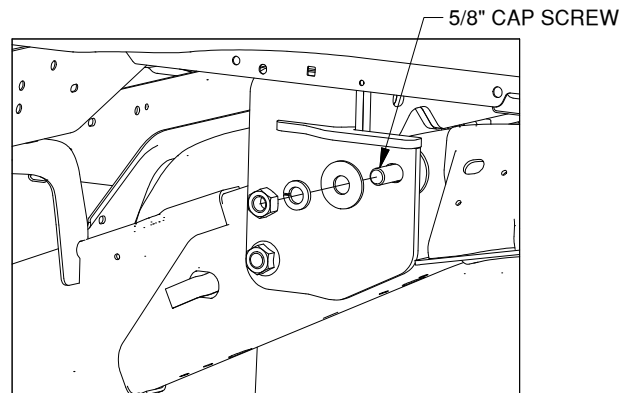

Figure H4: Looking at driver side frame.

5. **Pull fish wire through the cross members.** Feed the coil end of a fish wire through the holes in the front cross member parts, and the hole in the driver side plate. Move the end of the fish wire into an open space below the fuel tank and other obstacles, see Figure H5. Attach a 1/2" x 2" carriage bolt and pull the fish wire and bolt through all three parts.

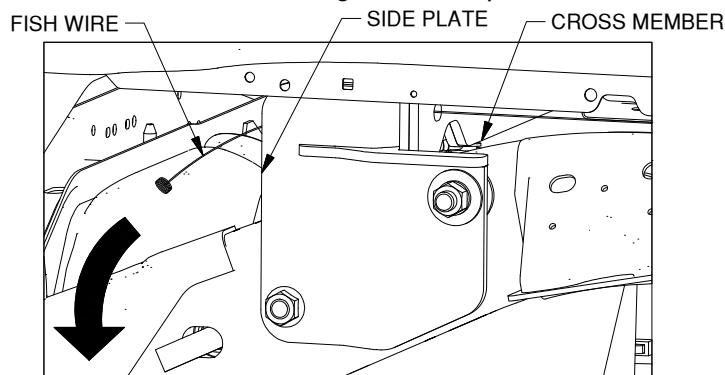

Figure H5: Looking at driver side frame.

6. **Secure cross members to side plate.** Make a small bend in the tail of one bolt retainer, see Figure H6. Slide the groove of the retainer over the threads as close to the cross member as possible, as shown in Figure H7. Rotate the tool clockwise to temporarily secure the tool to the carriage bolt while the fish wire is removed and the hardware is added.

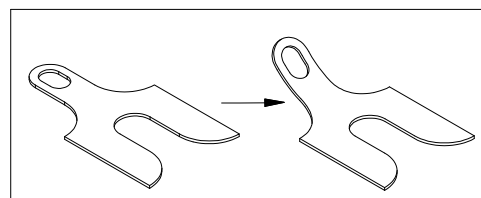

Figure H6: Bolt retainer before and after.

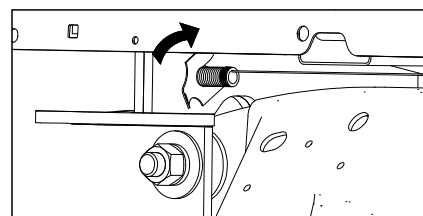

Figure H7: Close-up of carriage bolt installation.

**Continued on the next page.**

7. **Secure hardware.** Remove the fish wire and secure the carriage bolt with a flat washer, lock washer, and finish nut. Remove the bolt retainer by pulling on the bent tail.
8. **Repeat these steps to install the passenger side plate.**

## SECURE HITCH

1. **Tighten center section.** With the top surface of the center section firmly against the truck bed, tighten the eight 1/2" bolts securing the cross members to the center section.
2. **Square the hitch.** With a tape measure, check the distance between the Turnoverball hitch and the nearest bed cross member. The distance between the hitch and the cross member should be consistent on the driver side and the passenger side of the hitch, see Figure I1.

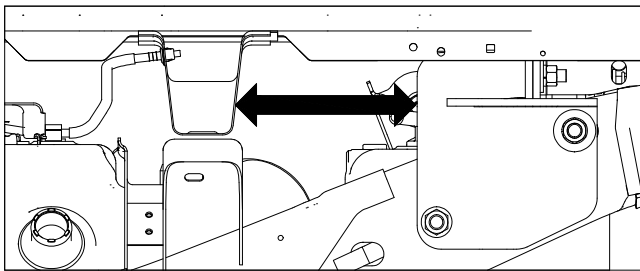

Figure I1.

**IMPORTANT:** The hitch must be square in the truck. If the center section is not parallel with the axle, certain accessories to the Turnoverball hitch will not be square with the truck.

3. **Continue tightening hitch.** Use the following sequence to tighten all remaining fasteners:
  - **First;** Tighten the bolts attaching the cross member brackets to the rear cross member.
  - **Second;** Tighten the carriage bolts attaching the front cross members to the side plates.
  - **Third;** Tighten the bolts attaching the cross member brackets to the inside of the frame.
  - **Fourth;** Tighten the 5/8" bolts attaching the side plates to the outside of the frame.
4. **Torque all fasteners.** Torque the 1/2" hardware connections to 110 ft. lbs. and 5/8" hardware connections to 150 ft. lbs.

**⚠ Failure to follow the bolt tightening sequence as listed above may result in the hitch components being misaligned which could affect the performance of the hitch, or result in property damage, or serious injury.**

5. **Disengage lifting device.** If a lifting device was used to hold the center section in place during the installation, remove it at this time.

6. **Replace the vent tube.** Replace the vent tube previously removed from the passenger side frame rail by placing it through the hole in the cross member bracket and into the frame.
7. **Replace the wiring connector.** Replace the wiring connector on the bracket welded to the round frame cross member if it was removed prior to installation.

## INSTALL LATCH PIN RELEASE HANDLE

**IMPORTANT:** The latch pin will not function properly if the handle is not installed correctly.

1. **Insert the handle.** Install the latch pin release handle by inserting it through the slot in the end of the center section on the driver side of the truck. Align the handle eyelet with the hole in the latch pin tab so the handle is in line with the latch.
2. **Secure the handle.** Attach the handle to the latch pin as shown in Figure J1. The head of the bolt must be on the handle side, and the lock nut must be on the tab side. The tab is welded to the pin in an offset position so that the handle will be lined up over the center of the pin. If the handle is fastened to the other side of the tab, the handle will not function properly. When installed correctly the latch pin may be disengaged from the ball by pulling on the handle from the driver side wheel well and rotating the handle clockwise.

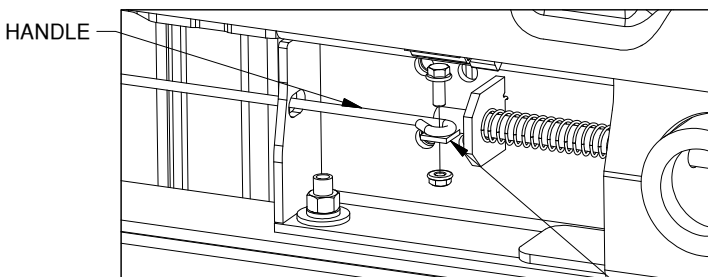

Figure J1: Looking up at center section

# INSTALL SAFETY CHAIN

## U-BOLTS

This Turnoverball hitch is equipped with holes in the center section for mounting safety chain U-bolts. The hitch is designed so that the U-bolts will be in a low rib of the truck bed in order to reduce the amount of obstruction in the bed. The center section of the hitch may have more than one set of holes. One set of holes should match up with a low rib of the truck bed. Carefully examine the safety chain holes in the center section to determine which holes are under a low rib, see Figure K1.

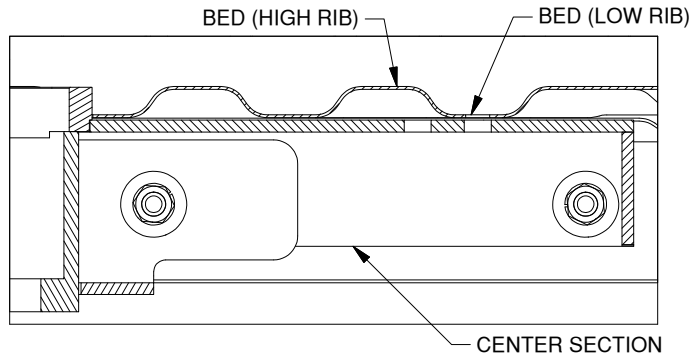
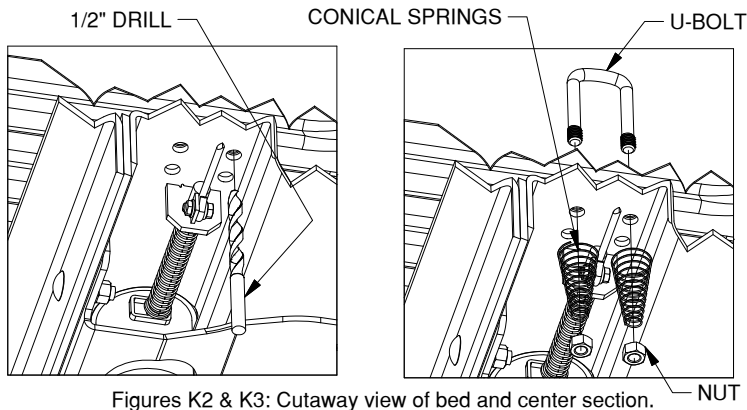

Figure K1: Cutaway view of bed and center section.

1. **Drill the holes.** From under the bed use a drill and a 1/2" drill bit to drill through the bed using the four holes that match up with a low rib in the truck as a guide. Remove any burrs created during the drilling process, see Figure K2.
2. **Install the U-bolts.** From the top side of the truck bed, drop a U-bolt in each set of holes.



Figures K2 & K3: Cutaway view of bed and center section.

3. **Add springs.** Place a conical spring over each leg of the U-bolts and secure with a 1/2" lock nut, see Figure K3. Tighten the lock nut until the nut is flush with the end of the U-bolt.

## PREPARE FOR TOWING

1. **Replace the inner fender guards.** Replace the inner fender guards if removed. If a fender liner restricts the movement of the handle, it is recommended that it be modified by cutting a relief slot or hole to allow the handle to move freely.

2. **Replace the spare tire** If the spare tire was removed prior to installing the hitch, replace it at this time.
3. **Retract the pin.** Pull the handle out all the way until it stops then rotate it clockwise. The handle should stay in this position. The latch should only be put in this open position when inverting the 2-5/16" ball or installing a B&W towing accessory.

- ⚠ **The handle operates in a very tight space within the wheel well of the truck. Use caution when operating the handle so that your hands and fingers do not get injured on the sharp edges of the truck, or by getting pinched against the frame due to the force of the spring loaded latch pin.**
  - ⚠ **Operating the tow vehicle while the latch is in the open position may allow the handle to come into contact with the rear tire. This may damage the tire or the handle and could lead to serious injury or death.**
4. **Lubricate 2-5/16" ball.** Apply a light coating of grease to the corners on the square shank of the 2-5/16" ball.
  5. **Engage pin.** Rotate the handle counterclockwise until the handle retracts and engages the 2-5/16" ball.
- ⚠ **When installed properly the latch pin will pass through the 2-5/16" ball and fully engage through both walls of the hitch receiver. Failure of the pin to engage the ball and hitch properly could result in a loss of attachment between the trailer and the tow vehicle.**

## OPERATION & MAINTENANCE

- Always be sure that latch pin is fully engaged in the socket before towing.
- Inspect hardware connections before towing to be sure that they are secure.
- Measure and determine turning clearance with cab before towing unfamiliar trailers. Additional products for increasing turning clearance are available from B&W.
- When inverting the ball, inspect the ball's relationship with the truck's differential and drive line to ensure proper clearance. **DO NOT INVERT THE BALL WHEN HAULING HEAVY LOADS ON 2 WHEEL DRIVE TRUCKS.** A plug for the socket is available from B&W so that the ball may be removed and the socket may be covered when hauling heavy loads.
- Periodically grease the corners on the square shank of the 2-5/16" ball.