

Installation Instructions

SHPE1500, SHPE1500RED, SHPE1500YEL Series SaltDogg® Electric Drive Poly Hopper Spreader 1.5 cubic yards

Serial Number 9700 and higher.

Protected by U.S. patent D520 524; 9,562,333

Table of Contents

General Information	1
Warranty Information	1
Safety Precautions	2
Installation Instructions	2-3
Spreader Operation	4
Spreader Maintenance	5
Repair Parts & Drawings	6-8

General Information

Spreader model numbers:

- SHPE1500 - spreader with standard chute
- SHPE1500X - spreader with extended chute

Overall Length: 92-1/8"

Overall Width: 50-1/2"

Overall Height (installed): 37-1/2"

Empty Weight: 410 lbs.

Capacity Struck: 1.5 cu. yd.

Average Installation Time: 3 hrs.

Vehicle Requirements

- 3/4 or 1 ton Pickup Truck above 8,500 lbs. GVWR.
- 135 amp or higher alternator is recommended.

Materials Recommended to Spread

CAUTION

Do not overload vehicle beyond the vehicle's GVWR or GAWR. Check vehicle's load rating certification sticker for maximum vehicle capacity.

Average Material Weights

Materials to use	Weight (pounds per cubic yard)
Fine Salt-Dry	2,250
Coarse Salt-Dry	1,431
Sand/Salt up to 50/50 Mix-Dry	2,700

Note: To calculate the total spreader weight (including ice control material), add the empty spreader weight plus the ice control material and spreader accessories.



SHPE1500 SALTDogg SPREADER WARRANTY INFORMATION

This warranty replaces all previous warranties and no employee of this company is authorized to extend additional warranties, or agreements, or implications not explicitly covered herein.

Buyers Products Company warrants all parts of the product to be free from defects in material and workmanship for a period of two (2) years. Parts must be properly installed and used under normal conditions. Normal wear is excluded.

Any part, which has been altered, including modifications, misuse, accident, or lack of maintenance will not be considered under this warranty.

The sole responsibility of Buyers Products Company under this warranty is limited to repairing or replacing any part(s), which are returned, prepaid, 30 days after such defect is discovered, and returned part(s) are found to be defective by Buyers Products Company.

Authorization from Buyers Products Company must be obtained before returning any part. The following information must accompany defective parts returned to Buyers Products Company: RMA #, spreader model, serial number, date installed, and distributor from whom purchased.

Buyers Products Company shall not be liable for damage arising out of failure of any unit to operate properly, or failure, or delay in work, or for any consequential damages. No charges for transportation or labor performed on any part will be allowed under this warranty.

Safety Precautions

⚠ WARNING

Observe the following Safety Precautions before, during and after operating this spreader. By following these precautions and common sense, possible injury to persons and potential damage to this machine may be avoided.

1. Read the entire Installation Instructions before operating this spreader.
2. Read all safety decals on the spreader before operating.
3. Check to make sure all safety guards are securely mounted into place before operating this spreader.
4. Verify that all personnel are clear of the spreader spray area before starting or operating this spreader.
5. Do not over-load your vehicle beyond payload limits. If there are any questions, contact the vehicle manufacturer.
6. Do not adjust, clean, lubricate or unclog material jams without first turning off the spreader.
7. Do not climb on or in the spreader during operation.
8. Do not ride on the spreader while the vehicle is in motion.
9. Make sure the spreader is securely fastened to the vehicle in accordance with this manual.
10. Do not operate a spreader that is in need of maintenance or repairs.
11. Always disconnect the battery before removing or replacing electrical components.

Installation Instructions

1. Mounting the Spreader onto the Vehicle:

- A. Remove the tailgate from the vehicle.
- B. Check truck's bed for any sharp debris or foreign objects. These can cut and seriously damage poly hopper.
- C. Lift spreader using tie downs. See Figure 1.

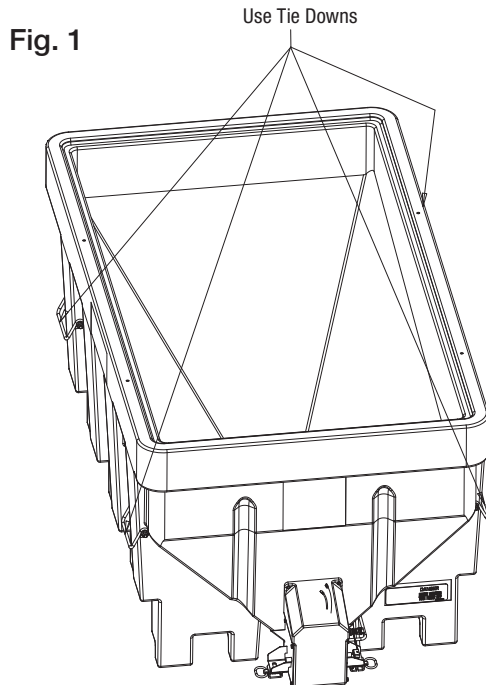

- D. Slide spreader forward until the steps on rear legs of the spreader make contact with truck's bed. Measure the distance from the front of the truck bed to front of the hopper's front legs. Fabricate spacer to fit between front of the spreader and front of the bed as shown in Figures 2 & 3.

Fig. 2

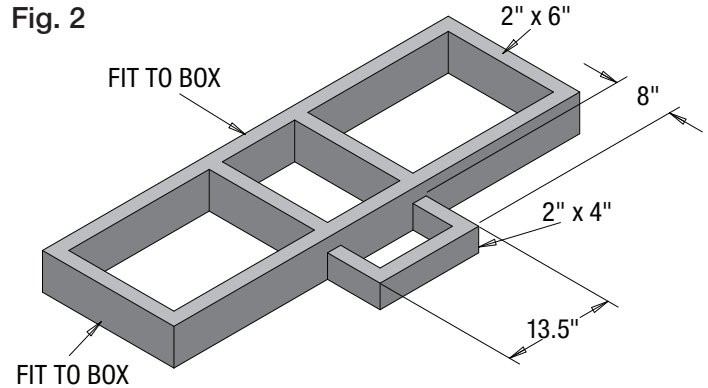
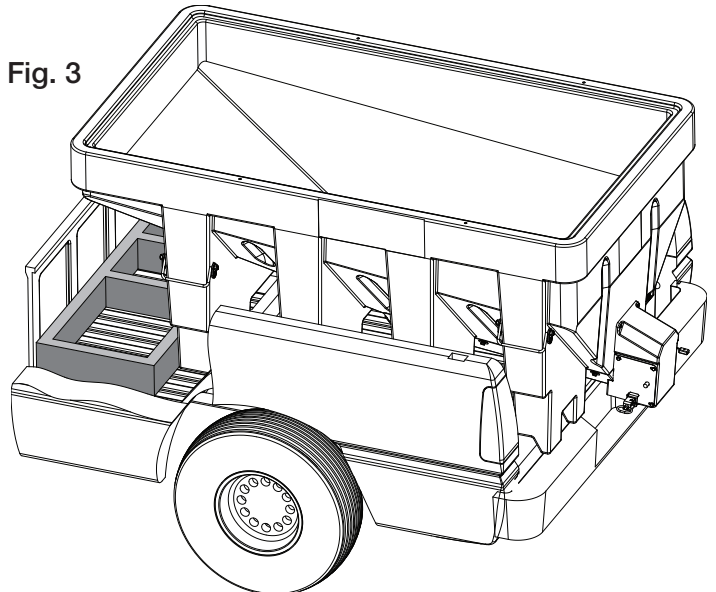
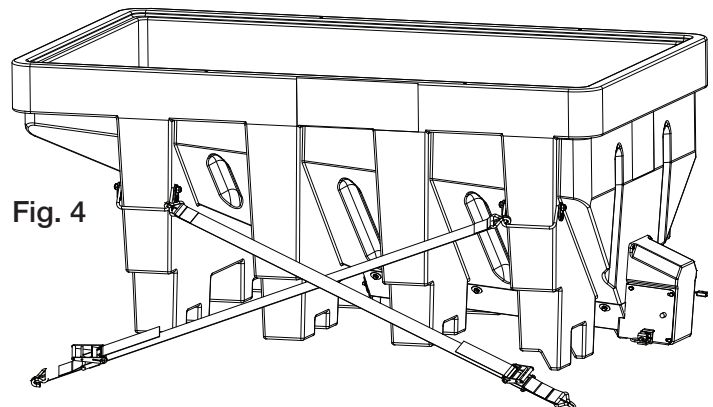

Fig. 3



- E. Center the spreader from side to side on the vehicle. Securely strap the spreader to the truck using four ratchet straps as shown in Figure 4.

Verify with the vehicle's manufacturer that the factory installed anchor points are designed for tie-down such load. Inspect straps and hardware after each time spreader is loaded. Tighten straps and hardware if necessary.



2. Mounting the Spinner/Chute Assembly

A. Attach the Chute Assembly to the spreader. First, hook the Chute to the spreader by openings in the Chute's handle (Fig. 5).

Fig. 5

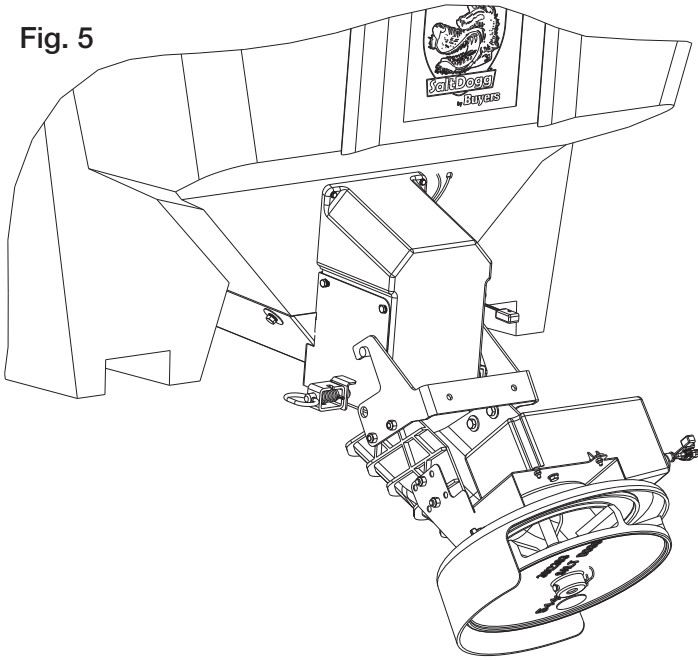

B. Rotate the chute into operating position and lock using the two spring latches (Fig. 6).

Fig. 6

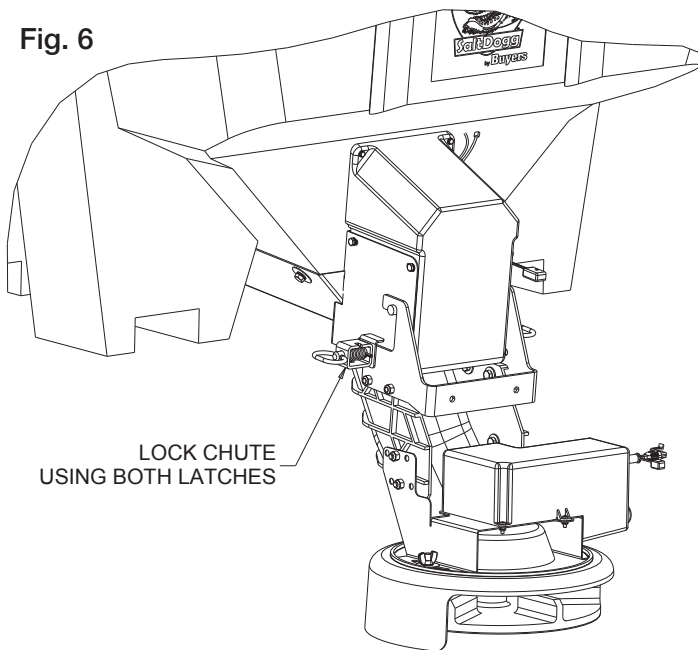

WARNING

Do not drill holes into fuel tanks, fuel lines, through electrical wiring, etc that may be damaged by drilling.

3. Install Control Box & Vehicle Wiring Harness (Fig.7).

NOTE: THIS IS A WIRE GROUND ELECTRICAL SYSTEM! NO CONNECTIONS TO TRUCK'S FRAME OR BODY ALLOWED! ALWAYS DISCONNECT BATTERY BEFORE ATTEMPTING TO INSTALL ELECTRICAL COMPONENTS ON YOUR VEHICLE.

WARNING

Use extreme caution when working around an operating vehicle engine.

To insure good performance of your spreader, check the condition of truck's electrical system. Using digital voltmeter, check alternator and battery voltage. The voltage reading should fall between 13.6 and 15.3 volts with engine running, head lights and heater fan turned on. If voltage reading falls out of this range, check and adjust your electric system.

A. Lay out a wiring path for the Vehicle Wiring Harness. Connect the Wire Harness smaller terminal to the Chute's harness, large terminal to the Hopper's harness. Drill all necessary holes or use existing ones to pass the round connector into the trucks cab. Secure harness to truck's frame.

B. Mount the Controller in a convenient location in the truck cab. Do not mount controller directly in front of the heat vents. Allow ample air space around controller. Protect controller from water, dirt and dust.

WARNING

DO NOT MOUNT CONTROLLER IN WAY OF AIR BAG DEPLOYMENT

C. Apply dielectric grease or similar compound to connectors before assembly. Connect the round connector on the wire harness to the round connector on the controller.

D. Lay out path for the power cable in the truck's engine compartment. Drill hole in the firewall or use an existing one to pass the wire harness. Passing the power cable from inside of the cab to the battery is recommended to protect the large high amperage connector. Do not route the power cable close to exhaust system!

E. Connect power cable connector to controller.

F. Connect the power cable ring terminals to the truck battery (fig. 7).

ATTENTION

Do not connect black (negative) wire to any part of vehicles frame. Connect this terminal to battery's negative terminal.

Fig. 7

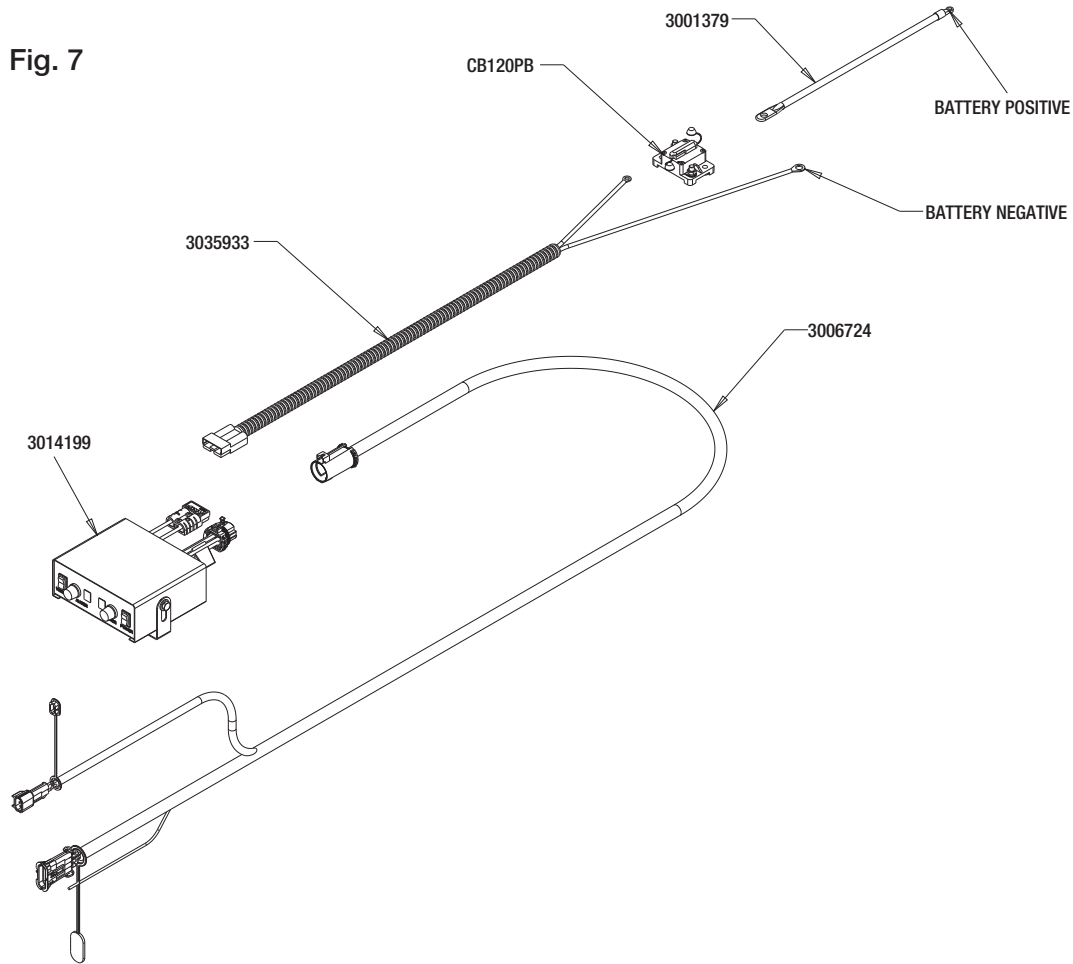

Thoroughly clean battery terminals. Make sure battery terminals have no tarnish or corrosion.

DO NOT CONNECT WIRE HARNESS TO DAMAGED OR CORRODED TERMINALS! IT MAY RESULT IN OVERHEATING, LOST POWER AND POTENTIAL CONTROLLER DAMAGE!

G. Attach utility light (optional) to spreader hopper in desired location. Connect as shown in Fig. 7. Use utility light kit part number 3018009.

H. See controller instructions for latest updates and error codes.

Spreader Operation

- 1.** Different materials absorb moisture at different rates and some materials may not perform as desired. Substitution of an alternative material may be necessary for optimum performance.
- 2.** When filling hopper use the supplied screen to prevent large chunks of material and debris in the material to get into hopper and cause damage.
- 3. Material must never be left in hopper for an extended period of time. Material will absorb moisture, bind, harden and could prevent spreader from proper operation or may damage the spreader.**
- 4.** The SHPE1500 spreader is equipped with a dual independent speed controller with warning indicators and a vibrator switch.

To start the spreader, press the ON-OFF switch. Switch will illuminate. The auger will accelerate to full speed for 2 seconds, then slow down to dialed speed. The spinner will accelerate to full speed for 2 seconds, then slow down to dialed speed.

5. To activate the vibrator press the vibrator switch ON. Vibrator switch will illuminate.

6. To stop the spreader, push ON-OFF switch to OFF position.

Material Flow Adjustments

Always use screen during spreader operation!

Various materials have different moisture absorption rate, some materials may not perform as desired. Therefore, the substitution of the alternate material may be necessary for optimum performance.

SHPE1500 has two discharge openings in the bottom of the hopper. Material flow through these openings can be controlled using two sliding baffles. The spreader is shipped from the factory with baffles adjusted for dry salt. In this setting rear baffle has 4.0" opening and baffle in the middle of the hopper has 2.0" opening. However if you are using a sand/salt mixture or any chunky and hard to flow materials, adjust the rear baffle opening to 3" and the baffle in the middle of the hopper to a 1" opening.

IMPORTANT! -Always open rear (closer to gear motor compartment) opening first. Always turn off power before adjusting baffles!

Spread Pattern Adjustment

Spread pattern can be adjusted by changing spinner disc speed on controller by turning Spinner knob to desired speed level from 1 (low) to 9 (high). Direction of material spread can also be adjusted by rotating shield on chute assembly. To rotate shield lose 2 wing nuts, rotate shield in desired direction, and retighten wing nuts. See Fig. 8. Make sure that after adjustment, bracket stays inside shield groove located on top of shield. In addition, chute assembly can be adjusted to lighter (drier) and heavier (more moist) materials. Use different holes on bracket for lighter or heavier materials to have material drop on spinner disc center. See Fig. 8.

Fig. 8

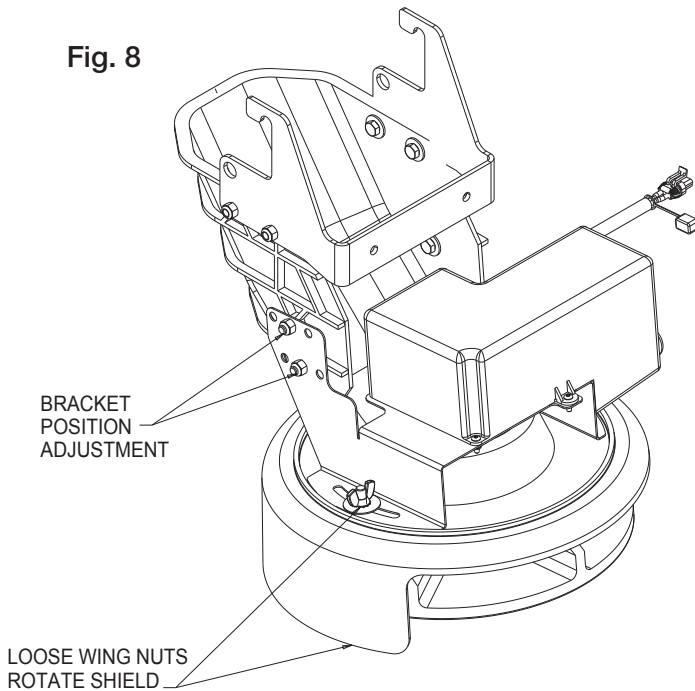

Controller Warnings

Check controller instruction sheet for latest controller updates and troubleshooting codes. Controller instruction sheet is inside controller shipping box.

IMPORTANT! INSTALLER, DO NOT DISCARD CONTROLLER INSTRUCTION SHEET. STAPLE SHEET TO SPREADER MANUAL AND GIVE TO END USER!

Note: To unclog auger manually, first remove the chute. Apply 1-1/4" open wrench on auger's nut. Turn auger counterclockwise several times.

Note: Do not run the vibrator longer than 30 minutes with 15 minutes between runs to avoid overheating.

Spreader Maintenance

1. Wash spreader after every use. Make sure no material is left under auger and/or inside trough.
2. Inspect and retighten fasteners after every 5-7 hours of operation.
3. Lubricate bearing every 7-10 hours of operation using general automotive grease.

4. Inspect terminals/connectors every time you disconnect spreader from wire harness. Apply thin layer of dielectric grease on terminals. If any tarnish/corrosion is found, clean terminals and apply dielectric grease.
5. Use dielectric grease on all electrical connectors before an electrical connection is made or after connector is disconnected.
6. Grease and spray with lubricant Auger bearing after every 20 hours of use.
7. Empty the spreader of all ice control materials when not in use. Wash out the spreader to prevent material builds up.
8. It is recommended to cover spreader with the tarp during storage periods. Tarp can be attached to anchors on both sides of tie downs.

WARNING

Never remove spreader with material in hopper.

End of Season Maintenance

1. Wash spreader. Make sure no material or residue is left in and outside the hopper.
2. Lubricate bearing using general automotive grease.
3. Inspect wire harness, connectors for broken insulation, missing components. Replace if necessary.
4. Apply dielectric grease on all electrical connectors.
5. Store hopper indoors, in a dry, cool place.
6. Remove controller from truck. Store controller indoors, in a dry, cool place.
7. Inspect wire near connectors. Check for broken or missing insulation. Check for tarnished or corroded wires. Trim corroded wires and replace connectors if necessary.

Summer Storage

1. Apply dielectric grease or similar protective compound on all electrical connectors & protect them with caps before storage.
2. Disconnect and remove speed controller from vehicle and store it in dry and cool place. Protect controller from excessive heat and moisture.
3. Clean hopper and trough from all kinds of debris.
4. Remove, thoroughly lubricate and reinstall trough bearing.
5. Protect hopper from excessive temperatures during summer storage.

Repair Parts - Standard Chute Assembly

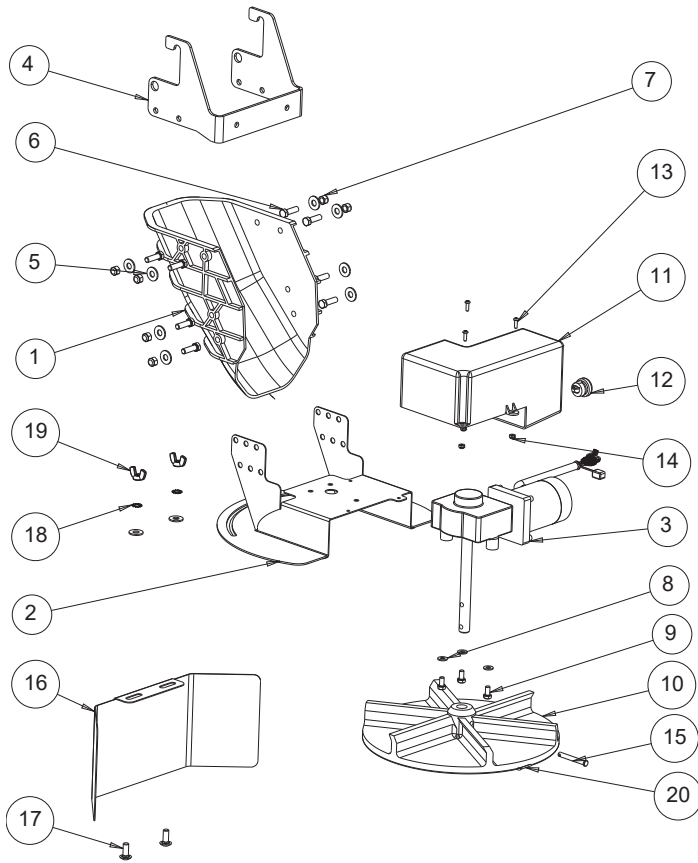

Bill of Materials

ITEM	PART NO.	QTY.	DESCRIPTION
1	3025063	1	CHUTE POLY, SHPE STD. LENGTH
2	3033665	1	BRACKET WELDMENT, CHUTE
3	3006833	1	GEAR MOTOR 12 VDC. SPINNER
4	3027699	1	HANDLE, CHUTE
5	FWF038100007SS	10	WASHER, FLAT 3/8 USS SST
6	FCS038016125SS	8	SCREW, HHC-3/8-16 X 1.25 SST
7	FNE038016044SS	8	NUT, NYLOCK 3/8-16 X 7/16 SST
8	FWF031075006SS	3	WASHER, 5/16 SAE SST
9	FCS031018063SS	3	SCREW, HHC 5/16-18 X 5/8 SST
10	3012393	1	SPINNER, 14" POLY CW
11	3025067	1	ENCLOSURE, GEAR MOTOR
12	3025065	1	BUSHING STRAIN RELIEF
13	3001537	3	SCREW, SOCBHCS #10 X 5/8 SST
14	FNE010024024SS	3	NUT, ELASTIC STOP 10-24 SS
15	3007113	1	PIN, CLEVIS, 5/16 X 2-1/2, .141 HOLE ZN
16	3017444	1	SHIELD, CHUTE
17	3014960	2	BOLT, 3/8-16 X 1 CARRIAGE SHORT NECK SS
18	3017356	2	WASHER, EXTERNAL TOOTH LOCK 3/8 SS
19	3025064	2	NUT, 3/8-16 WING, SST
20	3014994	1	PIN, COTTER, 1/8IN X 1IN SST

Repair Parts - Extended Chute Assembly

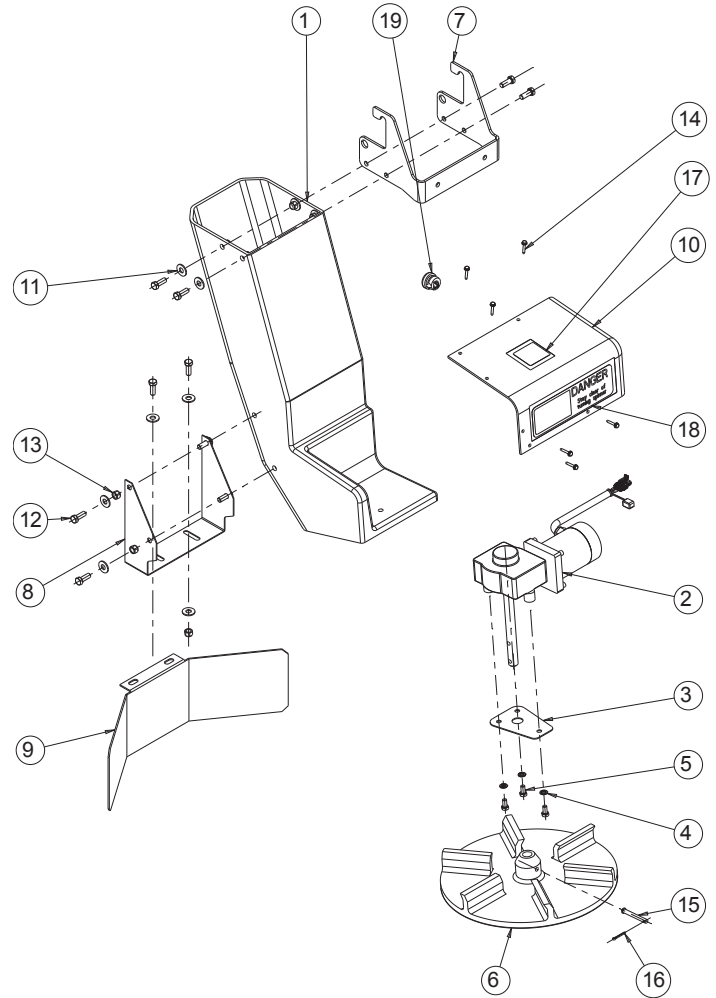

Bill of Materials

ITEM	PART NO.	QTY.	DESCRIPTION
1	3007526	1	CHUTE POLY. EXT. LENGTH
2	3006833	1	GEAR MOTOR 12 VDC. SPINNER
3	3007824	1	RETAINER GEARMOTOR, CHUTE
4	FWL031058008SS	3	WASHER, 5/16 LOCK SST
5	FCS031018063SS	3	SCREW, HHC 5/16-18 X 5/8 SST
6	3012393	1	SPINNER, 14" POLY CW
7	3027699	1	HANDLE, CHUTE
8	3007564	1	BRACKET, SHIELD SST
9	3007004	1	SHIELD, SPINNER, SHPE1500
10	3007413	1	COVER, GEAR MOTOR, CHUTE
11	FWF038100007SS	16	WASHER, FLAT 3/8 USS SST
12	FCS038016100SS	10	SCREW, HHC 3/8-16 X 1 304 SST
13	FNE038016044SS	10	NUT, NYLOCK 3/8-16 X 7/16 SST
14	3007522	6	SCREW, SHEET MTL #12x1.0 HEX WASHER HD SST
15	3007113	1	PIN, CLEVIS, 5/16 X 2-1/2, .141 HOLE ZN
16	FPC013000100	1	COTTER PIN, 1/8 X 1, ZINC
17	3002631	1	LABEL, "NO STEP"
18	3007844	1	DECAL, DANGER STAY CLEAR
19	3025065	1	BUSHING STRAIN RELIEF

Repair Parts-Hopper Assembly

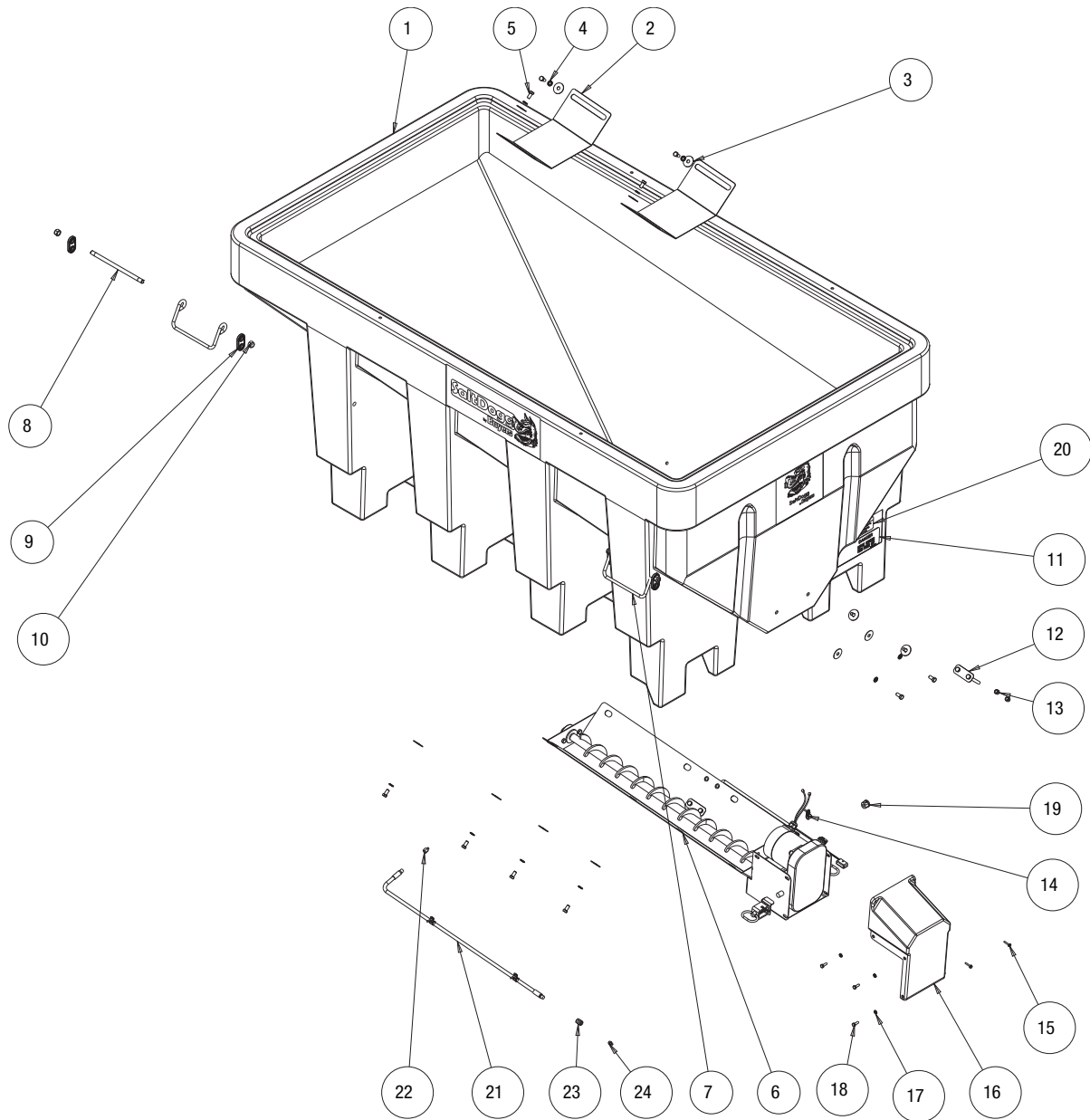

Bill of Materials

ITEM	PART NO.	QTY.	DESCRIPTION
1	3005574	1	HOPPER POLY 1.5 CU. YA., BLACK
	3025162	1	HOPPER POLY 1.5 CU. YA., RED
	3025164	1	HOPPER POLY 1.5 CU. YA., YELLOW
2	3006959	2	BAFFLE, SHPE1500
3	3007115	14	WASHER, FLAT 3/8 X 1.5 X.048 SST
4	FWL038069009SS	14	WASHER, LOCK RHS-3/8 SST
5	FCS038016075SS	14	SCREW, HHC-3/8-16 X 3/4 SST
6	3011865	1	TROUGH ASSEMBLY, SHPE
7	3006958	4	TIE DOWN
8	3006974	4	STUD, 1/2-13x.75 BOTH ENDS, 9.75" LG, ZC
9	3009802	8	ANCHOR, TARP, POLY SHPE
10	FNE050013053	8	NUT, NYLOCK 1/2-13 ZINC

ITEM	PART NO.	QTY.	DESCRIPTION
11	9240132	1	DECAL #2, DANGER BEFORE SVCE
12	3007731	1	BRACKET VIBRATOR, LONG SST
13	FNE038016044SS	2	NUT, NYLOCK 3/8-16 X 7/16 SST
14	4375	4	CLAMP, HOSE .4375, 9/32 HOLE
15	3007522	6	SCREW, SHEET MTL #12x1.0 HEX WASHER HD SST
16	3007236	1	COVER GEARMOTOR
17	FWL025050006SS	6	WASHER, 1/4 IN. SPRING LOCK SST
18	FCS025020075SS	6	SCREW, CAP 1/4-20 X 3/4 SST
19	3007821	1	STRAIN RELIEF BUSHING
20	3012898	1	DECAL, CHECK STRAPS
21	3022955_	1	HOSEGREASE, 1/8 NPT, 36 IN LONG
22	3020713	1	CONNECTOR, MALE, FEMALE
23	H3309X2	1	CONNECTOR, FEM NPT TO FEM NPT 1/8 X 1/8
24	800	1	GREASE FITTING, 1/4 STD

Repair Parts-Trough Assembly

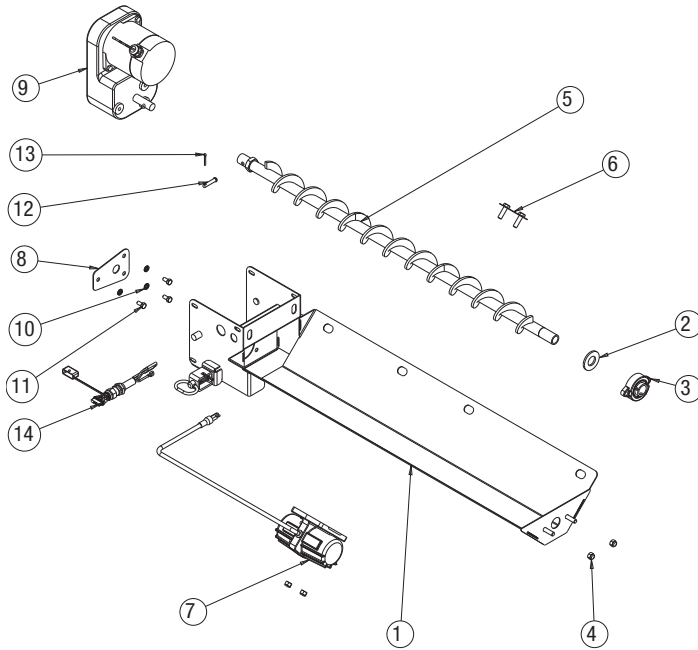

Bill of Materials

ITEM	PART NO.	QTY.	DESCRIPTION
1	3007357	1	TROUGH WELDMENT SHPE1500
2	3007000	1	GASKET, FELT BEARING
3	3018919	1	BEARING, 2-HOLE FLANGED 1" SST
4	FNE038016044SS	4	NUT, NYLOCK 3/8-16 X 7/16 SST
5	3018007	1	AUGER SHPE SST
6	3007730	1	BRACKET, VIBRATOR SHORT
7	3007416	1	VIBRATOR 200 LBS 12 VDC
8	3007824	1	RETAINER GEARMOTOR, CHUTE
9	3009995	1	GEAR MOTOR, AUGER SHPE
10	FWL031058008SS	3	WASHER, 5/16 LOCK SST
11	FCS031018063SS	3	SCREW, HHC 5/16-18 X 5/8 SST
12	FPY031000150	1	PIN, CLEVIS, 5/16 X 1-1/2, W/ 5/32 PH, ZN
13	3014994	1	PIN, COTTER, 1/8IN X 1IN SST
14	3006844	1	WIRE HARNESS

Service Parts and Accessories

PART NO.	DESCRIPTION
3012431	Replacement Motor for 3006833, 3027293
3021617	Replacement Coupler for 3006833, 3027293
3019085	Replacement Motor for 3009995
3021616	Rocker Switch for Controller 3014199
3020624	Remote Grease Kit
LS6	Wetting System, 30 Gal.
LS6H	Wetting System, Hydraulic, 30 Gal.

Repair Parts-Spreader

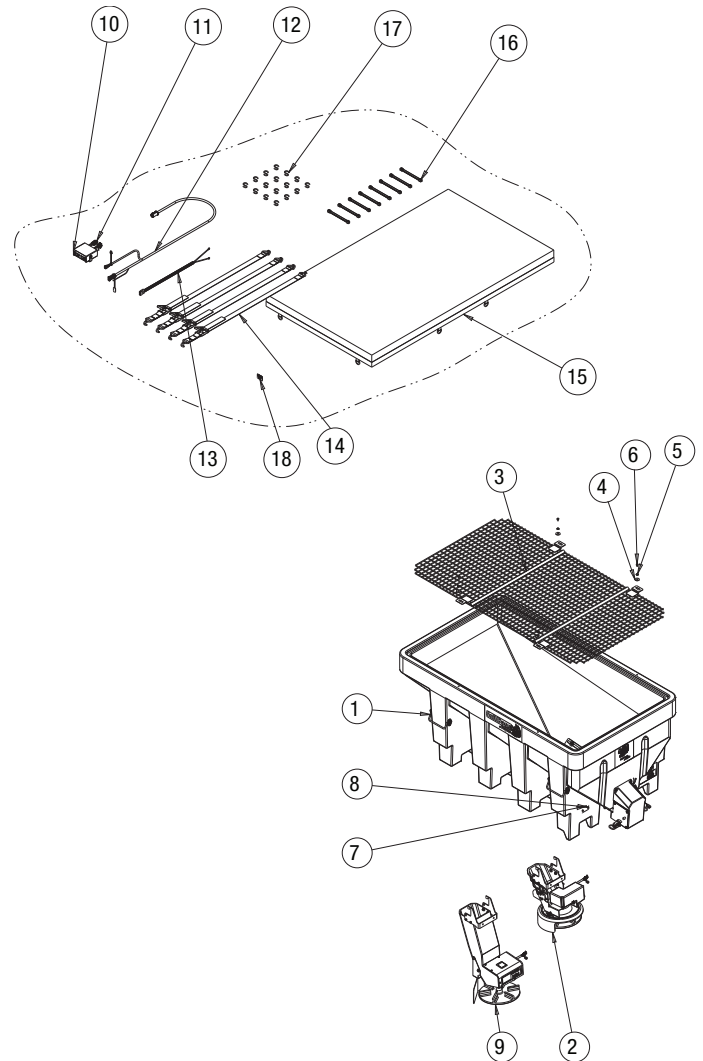

Bill of Materials

ITEM	PART NO.	QTY.	DESCRIPTION
1	3006837	1	HOPPER POLY 1.5 CU YD ASSEMBLY
	3025163	1	HOPPER POLY 1.5 CU YD ASSEMBLY, RED
	3025165	1	HOPPER POLY 1.5 CU YD ASSEMBLY, YELLOW
2	3025070	1	CHUTE ASSEMBLY. STD LENGTH
3	3007039	1	SCREEN, WELDMENT SHPE1500
4	3007115	4	WASHER, FLAT 3/8 X 1.5 X.048 SST
5	FWL038069009SS	4	WASHER, LOCK RHS-3/8 SST
6	3006760	4	SCREW, HHC-3/8-16 X 1/2 SST
7	3008987	1	PLATE, SERIAL NO. SHPE1500 SERIES
8	3007522	2	SCREW, SHEET MTL #12x1.0 HEX WASHER HI
9	3007527	1	CHUTE POLY EXT. ASSEMBLY
10	3028126	1	HARDWARE KIT SHPE1500
11	3014199	1	CONTROLLER, SHPE, SALT DOGG
12	3006724	1	WIRE HARNESS, MAIN
13	3035933	1	POWER CABLE, CONTROL BOX
14	1496505	1	HOLD DOWN KIT, SPREADER (4 STRAPS)
15	3006964	1	TARP, SHPE1500
16	TS9	8	STRAP, RUBBER TARP 9"
17	9225	16	S-HOOK, 2.5" ZN, TARP STRAP
	3001379	1	BATTERY CABLE
	CB120PB	1	CIRCUIT BREAKER