

Installation Instructions

SHPE1000 Series SaltDogg® Electric Drive Poly Hopper Spreader 1.0 cubic yard

U.S. PATENT 9,562,333

Table of Contents

General Information	1
Safety Precautions	1
Warranty Information	2
Installation Instructions	2-4
Spreader Operation	5
Spreader Maintenance.....	5
Repair Parts & Drawings	6-10

General Information

Spreader models:

- SHPE1000- spreader with standard length chute
- SHPE1000X- spreader with extended length chute

Overall Length: 72 inches

Overall Width: 48 inches

Overall Height: (installed): 34 inches

Empty Weight: 343 lbs. (standard chute), 347 lbs. (extended chute)

Capacity Struck: 1.0 cu. yd.

Average Installation Time: 3 hrs.

Vehicle Requirements

- 1/2 or 3/4 ton pick-up truck.
- 135 AMP or higher alternator is recommended.

CAUTION

Do not overload vehicle beyond the vehicle's GVWR or GAWR.
Check vehicle's load rating certification sticker for maximum vehicle capacity.

Materials Recommended to Spread

Average Material Weights

Materials to use	Weight (pounds per cubic yard)
Fine Salt-Dry	2,250
Coarse Salt-Dry	1,431
Sand/Salt up to 50/50 Mix-Dry	2,700

Note: To calculate the total spreader weight (including ice control material), add the empty spreader weight plus the ice control material and spreader accessories.



Safety Precautions

⚠ WARNING

Observe the following Safety Precautions before, during and after operating this spreader. By following these precautions and common sense, possible injury to persons and potential damage to this machine may be avoided.

1. Read this entire Owners Manual before operating this spreader.
2. Read all safety decals on the spreader before operating.
3. Check to make sure all safety guards are securely mounted into place before operating this spreader.
4. Verify that all personnel are clear of the spreader spray area before starting or operating this spreader.
5. Do not over-load your vehicle beyond payload limits. If there are any questions, contact the vehicle manufacturer.
6. Do not adjust, clean, lubricate or unclog material jams without first turning off the spreader.
7. Do not climb on or in the spreader during operation. Do not ride on the spreader while the vehicle is in motion.
8. Make sure the spreader is securely fastened to the vehicle in accordance with this manual.
9. Do not operate a spreader that is in need of maintenance or repairs.
10. Always disconnect the battery before removing or replacing electrical components.

Installation Instructions

1. Mounting the Spreader onto the Vehicle:

- A. Remove the tailgate from the vehicle.
- B. Check truck's bed for all kinds of sharp debris or foreign objects. They can cut and seriously damage poly hopper.
- C. Lift spreader using tie downs (fig. 1), or using fork lift.
- D. Lower spreader into the truck bed.
- E. Center the spreader from side to side on the vehicle.

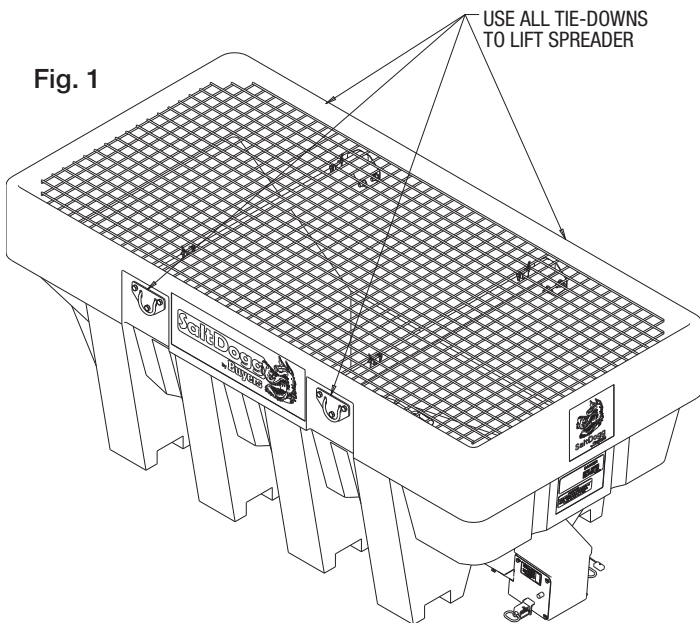
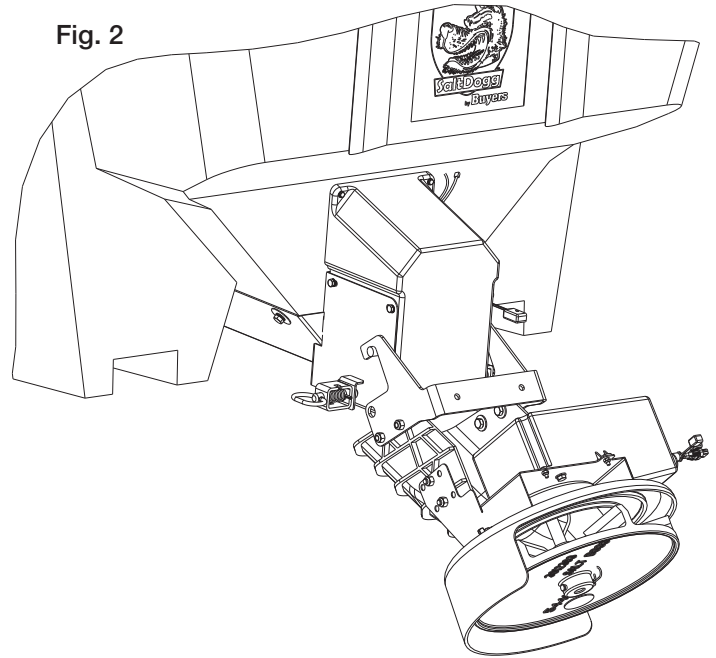

Fig. 1

- F. Attach the Chute Assembly to the spreader. First, hook the Chute to the spreader by openings in the Chute's handle.

Fig. 2



Then rotate the Chute into operating position and lock using two spring latches.

Fig. 3

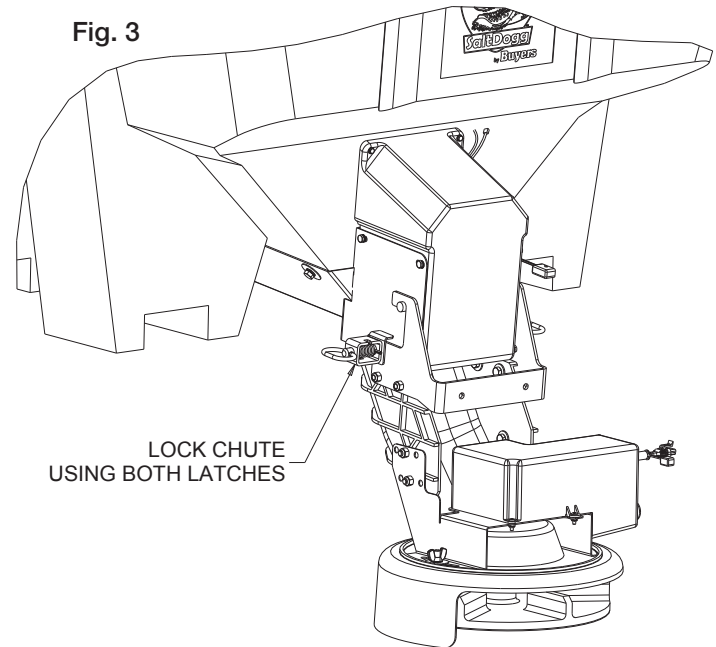

- G. Slide spreader towards front of the truck leaving adequate space between chute and truck (2-3 inches). Measure the distance from the front of the truck bed to front of the hopper's front legs. Fabricate spacer to fit between front of the spreader and front of the bed per Fig. 4 and Fig. 5

Fig. 4

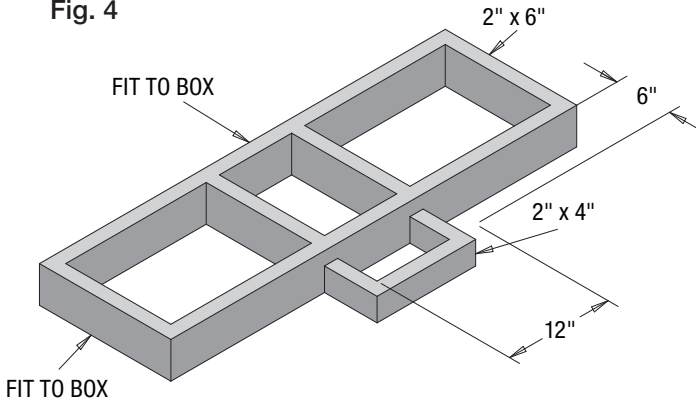
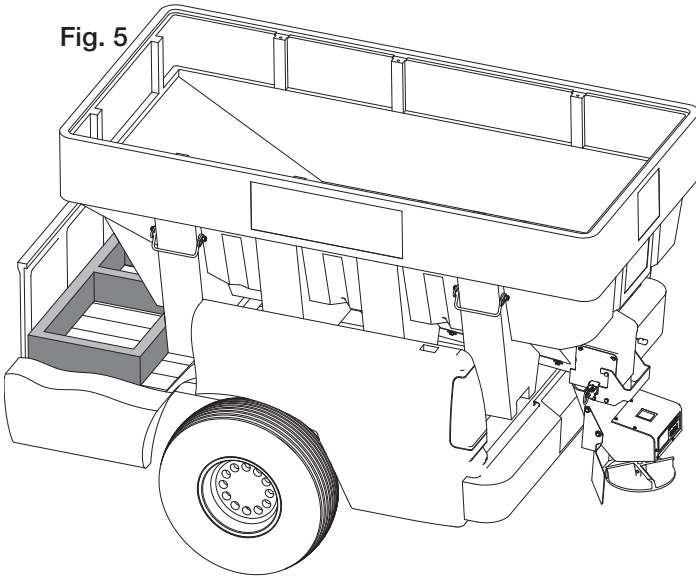
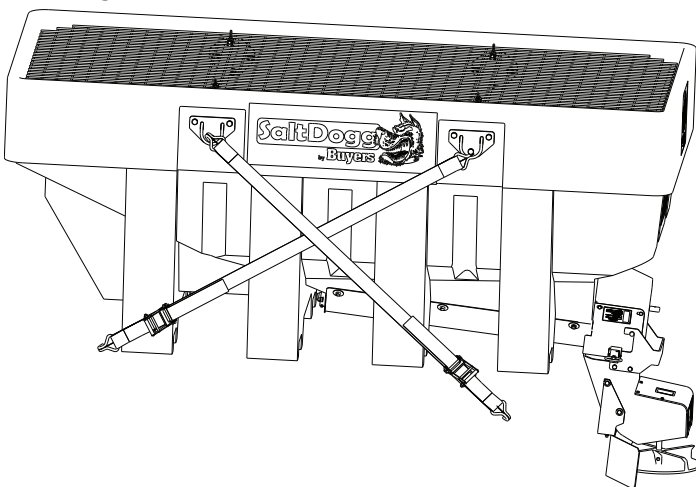

Fig. 5



H. Secure spreader using four ratchet straps as shown in Fig. 6. Tighten straps evenly to secure spreader in the middle of the truck box.

Fig. 6



Verify with the vehicle's manufacturer that the factory installed anchor points are designed for tie-down such load. Inspect straps and hardware after each time spreader is loaded. Tighten straps and hardware if necessary.

WARNING

Do not drill holes into fuel tanks, fuel lines, through electrical wiring, etc that may be damaged by drilling.

2. Install Control Box & Vehicle Wiring Harness (Fig. 7).
NOTE: THIS IS A WIRE GROUND ELECTRICAL SYSTEM! NO CONNECTIONS TO TRUCK'S FRAME OR BODY ALLOWED! ALWAYS DISCONNECT BATTERY BEFORE ATTEMPTING TO INSTALL ELECTRICAL COMPONENTS ON YOUR VEHICLE.

WARNING

Use extreme caution when working around an operating vehicle engine.

To insure good performance of your spreader, check the condition of truck's electrical system. Using digital voltmeter, check alternator and battery voltage. The voltage reading should fall between 13.6 and 15.3 volts with engine running, head lights and heater fan turned on. If voltage reading falls out of this range, check and adjust your electric system.

A. Lay out a wiring path for the Vehicle Wiring Harness. Connect the Wire Harness smaller terminal to the Chute's harness, large terminal to the Hopper's harness. Drill all necessary holes or use existing ones to pass the round connector into the trucks cab. Secure harness to truck's frame.

B. Mount the Controller in a convenient location in the truck cab. Do not mount controller directly in front of the heat vents. Allow ample air space around controller. Protect controller from water, dirt and dust.

CAUTION

Do Not Mount Controller In Way Of Air Bag Deployment. Do Not Drill Or Tap Into Controller! Warranty Will Be Void!

C. Apply dielectric grease or similar compound to connectors before assembly. Connect the round connector on the wire harness to the round connector on the controller.

D. Lay out path for the power cable in the truck's engine compartment. Drill hole in the firewall or use an existing one to pass the wire harness. Passing the power cable from inside of the cab to the battery is recommended to protect the large high amperage connector. Do not route the power cable close to exhaust system!

E. Connect power cable connector to controller.

F. Connect the power cable ring terminals to the truck battery (Fig. 7).

ATTENTION

Do not connect black (negative) wire to any part of vehicles frame. Connect this terminal to battery's negative terminal.

Fig. 7

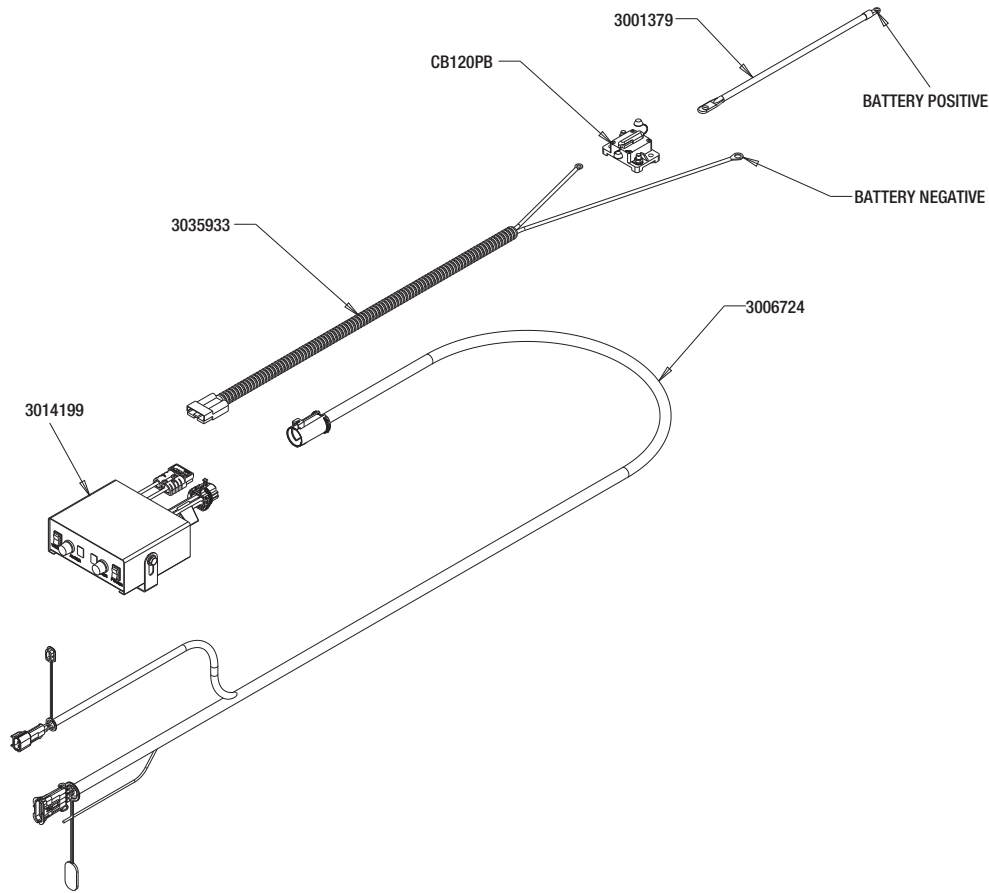

Thoroughly clean battery terminals. Make sure battery terminals have no tarnish or corrosion. DO NOT CONNECT WIRE HARNESS TO DAMAGED OR CORRODED TERMINALS! IT MAY RESULT IN OVERHEATING, LOST POWER AND POTENTIAL CONTROLLER DAMAGE!

G. Attach utility light (optional) to spreader hopper in desired location. Connect as shown in Fig. 7. Use utility light kit part number 3018009.

H. See controller instructions for latest updates and error codes.

Spreader Operation

- 1.** Different materials absorb moisture at different rates and some materials may not perform as desired. Substitution of an alternative material may be necessary for optimum performance.
- 2.** When filling hopper use the supplied screen to prevent large chunks of material and debris in the material to get into hopper and cause damage.
- 3. Material must never be left in hopper for an extended period of time. Material will absorb moisture, bind, harden and could prevent spreader from proper operation or may damage the spreader.**
- 4.** The SHPE1000 spreader is equipped with a dual independent speed controller with warning indicators and a vibrator switch. To start the spreader, press the ON-OFF switch. Switch will illuminate. The auger will accelerate to full speed for 2 seconds, then slow down to dialed speed. The spinner will accelerate to

full speed for 2 seconds, then slow down to dialed speed.

- 5.** To activate the vibrator press the vibrator switch ON. Vibrator switch will illuminate.
- 6.** To stop the spreader, push ON-OFF switch to OFF position.

Controller Warnings

Check controller instruction sheet for latest controller updates and troubleshooting codes. Controller instruction sheet is inside controller shipping box.

IMPORTANT! INSTALLER, DO NOT DISCARD CONTROLLER INSTRUCTION SHEET. STAPLE SHEET TO SPREADER MANUAL AND GIVE TO END USER!

Note: To unclog auger manually, first remove the chute. Apply 1/4" open wrench on auger's nut. Turn auger counterclockwise several times.

Note: Do not run the vibrator longer than 30 minutes with 15 minutes between runs to avoid overheating.

Material Flow Adjustments

Always use screen during spreader operation! Various materials have different moisture absorption rate, some materials may not perform as desired. Therefore, the substitution of the alternate material may be necessary for optimum performance.

SHPE1000 has one discharge opening covered with two adjustable deflectors. To adjust amount of material going through this opening loose two screws, slide deflectors to increase or reduce opening exposure. It is recommended

to expose more of rear (closer to truck's rear end) portion of discharge opening to increase flow without overloading auger gear motor. (Fig 8)

IMPORTANT! -Always turn off power before making any spreader adjustments!

Fig. 8

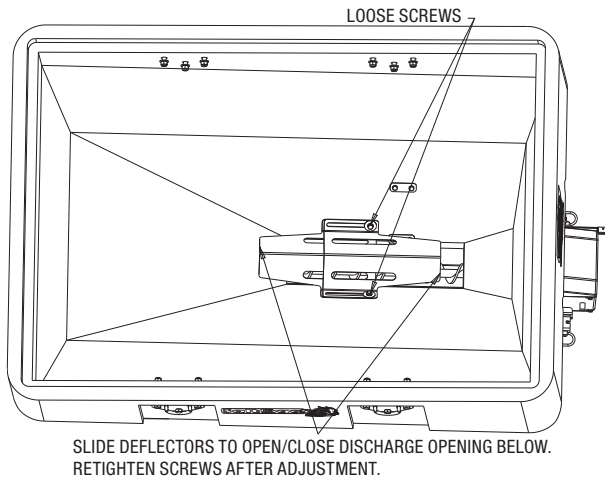

Spread Pattern Adjustment

Spread pattern can be adjusted by changing spinner disc speed on controller by turning Spinner knob to desired speed level from 1 (low) to 9 (high). Direction of material spread can also be adjusted by rotating shield on chute assembly. To rotate shield lose 2 wing nuts, rotate shield in desired direction, and retighten wing nuts. See Fig.9. Make sure that after adjustment, bracket stays inside shield groove located on top of shield. In addition, chute assembly can be adjusted to lighter (drier) and heavier (more moist) materials. Use different holes on bracket for lighter or heavier materials to have material drop on spinner disc center. See Fig.9.

Fig. 9

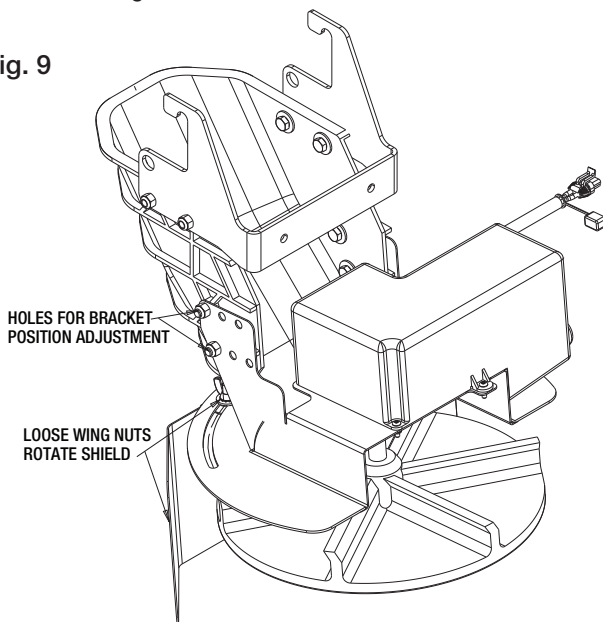

Spreader Maintenance

1. Wash spreader after every use. Make sure no material is left under auger and/or inside trough.
2. Inspect and retighten fasteners after every 5-7 hours of operation.

3. Lubricate bearing every 7-10 hours of operation using general automotive grease.
4. Inspect terminals/connectors every time you disconnect spreader from wire harness. Apply thin layer of dielectric grease on terminals. If any tarnish/corrosion is found, clean terminals and apply dielectric grease.
5. Use dielectric grease on all electrical connectors before an electrical connection is made or after connector is disconnected
6. Empty the spreader of all ice control materials when not in use. Wash out the spreader to prevent material builds up.
7. It is recommended to cover spreader with the tarp during storage periods.



WARNING

Never remove spreader with material in hopper.

End of Season Maintenance

1. Wash spreader. Make sure no material or residue is left in and outside the hopper.
2. Lubricate bearing using general automotive grease.
3. Inspect wire harness, connectors for broken insulation, missing components. Replace if necessary.
4. Apply dielectric grease on all electrical connectors.
5. Store hopper indoors, in a dry, cool place.
6. Remove controller from truck. Store controller indoors, in a dry, cool place.
7. Inspect wire near connectors. Check for broken or missing insulation. Check for tarnished or corroded wires. Trim corroded wires and replace connectors if necessary.

Summer Storage

1. Apply dielectric grease or similar protective compound on all electrical connectors & protect them with caps before storage.
2. Disconnect and remove speed controller from vehicle and store it in dry and cool place. Protect controller from excessive heat and moisture.
3. Clean hopper and trough from all kinds of debris.
4. Remove, thoroughly lubricate and reinstall trough bearing.
5. Protect hopper from excessive temperatures during summer storage.

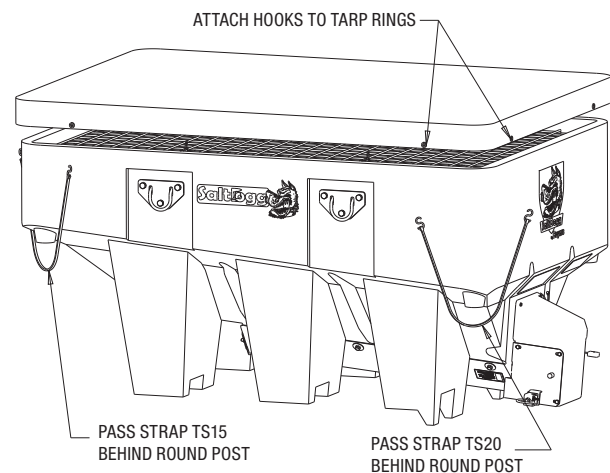

Repair Parts - Standard Chute Assembly

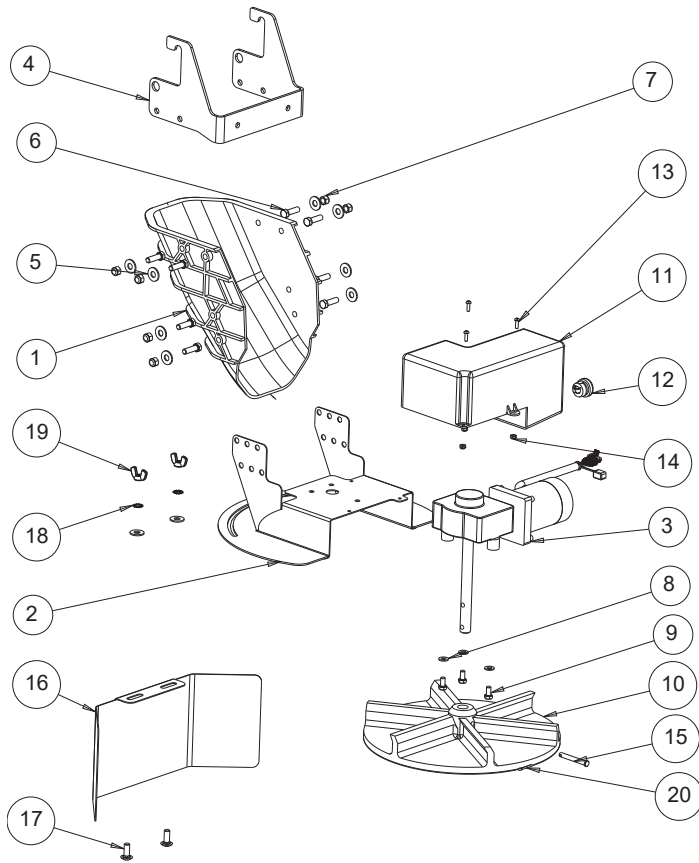

Bill of Materials

ITEM	PART NO.	QTY.	DESCRIPTION
1	3025063	1	CHUTE POLY, SHPE STD. LENGTH
2	3033665	1	BRACKET WELDMENT, CHUTE
3	3006833	1	GEAR MOTOR 12 VDC. SPINNER
4	3027699	1	HANDLE, CHUTE
5	FWF038100007SS	10	WASHER, FLAT 3/8 USS SST
6	FCS038016125SS	8	SCREW, HHC-3/8-16 X 1.25 SST
7	FNE038016044SS	8	NUT, NYLOCK 3/8-16 X 7/16 SST
8	FWF031075006SS	3	WASHER, 5/16 SAE SST
9	FCS031018063SS	3	SCREW, HHC 5/16-18 X 5/8 SST
10	3012393	1	SPINNER, 14" POLY CW
11	3025067	1	ENCLOSURE, GEAR MOTOR
12	3025065	1	BUSHING STRAIN RELIEF
13	3001537	3	SCREW, SOCBHCS #10 X 5/8 SST
14	FNE010024024SS	3	NUT, ELASTIC STOP 10-24 SS
15	3007113	1	PIN, CLEVIS, 5/16 X 2-1/2, .141 HOLE ZN
16	3017444	1	SHIELD, CHUTE
17	3014960	2	BOLT, 3/8-16 X 1 CARRIAGE SHORT NECK SS
18	3017356	2	WASHER, EXTERNAL TOOTH LOCK 3/8 SS
19	3025064	2	NUT, 3/8-16 WING, SST
20	3014994	1	PIN, COTTER, 1/8IN X 1IN SST

Repair Parts - Extended Chute Assembly

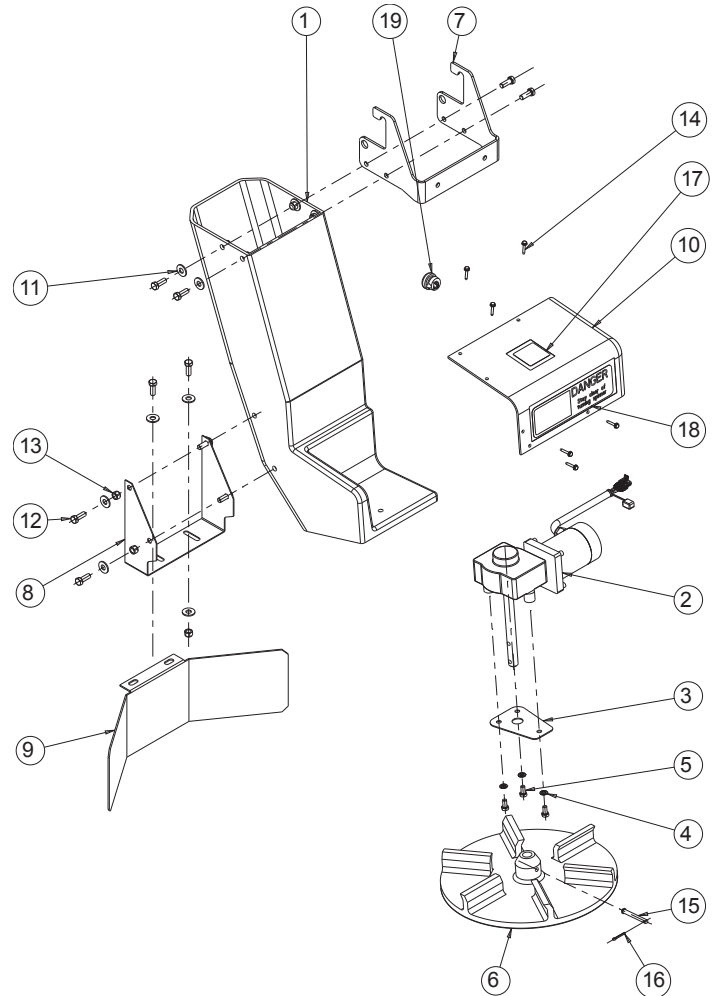

Bill of Materials

ITEM	PART NO.	QTY.	DESCRIPTION
1	3007526	1	CHUTE POLY. EXT. LENGTH
2	3006833	1	GEAR MOTOR 12 VDC. SPINNER
3	3007824	1	RETAINER GEARMOTOR, CHUTE
4	FWL031058008SS	3	WASHER, 5/16 LOCK SST
5	FCS031018063SS	3	SCREW, HHC 5/16-18 X 5/8 SST
6	3012393	1	SPINNER, 14" POLY CW
7	3027699	1	HANDLE, CHUTE
8	3007564	1	BRACKET, SHIELD SST
9	3007004	1	SHIELD, SPINNER, SHPE1500
10	3007413	1	COVER, GEAR MOTOR, CHUTE
11	FWF038100007SS	16	WASHER, FLAT 3/8 USS SST
12	FCS038016100SS	10	SCREW, HHC 3/8-16 X 1 304 SST
13	FNE038016044SS	10	NUT, NYLOCK 3/8-16 X 7/16 SST
14	3007522	6	SCREW, SHEET MTL #12x1.0 HEX WASHER HD SST
15	3007113	1	PIN, CLEVIS, 5/16 X 2-1/2, .141 HOLE ZN
16	FPC013000100	1	COTTER PIN, 1/8 X 1, ZINC
17	3002631	1	LABEL, "NO STEP"
18	3007844	1	DECAL, DANGER STAY CLEAR
19	3025065	1	BUSHING STRAIN RELIEF

Repair Parts-Hopper Assembly

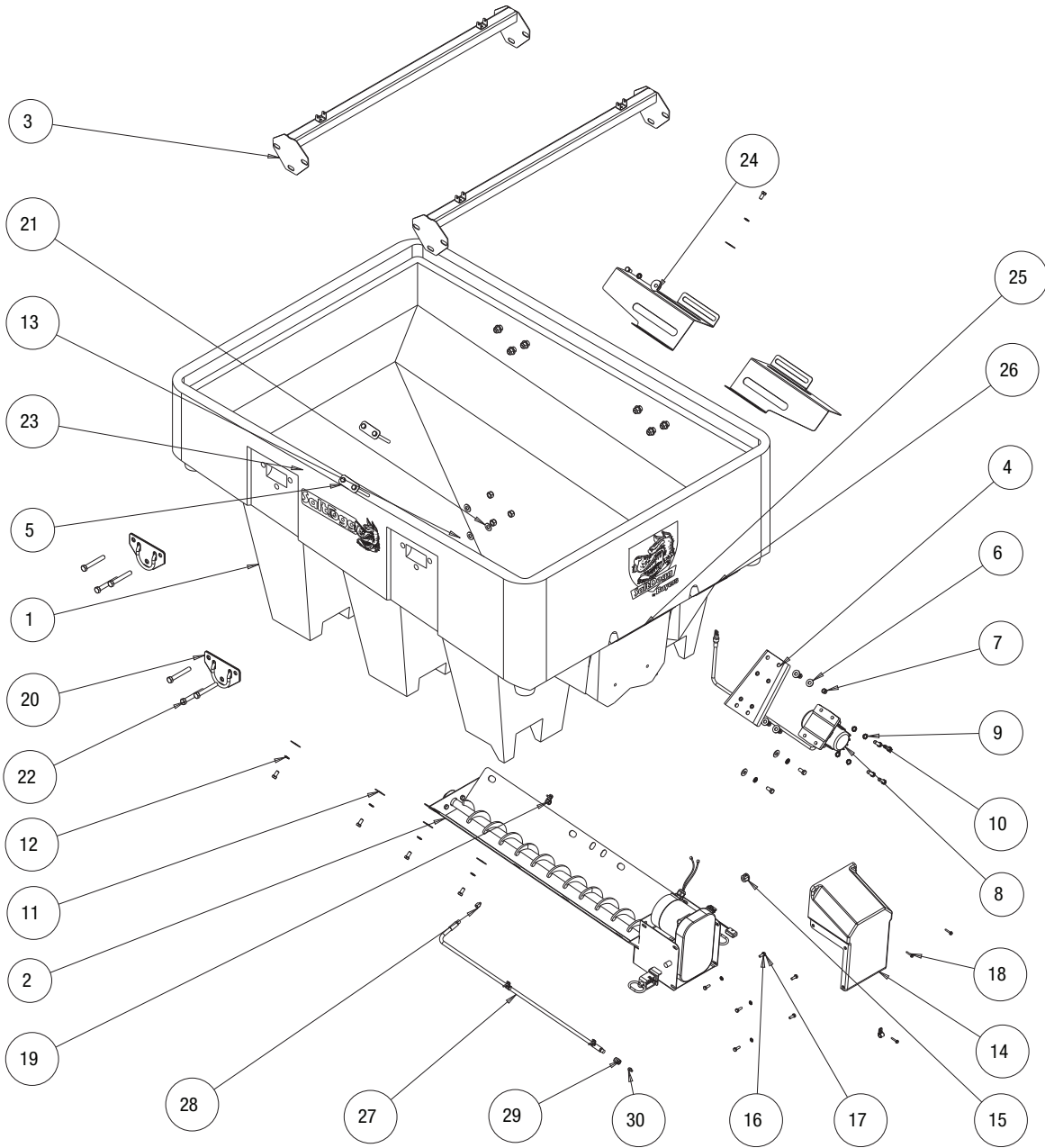

Bill of Materials

ITEM	PART NO.	QTY.	DESCRIPTION
1	3022973	1	HOPPER POLY 1 CU YA
2	3024289	1	TROUGH ASSEMBLY, SHPE
3	3022230	2	CROSS MEMBER
4	3022976	1	BRACKET VIBRATOR, WELDMENT
5	3024288	2	RETAINER VIBRATOR
6	FWF038100007SS	6	WASHER, FLAT 3/8 USS SST
7	FNE038016044SS	4	NUT, NYLOCK 3/8-16 X 7/16 SST
8	3007416	1	VIBRATOR 200 LBS 12 VDC
9	3017356	4	WASHER, EXTERNAL TOOTH LOCK 3/8 SS
10	FCS038016125SS	4	SCREW, HHC-3/8-16 X 1.25 SST
11	3007115	10	WASHER, FLAT 3/8 X 1.5 X.048 SST
12	FWL038069009SS	12	WASHER, LOCK RHS-3/8 SST
13	FCS038016075SS	12	SCREW, HHC-3/8-16 X 3/4 SST
14	3007236	1	COVER GEARMOTOR
15	3007821	1	STRAIN RELIEF BUSHING

ITEM	PART NO.	QTY.	DESCRIPTION
16	FWL025050006SS	6	WASHER, 1/4 IN. SPRING LOCK SST
17	FCS025020075SS	6	SCREW, CAP 1/4-20 X 3/4 SST
18	3007522	6	SCREW, SHEET MTL #12x1.0 HEX WASHER HD SST
19	4375	4	CLAMP, HOSE .4375, 9/32 HOLE
20	3022220	4	TIE-DOWN WELDMENT
21	FWF050106010	12	WASHER, FLAT 1/2" SAE ZINC
22	3005140	12	SCREW, HH1/2-13 x 3.5, GR 5 ZN
23	FNE050013053	12	NUT, NYLOCK 1/2-13 ZINC
24	3022977	2	DEFLECTOR
25	9240132	1	DECAL #2, DANGER BEFORE SVCE
26	3012898	1	DECAL, CHECK STRAPS
27	3022955	1	HOSEGREASE, 1/8 NPT, 36 IN LONG
28	3020713	1	CONNECTOR, MALE, FEMALE
29	H3309X2	1	CONNECTOR, FEM NPT TO FEM NPT 1/8 X 1/8
30	800	1	GREASE FITTING, 1/4 STD

Repair Parts- Trough

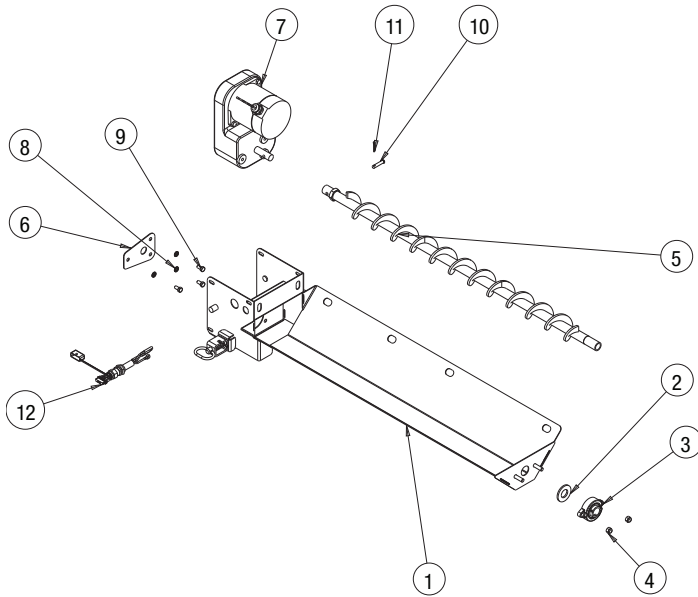

Bill of Materials

ITEM	PART NO.	QTY.	DESCRIPTION
1	3024290	1	TROUGH WELDMENT SHPE1500
2	3007000	1	GASKET, FELT BEARING
3	3018919	1	BEARING, 2-HOLE FLANGED 1" SST
4	FNE038016044SS	2	NUT, NYLOCK 3/8-16 X 7/16 SST
5	3018007	1	AUGER SHPE SST
6	3007824	1	RETAINER GEARMOTOR, CHUTE
7	3009995	1	GEAR MOTOR, AUGER SHPE
8	FWL031058008SS	3	WASHER, 5/16 LOCK SST
9	FCS031018063SS	3	SCREW, HHC 5/16-18 X 5/8 SST
10	FPY031000150	1	PIN, CLEVIS, 5/16 X 1-1/2, W/ 5/32 PH, ZN
11	3014994	1	PIN, COTTER, 1/8IN X 1IN SST
12	3006844	1	WIRE HARNESS

Service Parts and Accessories

PART NO.	DESCRIPTION
3012431	Replacement Motor for 3006833, 3027293
3021617	Replacement Coupler for 3006833, 3027293
3021616	Rocker Switch for Controller 3014199
3020624	Remote Grease Kit
LS6	Wetting System, 30 Gal.
LS6H	Wetting System, Hydraulic, 30 Gal.

Repair Parts- Spreader

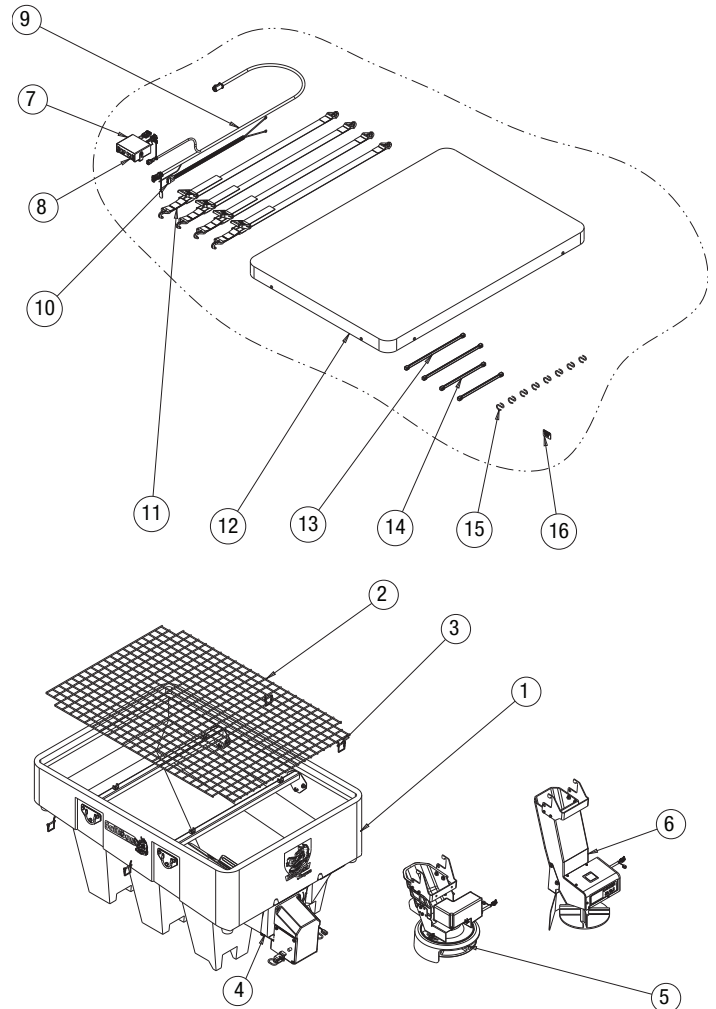

Bill of Materials

ITEM	PART NO.	QTY.	DESCRIPTION
1	3022974	1	HOPPER ASS'Y 1 CU YA
2	3022978	1	SCREEN SHPE1000
3	66050	4	SNAPPER PIN, 1/4 X 2, YLW ZINC
4	3022980	1	LABEL SERIAL NUMBER SHPE1000
5	3025070	1	CUTE ASSEMBLY. STD LENGTH
6	3007527	1	CHUTE POLY EXT. ASSEMBLY
7	3027463	1	HARDWARE KIT SHPE1000
8	3014199	1	CONTROLLER, SHPE, SALT DOGG
9	3006724	1	WIRE HARNESS, MAIN
10	3035933	1	POWER CABLE, CONTROL BOX
11	1496505	1	HOLD DOWN KIT, SPREADER (4 STRAPS)
12	3022979	1	TARP SHPE1000
13	TS20	2	STRAP, RUBBER TARP 20" (27" MAX)
14	TS15	2	STRAP, RUBBER TARP 15" (22" MAX)
15	9225	8	S-HOOK, 2.5" ZN, TARP STRAP
	3001379	1	BATTERY CABLE
	CB120PB	1	CIRCUIT BREAKER