

Installation Instructions

P45AC4 Air Compensated Pintle Hook

Rigid type pintle hook with air actuated plunger. The plunger provides minimum clearance with some shock absorption.

WARNING

Maintain adequate vertical (tongue) load to properly control the trailer (generally 10%) but do not exceed the above rated capacities.

Capacity

Weight Carrying

18000 lbs. Maximum Vertical Load

90000 lbs. Maximum Gross Trailer Weight

(120000 lbs. Tensile)

Towing Applications

Trailer, full trailers, and doubles operating within the stated capacities. Reduce capacities by 25% for off road applications and use with swivel type drawbar.

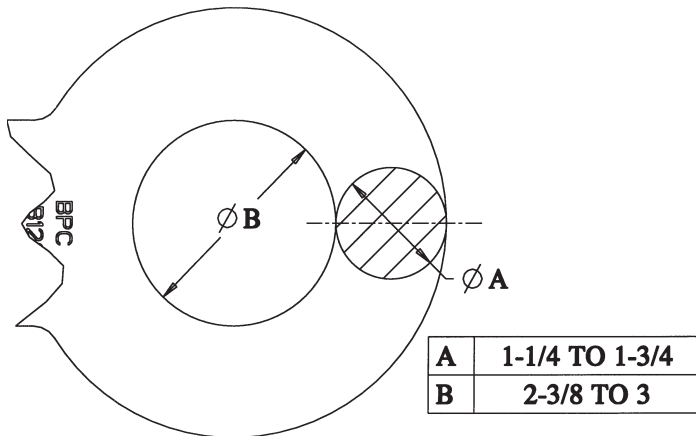

Drawbar Eye Dimensions

2-3/8" to 3" I.D. with 1-1/4" to 1-3/4" section.

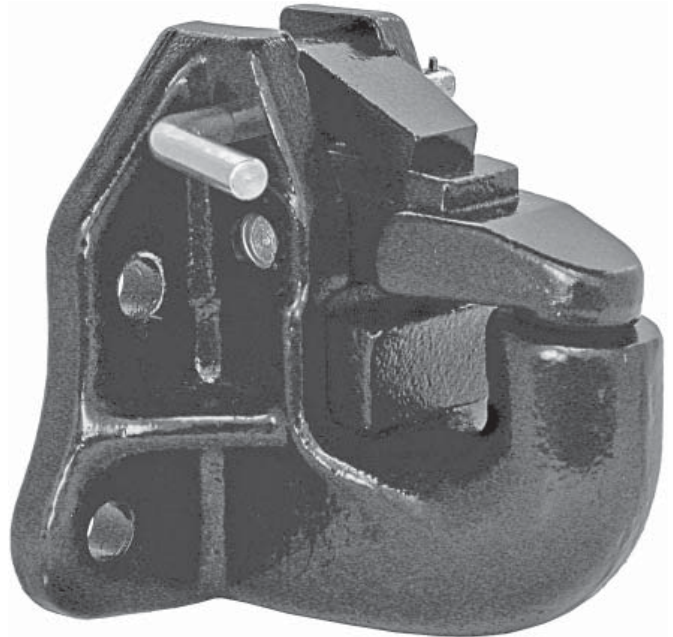

WARNING

This hitch must be used with an air brake chamber.

Mounting Instructions

In order to perform this repair, it will be necessary to remove the hook from the vehicle.

1. Use a mounting structure of sufficient strength to support the rated capacity of the pintle hook in accordance with SAE J849B.
2. Use hole pattern dimensions described in "General Dimensions"
3. Determine the cut length for the air chamber rod and cut rod (see steps 3a and 3b).

Assemble jam nut to the rod before cutting and remove after cutting to clean up any damaged threads.

3a. When using Buyers mount bracket, P45AC6BK, determine the cut length as follows:

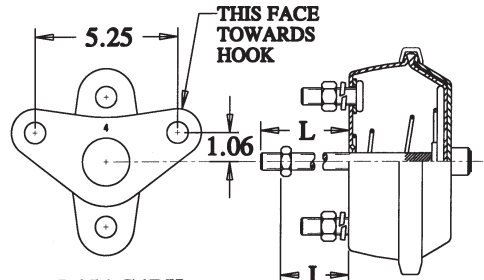

**P45AC4BK
MOUNT BRACKET**

**BC45T24
TYPE 24 CHAMBER
(SUPPLIED W/ 8" PUSH ROD)**

**PUSH-ROD LENGTH
WHEN USED WITH P45AC4BK BRACKET:**
 $L = 2.25 + T$
 $J = L - .75$
L = RETRACTED LENGTH
J = RETRACTED LENGTH TO JAM NUT
T = MOUNTING THICKNESS

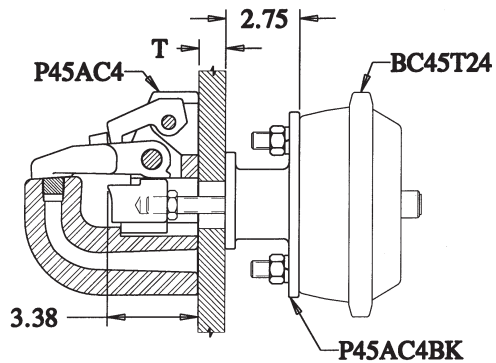
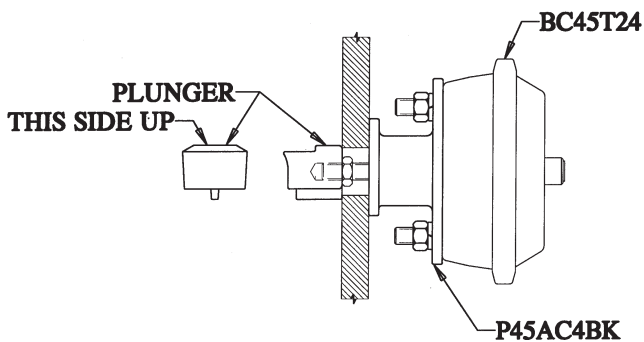

3b. When using any other air chamber mounting structure, determine the cut length as follows:

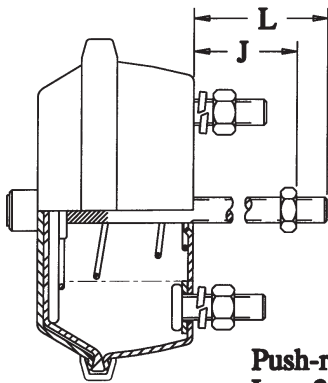

Push-rod Cut Length (retracted):
 $L = 2 + T - S$
 $J = L - .75$
L = Retracted Length
J = Retracted Length to Jam Nut
T = Mounting Thickness
S = Air Chamber Stroke

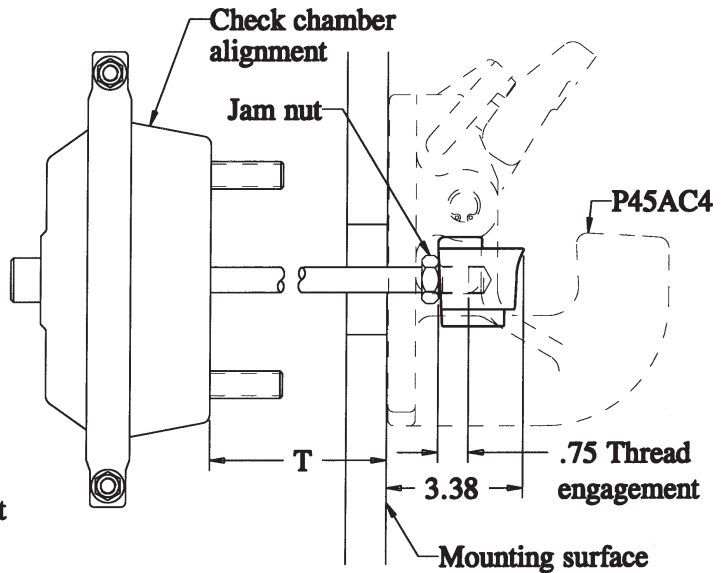

4. Assemble the air chamber to the P45AC6BK mount bracket or custom mount structure. Torque fasteners to 133-155 ft/lbs.

5. Install pintle hook four 3/4" grade 8 screws and nuts in the hitch's bottom four holes and hand tighten. Assemble thimble to the end of the chamber rod.

Assemble the air chamber assembly to hitch using the top two holes and two more 3/4" grade 8 screws. Tighten all screws properly. Torque plain screws to 375 ft/lbs.

6. Check hitch for proper operation by extending and retracting plunger.

Operating Instructions

1. Before operating, inspect hitch assembly for proper operation, worn, damaged or missing parts. Correct any flaws prior to use.
2. Verify that the plunger is retracted. Release air pressure to retract plunger, if necessary.
3. Open latch by pulling handle and rotating it upward. While holding the handle up, lift the jaw and hook it open on the lock.
4. Lower drawbar eye over the horn of the pintle.
5. Close jaw and lock. Verify that the lock slides completely into pocket.

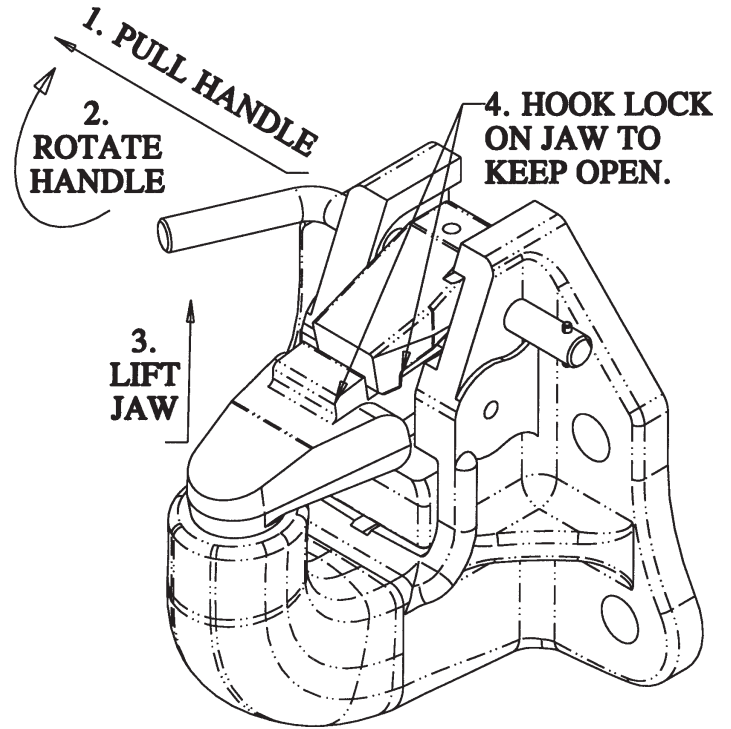

Maintenance Instructions

1. Clean and check for proper operation.
2. Inspect and replace worn, damaged or missing parts.
3. Keep all pivot points well lubricated with light oil.
4. Check mounting bolts for proper torque.
5. Check for proper plunger adjustment.

WARNING

Other steps and inspections are also required. Consult D.O.T. regulations and The American Trucking Association for complete coupling and uncoupling procedures.

General Dimensions

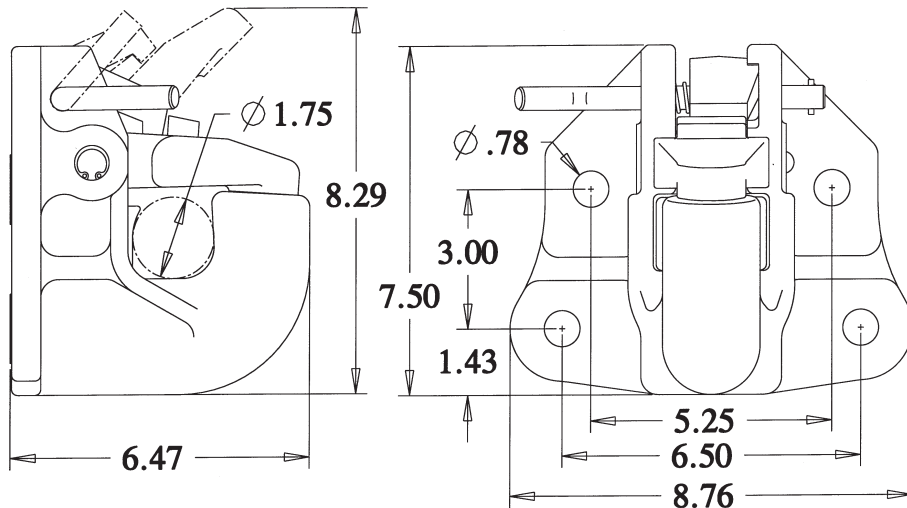

Replacement Parts Kit

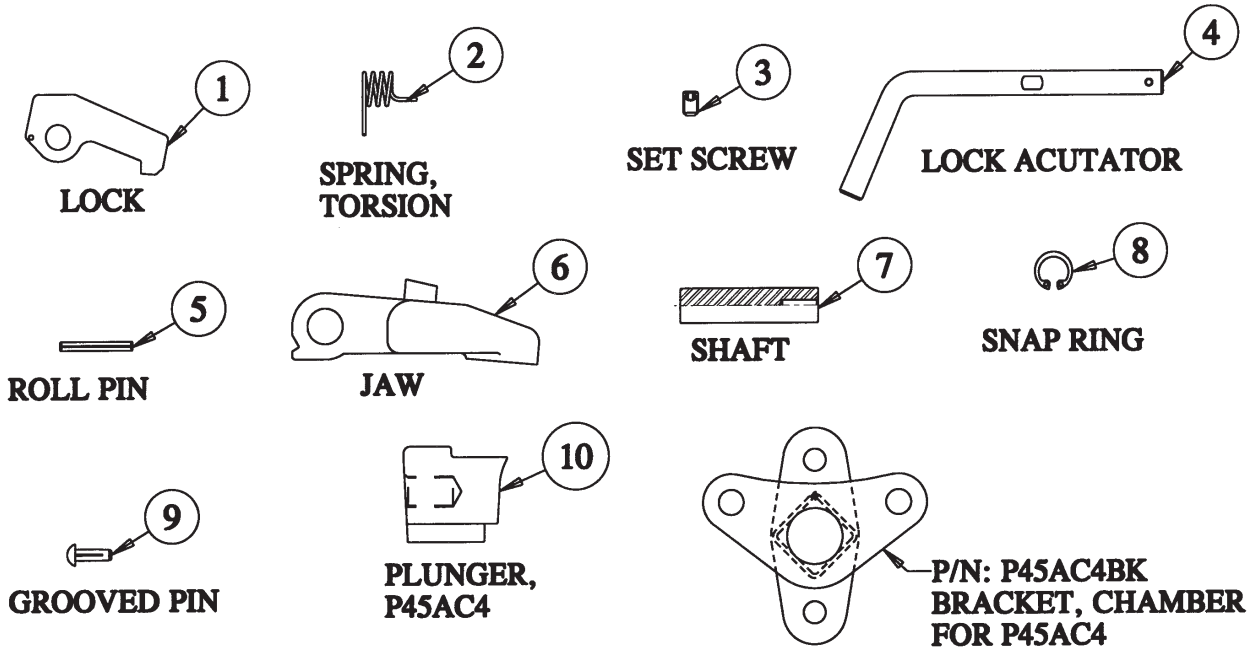

REPLACEMENT PART KITS		ITEM QUANTITY									
KIT NO:	DESCRIPTION	1	2	3	4	5	6	7	8	9	10
C4200	KIT, P45AC4 JAW REPLACEMENT	-	1	-	-	1	1	1	1	1	1
C4300	KIT, P45AC4 LOCK REPLACEMENT	1	1	1	-	1	-	-	-	-	-
C4400	KIT, P45AC4 REBUILD	1	1	1	1	1	1	1	1	1	1

Hole Pattern

Pattern drawing not to size.

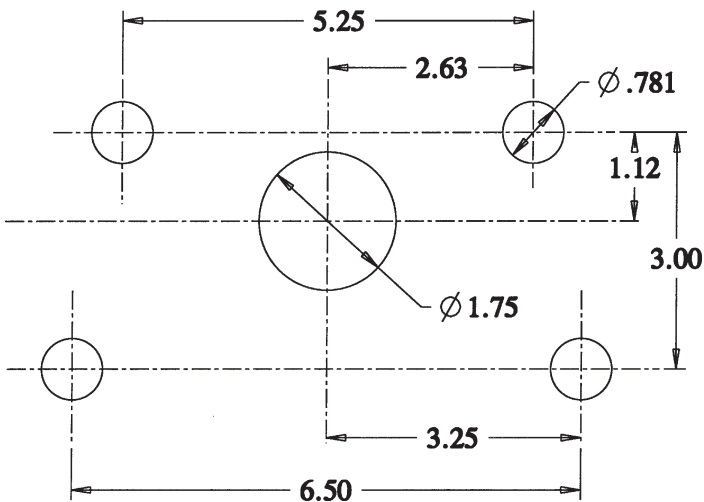

Warranty

Buyers Products Co. warrants all truck/trailer hardware manufactured or distributed by it, to be free from defects in material and workmanship for a period of one year from date of shipment. Parts must be properly installed and used under normal conditions. Any product which has been altered, including modification, misuse, accident or lack of maintenance will not be considered under warranty. Normal wear is excluded. The sole responsibility of Buyers Products Co. under this warranty is limited to repairing or replacing any part or parts which are returned, prepaid, and are found to be defective by Buyers Products Co. Authorization from Buyers Products Co. must be obtained before returning any part. No charges for transportation or labor performed on Buyers' products will be allowed under this warranty.