

Installation & Operator's Manual

LS1 Liquid Spray System

Installation Instructions

- 1.** Position pump enclosure bracket (#3028485) (see fig. 1) and pump enclosure (#WSE39) (see fig. 2) at left rear corner of hopper spreader, (see figs. 1 & 2). Make sure pump enclosure and bracket do not interfere with operation of other accessories such as the feedgate lever, engine hood, etc.
- 2.** Weld pump enclosure bracket (#3028485) in place.
- 3.** Position reservoir (#WSE26), tie bar (#3008589) (see figs. 1 & 2) and mounting brackets (#3009715) on left side of hopper between side gussets. Make sure reservoir is positioned for adequate plumbing clearance and to remove filler/breather cap. Check hopper size and style. Tank may not fit on some hoppers.
- 4.** Mark selected mounting locations, remove reservoir and weld brackets in place.
- 5.** Install reservoir on mounting brackets. Use two (#1496505) (see fig. 2) 1-3/4" x 5" ratchet tie downs to secure reservoir using provided tie down slots and hooks in mounting brackets.
- 6.** Plumb: Reservoir, ball valve, filter, pump enclosure, and spray nozzles according to plumbing schematic using supplied fittings, hose, and hose clamps. Do not use Teflon tape on threads. Use liquid thread sealant. (see fig. 5, 6, & 7).

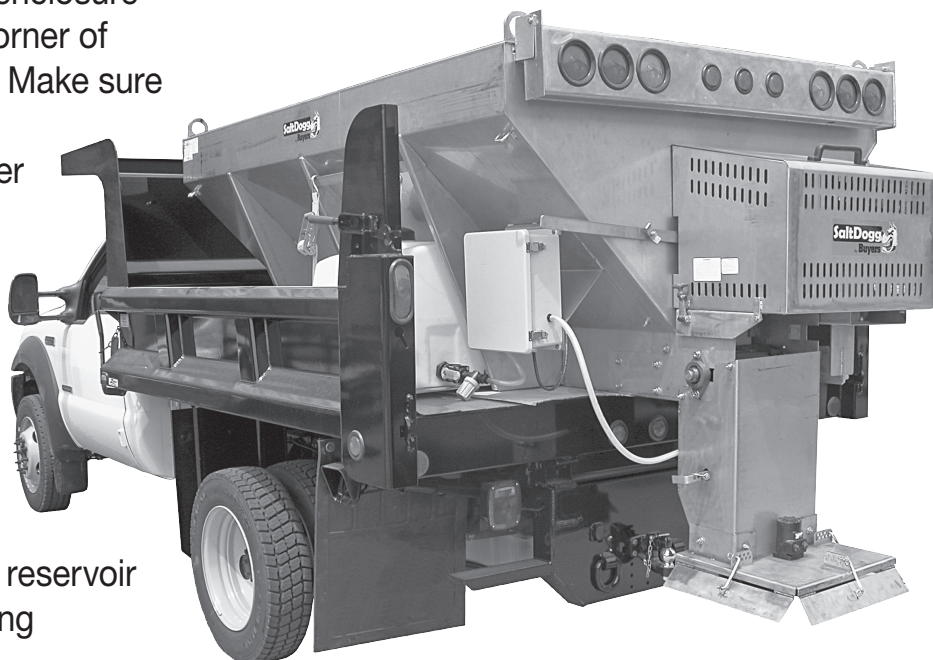

LS1 shown mounted on 1400500SSH

- 7.** Two 11/16" diameter holes are prepunched on the backside of Buyers Products mid-size spreaders for installation of two liquid spray nozzles. They are located 4" down from the back wall of the spinner chute and are spaced 7-3/4" apart on center (as shown in reference drawing). Installation on different brands of spreaders may require different nozzle locations. (see fig. 3).

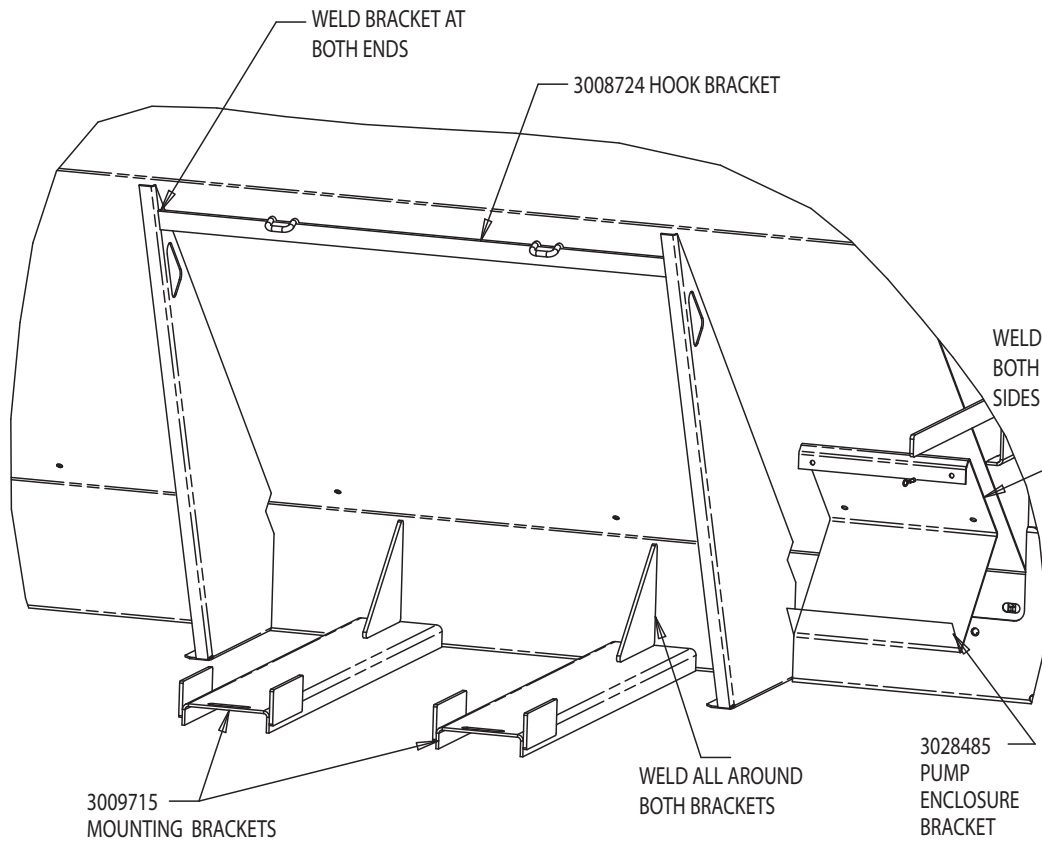

Fig. 1 Bracket Installation

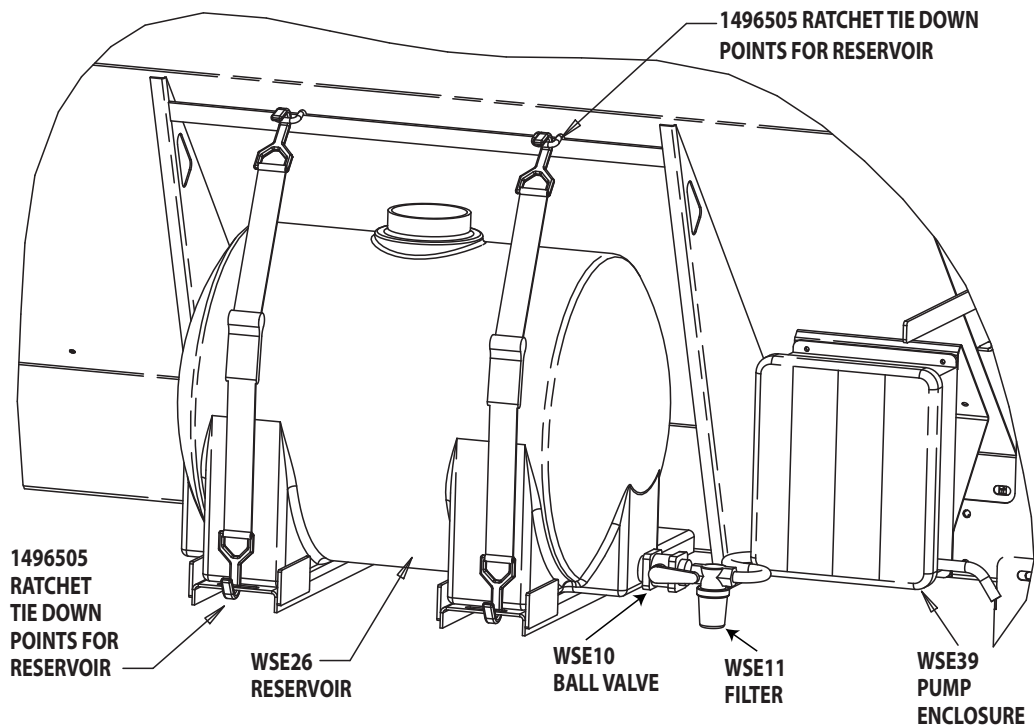
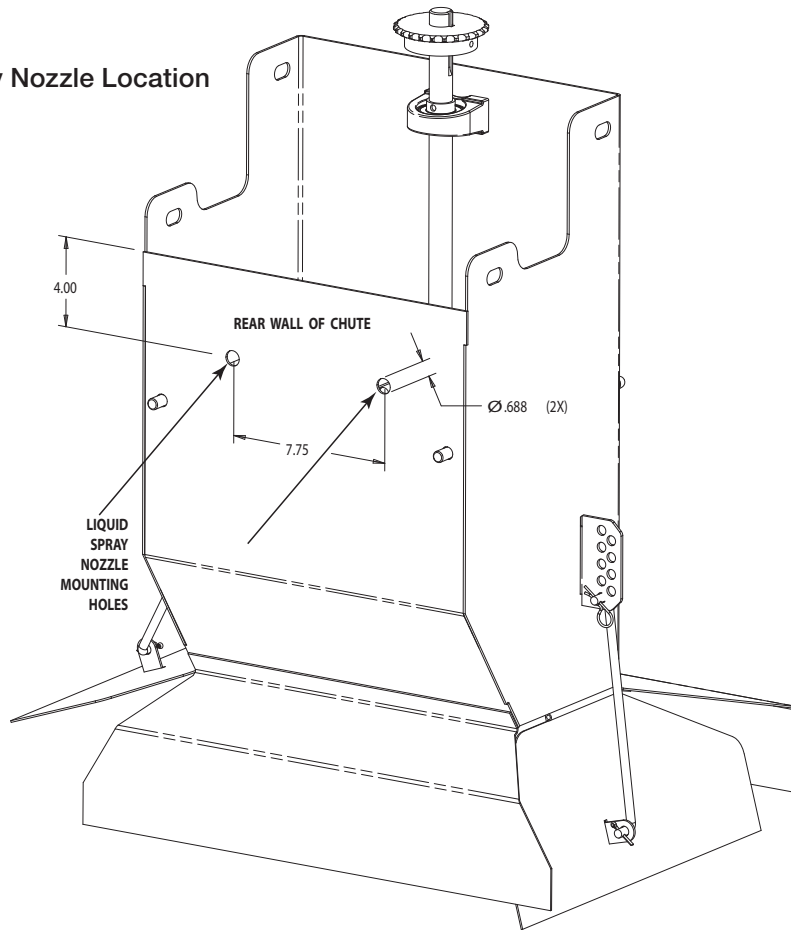

Fig. 2 Reservoir Ratchet Tie-Down Pump Enclosure Installation

Fig. 3 Liquid Spray Nozzle Location



Cab Controller Installation

Instructions (Fig. 4)

- 1.** Install cab controller (#WSE1) in cab for convenient driver operation. Mounting bracket and fasteners included.
- 2.** Route 8' wire harness (#WSE24) under dash from controller (#WSE1) to truck's fuse panel.
- 3.** Ground "black" wire from controller to truck frame or truck's battery (not dash).
- 4.** Attach "green" wire in 8' wire harness (#WSE24) to a fused and keyed 15 Amp hot wire circuit.
- 5.** Connect main power "white" wire in 8' wire harness (#WSE24) to fuse box that is "hot" full time or to battery "positive".
- 6.** Route the 25' wire harness (#WSE25) from the rear of the spreader to the cab. Plug connector on controller (#WSE1) to the connector on pump harness (#WSE25).



Fig. 4 WSE1 Cab Controller front view

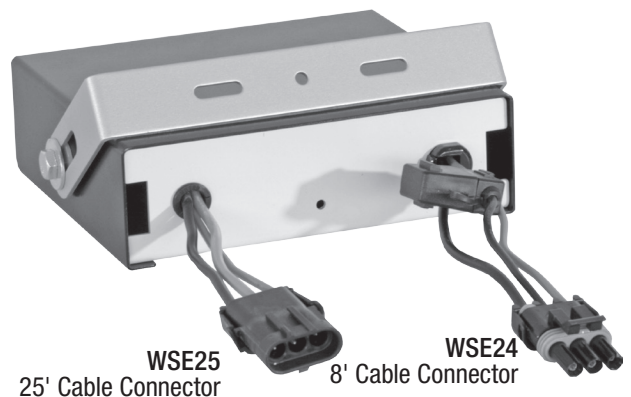

Fig. 4 WSE1 Cab Controller back view

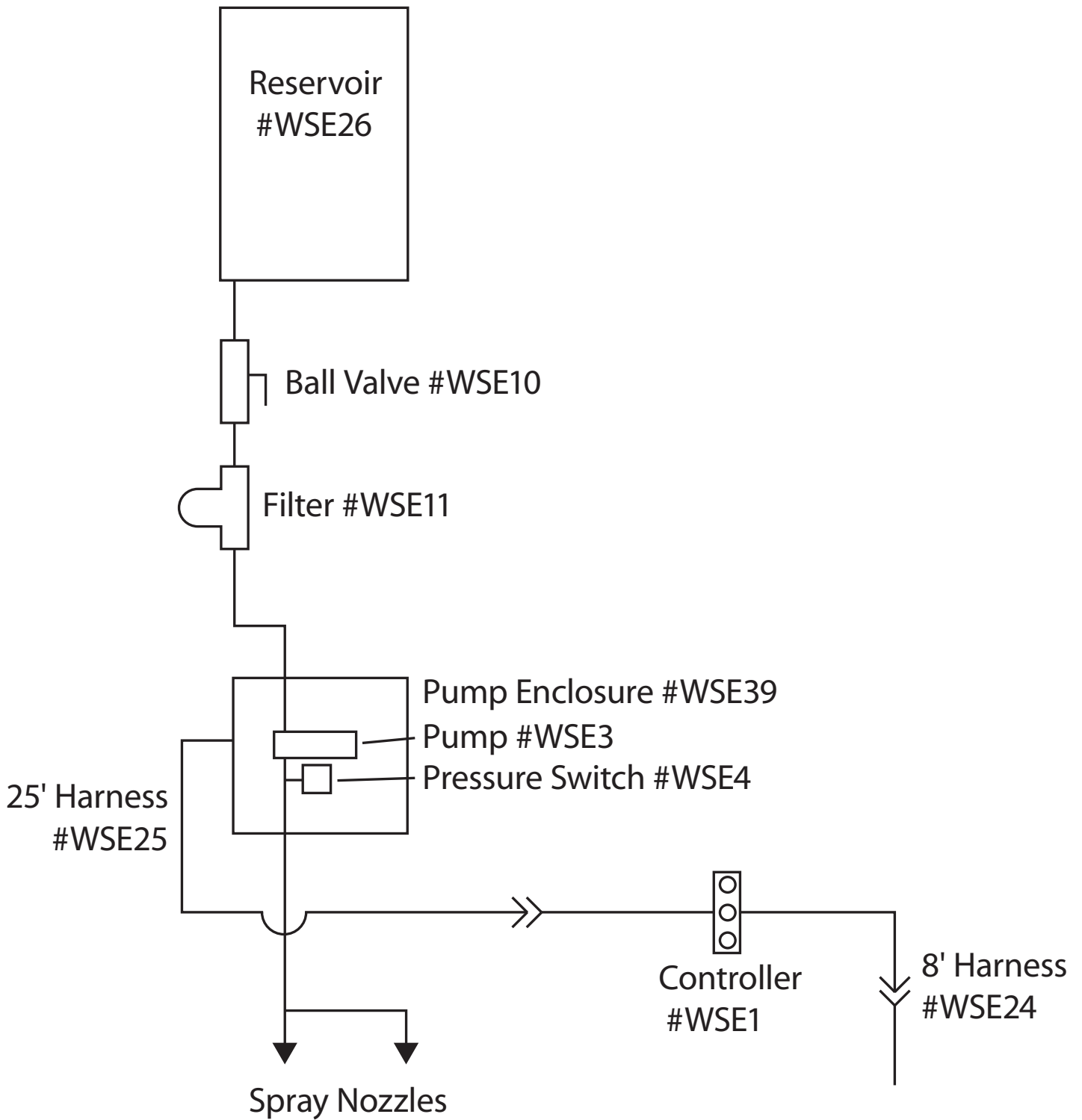

Fig. 5 Plumbing Dia.

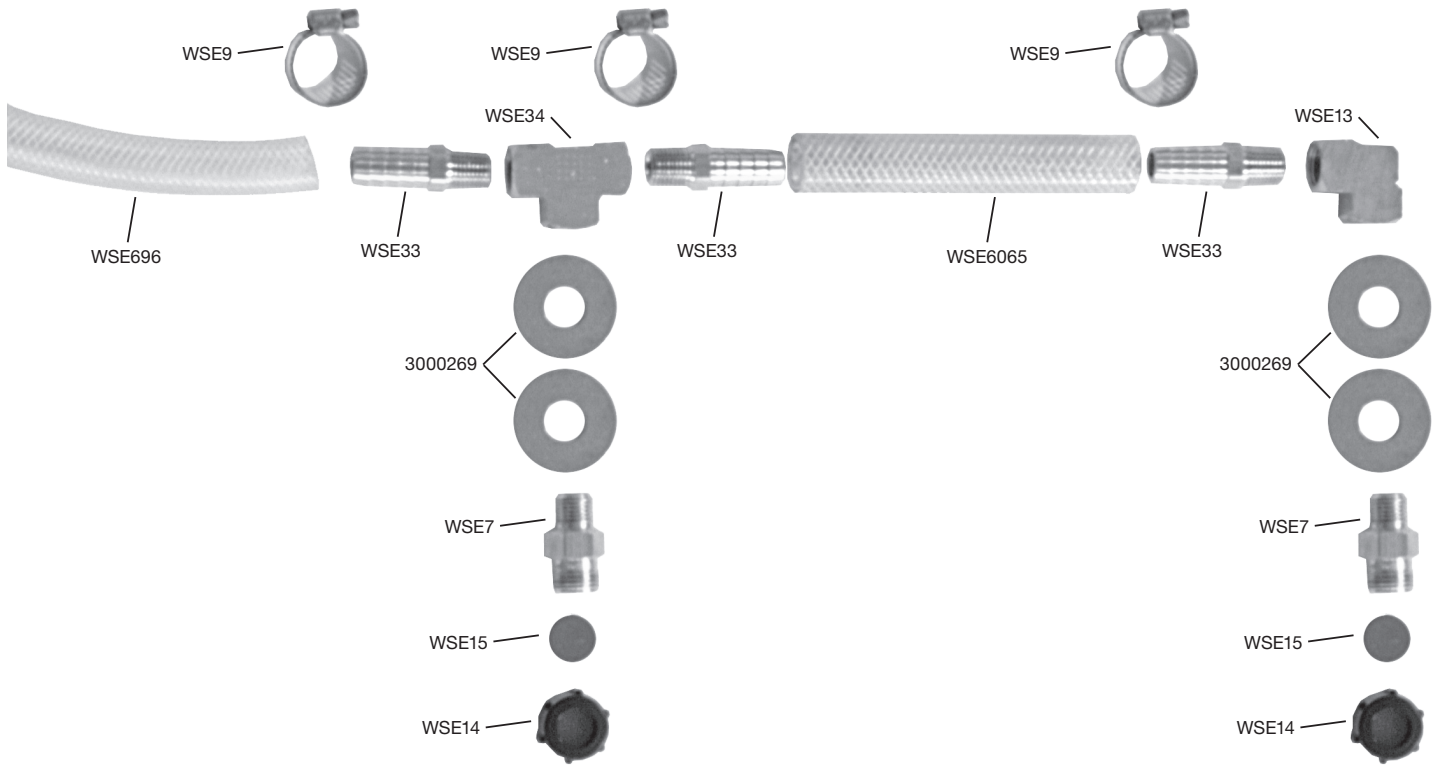

Fig. 6 Nozzle Assembly

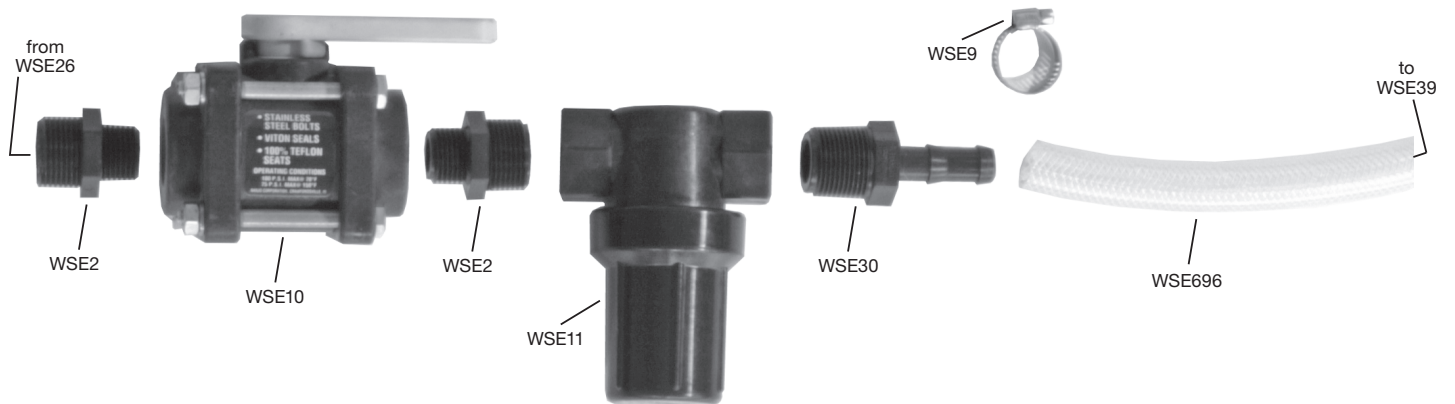

Fig. 7 Filter/Valve Assembly

Liquid Spray System Operating Instructions

1. Read all instructions before operating. Always wear hand, eye, and skin protection when working with de-icing chemicals. Make sure everyone is standing clear of liquid spray system before operating.
2. Inspect all plumbing for leaks.
3. Open ball valve (#WSE10) at the reservoir.
4. Make sure reservoir has adequate supply of clean de-icing liquid. Do not operate pump without liquid.
5. Before turning the cab controller on, turn the black speed control knob counter clockwise until it stops to set the pump at the slowest speed.
6. To energize system, turn red power button to illuminate LCD screen “on” position.
7. Increase pump speed to desired liquid spray application rate by turning black knob clockwise.
8. If the red low pressure warning light/alarm comes on, the reservoir is empty or the pump is off. Do not operate pump without liquid. *Note: Low pressure light and alarm will sound each time system is started. This is normal and occurs until sufficient pressure is achieved to open pressure switch (turning off light/buzzer).*
9. Close ball valve (#WSE10) at the reservoir when not in use.

Liquid Spray System Trouble Shooting Guide

Motor & Pump Operate Erratically: 1,2,3,4,5 (Possible Problem)
 Motor runs – Pump does not: 1,2,3,4,5,6,7 (Possible Problem)
 Motor & Pump fail to operate: 8,9,10,11,12 (Possible Problem)

POSSIBLE PROBLEM:

1. Little or no de-icer in tank/s
2. Clogged filter
3. Clogged Nozzles
4. Damaged suction hose
5. Ruptured pump diaphragm
6. Ball valve is closed at tank/s
7. Frozen parts
8. Bad electrical connection
9. Motor failure- burned/seized
10. Cab controller on-off switch not turned on
11. Bad cab controller on-off switch
12. Blown fuse in cab controller or fuse panel

REPAIR:

- Fill
- Clean
- Clean
- Replace
- Replace
- Open valve
- Thaw out
- Inspect
- Replace
- Turn on
- Replace
- Inspect/replace

CAUTION

Always wear hand, eye, and skin protection when working with de-icing chemicals. Use extreme care!

Liquid Spray System Routine Maintenance

RESERVOIR:

- Inspect fittings for leaks from cracks or looseness
- Inspect filler/breather for cracks. Depress breather to check for adequate spring pressure or binding

PLUMBING:

- Inspect hoses/fittings/ball valve for leaks, cracks, looseness, chafing, binding etc.

FILTER:

- Remove and clean filter element every 8 to 10 hours or as needed depending on how clean de-icing liquid is

PUMP-PRESSURE SWITCH & ENCLOSURE:

- Inspect wiring for wear and loose or corroded connections
- Inspect door and gasket to prevent corrosion

NOZZLES:

- Inspect operation for even spray pattern. Remove and clean as needed

CAB CONTROLLER:

- Inspect lights, switch, and flow control knob
- Inspect wire harness and connections for wear and loose or corroded connections

CLEANING:

- Wash with hot water and soap after each use

STORAGE:

- Store inside to prevent freezing
- Drain liquid de-icer from tank/s and hoses when not in use for more than two days or during extremely low temperatures
- RV anti-freeze or windshield washer fluid should be run through the system for several minutes to flush de-icer from the system to prevent component freezing especially for end of season storage

CAUTION

Always wear hand, eye, and skin protection when working with de-icing chemicals. Use extreme care!

Bill of Materials

PART NO.	QTY.	DESCRIPTION
LS102	1	Enclosure Assy., Wetting System, Electric
WSE3	1	Pump, Agriculture Electric Diaphragm
WSE4	1	Switch, Pressure N. C.
WSE6065	1	Hose, 1/2" ID, 6 1/2"
WSE9	6	Clamp, Hose
WSE21	3	Connector, Insulated Electrical Spring
WSE22	1	Enclosure
WSE18	1	Connector, Cord, 1/2", Nonmetallic
WSE27	1	Nut, Barbed Wing, 1/2"
FWF025063007	8	Washer, Flat 1/4" SAE ZN
FNE025020031	4	Nut, Elastic Stop 1/4"-20 Zinc
FCS025020125	4	Screw, Hex HD Cap, 1/4-20 x 1 1/4
WSE25	1	Harness, Wire with Connector 25' Power
WSE20	1	Bushing, Reducer 1/2" x 1/4"
WSE23	1	Barb Hose, 1/2" MPT x 1/2" HB
WSE19	1	Tee, 1/2F x 1/2F x 1/2F NPT
WSE29	1	Nut, Conduit
WSE2	2	Nipple, Hex 3/4 x 1/2 Poly
WSE7	2	Nozzle Body, Brass
WSE34	1	Tee, Female Branch 1/4 x 1/4 x 1/4

PART NO.	QTY.	DESCRIPTION
WSE10	1	Valve, Ball Polypropylene
WSE11	1	Filter
WSE13	1	Elbow, Brass 1/4 NPTF x 1/4NPTF
WSE14	2	Nozzle Cap
WSE15	2	Rubber Nozzle
3000269	4	Washer, Flat 1/2 x 1-3/8" OD Stainless
WSE24	1	Harness, Wire with Connector 8' Power
WSE30	1	Barb Hose 3/4 NPT x 1/2 HB
WSE696	1	Hose, Poly 1/2 ID x 96"
3009727	1	Instructions, LS1, LS2 Electric Wetting
3008724	2	Bracket, Welded Tank Hook
3002361	2	Bracket, Tie Down
3009715	2	Support, Prewet Tank Welded
3009713	2	Stop, Tank Guard
3009714	1	Gusset, Tank Support
3028485	1	Bracket Pump Box
WSE26	1	Reservoir, 55 Gallon for Wetting System
149650501	2	Spreader Hold Down Strap (one only)
WSE1	1	Controller, Wet Spray System
WSE33	3	Barb Hose 1/4" NPT x 1/2" I.D. Hose

SAFETY ALERT SYMBOL



This Symbol Means **ATTENTION!**
Please Read & Understand Completely
Before Operating!

EQUIPMENT INSTALLERS & OPERATORS:



TURN OFF ALL POWER BEFORE PERFORMING ANY SERVICE OPERATIONS.

- Follow Recommended Operating Procedure.
- Keep Equipment In Safe Operating Condition At All Times.
- Recognize & Avoid Hazards While Operating, Servicing and Maintaining Equipment.

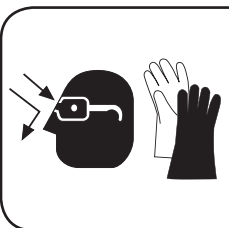

CAUTION

**RESERVOIR & COMPONENTS
MAY CONTAIN HAZARDOUS
MATERIAL.
HANDLE WITH CARE.**