

# Installation Instructions

.....

## For DTR Series Dump Tarp Kits



- 1.** Determine the location of the tarp roller. The tarp roller should be mounted above the cab on the dump body's cab guard. To prevent damage from loads being dumped into the body, the tarp roller should be mounted outside of the dump body's load area. Also, verify the location is accessible for winding the tarp up.
- 2.** Clamp the bearing bracket assemblies (item 4&5) to the dump body in the locations determined in step 1. The bearing bracket assembly with the detent lever (item 5) is to be mounted on the driver's side of the dump body. Make sure the brackets are aligned vertically as well as from front to back by measuring from a common point on each side of the body. Verify the bearing bracket assemblies are mounted high enough to accommodate the tarp when rolled onto the roll bar assembly.
- 3.** Mark the bearing bracket mounting hole's locations onto each side of the dump body. Remove the brackets and drill 13/32" holes in the four

marked locations.

- 4.** Assemble the bearing brackets to the dump body using the four 3/8-16 x 1 cap screws, lock washers and nuts supplied. Do not tighten fasteners at this time, just hand tighten to hold brackets in position.
- 5.** Locate the inner hex tube (item 1) and make a pencil mark in the center of the tube's length. Insert the inner hex tube half way into the driver's side roll tube assembly (item 2). Insert the passenger's side roll tube assembly (item 3) onto the opposite end of the inner hex tube. Measure the distance between the inside of the mounted bearing brackets (for measurements less than 81.75": The driver's and passenger's side roll tube assemblies (items 2 & 3) will need to be shortened by an equal amount to obtain the proper width). Separate the roll tubes, so the length of the complete roll tube assembly from adaptor to adaptor is 1/4" less than the distance between mount brackets. Locate the pencil mark, and verify

—continued inside

that the inner hex tube is centered inside the outer roll tube assemblies. Screw each roll tube assembly to the inner hex tube using one ¼" x 1" self drilling and tapping screw (item 9A) 2" from the end of the outer tube.

**6.** Slide the complete roll tube assembly into the 5" loop in the end of the tarp. Verify that the webbing in the seams of the tarp will be on the bottom when installed. Note: The roll tube end of the tarp only has one row of webbing reinforcement.

**7.** Center the roll tube assembly in the tarp. Holding the roll tube assembly tightly in the end of the pocket, screw in place with five evenly spaced ¼" x 1" self-drilling tapping screws (item 9A) and fender washers (item 9B). Make sure the screws are centered in the hex tube and the screws on each end are at least 2" from the end of the roll tube assembly. Be careful not to screw into the shaft adaptors (item 2B) on each end.

**8.** Remove one of the bearing bracket assemblies and slide the tarp roll assembly in to the remaining bearing. Slide removed bearing bracket over shaft and reassemble to the dump body. Tighten 3/8" bracket mounting bolts at this time.

**9.** Center the tarp roll assembly between the mounting brackets and tighten set screws in each bearing race.

**10.** Assemble sprocket (item 6) onto the 1" shaft of the driver's side roll tube assembly (item 2). With the detent lever (item 5C) in the open position, slide the sprocket down the shaft until it is tight against the bearing.

**11.** Assemble crank handle assembly (item 7) onto the driver's side roll tube shaft using the 1/4" X 2" screw and lock nut provided.

**12.** Assemble the four S-hooks (item 12) to the two tarp straps (item 11). The small end of the s-hook is assembled into the hole in the strap and should be bent around the strap to permanently attach the hook to the strap. The two strap assemblies should be attached to the rear corner holes in the tarp. The large hooks should be bent around the tarp grommets to permanently attach straps to tarp. (See figure 1.)

**13.** Assemble pull rope assembly to the center grommet on the rear of the tarp. (See figure 3.)

**14.** Assemble two rope storage hooks to the dump body tailgate to wrap the pull rope for storage when tarp is covering the body. The hooks should be mounted horizontally and may be bolted (bolts not included) or welded to the dump body. The recommend distance between the hooks is 15-17". (See figure 3.)

**15.** Assemble two rope storage hooks to the side dump body near the crank handle assembly to wrap the pull rope for storage when tarp is retracted. The hooks should be mounted vertically and may be bolted (bolts not included) or welded to the dump body. (See figure 2.)

## **Optional Accessory**

### **DTB102 Optional Retention Bow Kit Installation**

**Note: For tarps narrower than 6 feet the center tube (item 14A) will need to be shortened and re-drilled.**

**1.** Assemble outer bars (item 14B) to the center tube (item 14A) using the two 5/16" x 1" roll pins (item 14F) supplied.

**2.** Slide rear bar assembly into the pocket in the rear of the dump body tarp. Center the bar in the tarp. The same amount of bar should be exposed on each side of the tarp.

**3.** Assemble a lock collar (item 14E), guide washer (item 14D), PVC roller tube (item 14C), and second lock collar, in that order, onto each end of the rear bar assembly.

**4.** Measure the inside width of the top of dump body or bed extension boards where the guide washers will slide in between. Adjust and tighten the lock collars so that the guide washers are held ½" narrower than the body measurement. Make sure that the PVC roller tubes can spin freely on the rear bar

**5.** After the rear bar is adjusted to fit the body, the excess bar may be cut off to limit the amount of bar protruding outside the body. If the rear bars are cut, the cut ends should be painted to prevent premature rusting.

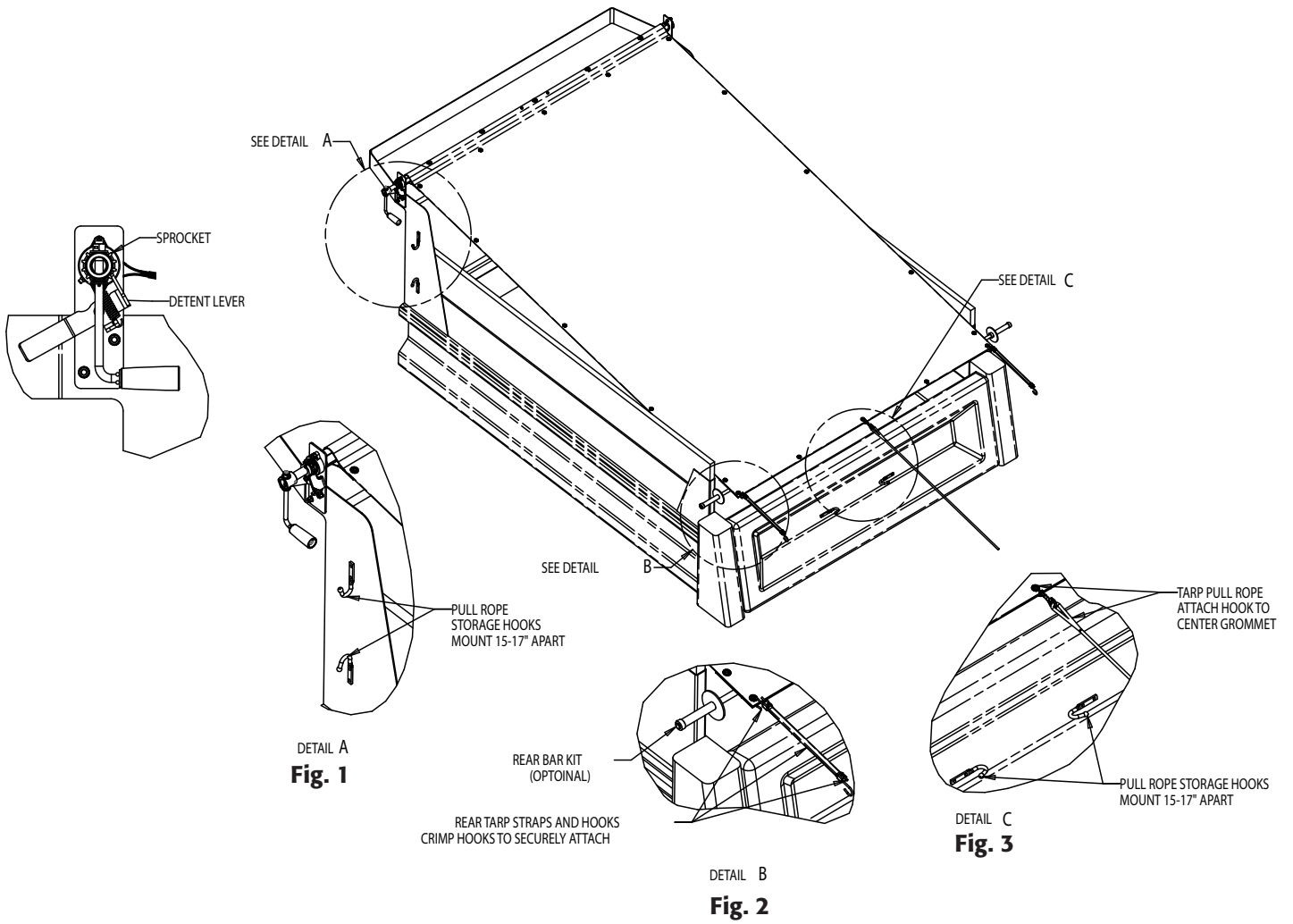

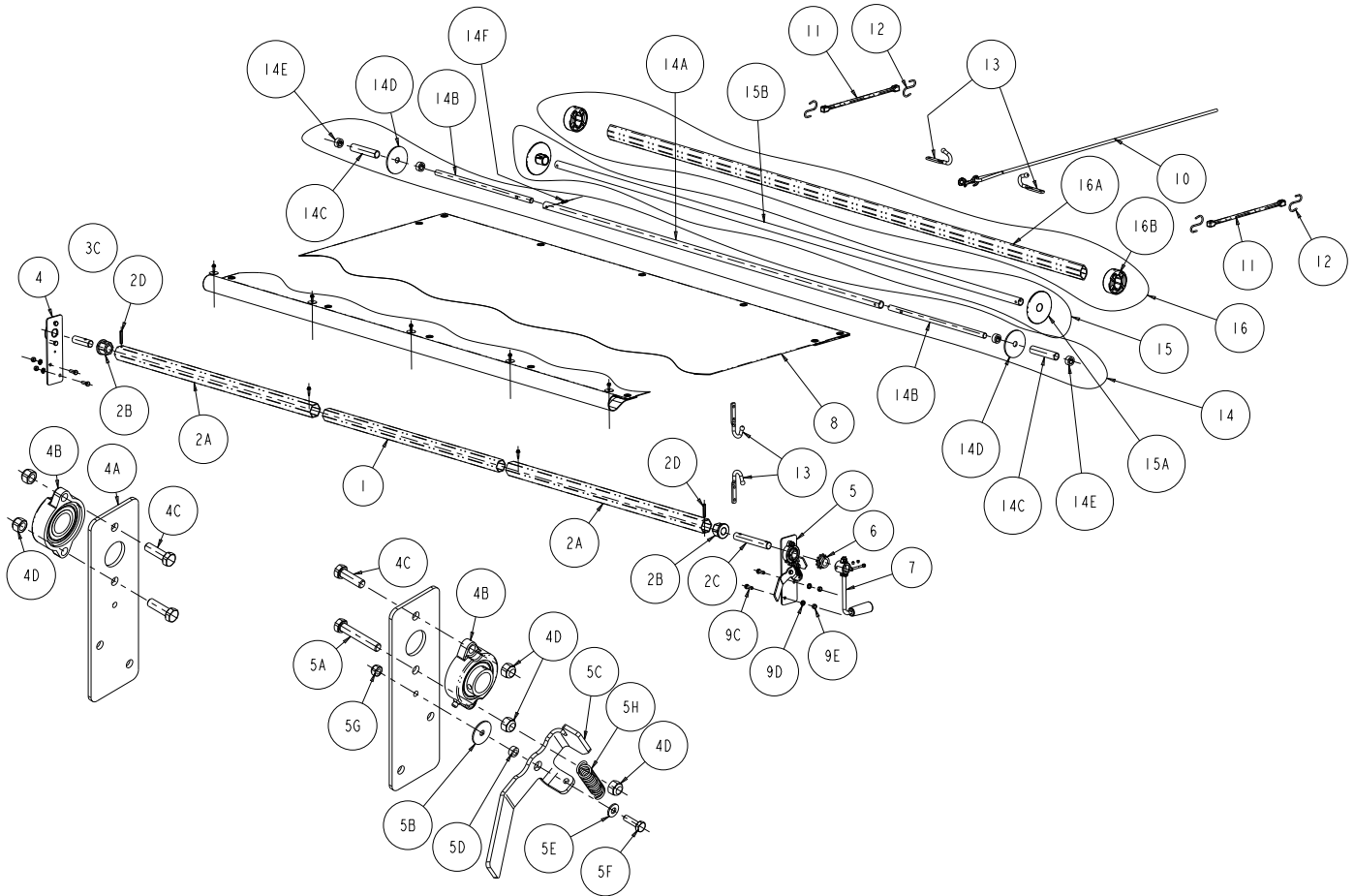

## Dump Body Tarp Roller Parts List

ITEM	PART NO.	QTY.	DESCRIPTION
1	<b>3007954</b>	1	<b>Tube, Inner Hex</b>
2	<b>3008238</b>	1	<b>Roll Tube Assy., Driver's Side</b>
2A	3007955	2	Tube, Outer Hex
2B	3008010	2	Adaptor, Shaft
2C	3008182	1	Shaft, Crank End
2D	3008191	2	Pin, Spring Roll, 5/16" x 1-7/8"
3	<b>3008239</b>	1	<b>Roll Tube Assy., Passenger's Side</b>
3C	3008181	1	Shaft, Idler End
4	<b>3008237</b>	1	<b>Bearing Bracket Assy.</b>
4A	3009425	2	Bracket, Tarp Roll Mount
4B	1411000	2	Bearing, 1" Self-Aligning
4C	FCS038016125	3	Cap Screw, 3/8-16 x 1 1/4", Zinc
4D	FNE038016044	5	Hex Nut, Locking, 3/8-16, Zinc
5	<b>3009501</b>	1	<b>Bearing Bracket Assy., Detent</b>
5A	FCS038016225FT	1	Cap Screw, 3/8-16 x 2 1/4", Full Thd., Zinc
5B	3009561	1	Washer, Nylon
5C	3009433	1	Detent Lever
5D	4100S	1	Spacer Busher
5E	FWF025063007	1	Flat Washer, 1/4", Zinc
5F	FCS025020088	1	Cap Screw, 1/4" x 7/8", Zinc
5G	FCS025020088	1	Nut, Lock, 1/4" Zinc
5H	3009434	1	Extension Spring
6	<b>1411915</b>	1	<b>Sprocket, 12 Tooth</b>
7	<b>3008176A</b>	1	<b>Crank Handle Assy.</b>
8	-	1	<b>Replacement tarps*</b>
9	<b>3008223</b>	1	<b>Hardware Bag, Tarp Roller Kit</b>
9A	3008222	7	Screw, 1/4" x 1" Self-Drilling & Tapping Zn

ITEM	PART NO.	QTY.	DESCRIPTION
9B	3008221	5	Fender Washer, 1/4" ID x 1 1/4" OD, Zinc
9C	FCS038016100	4	Cap Screw, 3/8-16 x 1", Zinc
9D	FWL038	4	Lock Washer, 3/8", Zinc
9E	FNH038016028	4	Hex Nut, 3/8-16, Zinc
10	<b>3008225</b>	1	<b>Pull Rope Assy., 20'</b>
11	<b>TS15</b>	2	<b>Tarp Strap, 15" Rubber</b>
12	<b>9225</b>	4	<b>S-Hook, Tarp Strap</b>
13	<b>B2448B</b>	4	<b>Hook, Rope Storage</b>

### Optional Accessories

ITEM	PART NO.	QTY.	DESCRIPTION
14	<b>DTB102</b>	-	<b>Rear Bar Kit</b>
14A	3008306	1	Center Tube, Rear Bar Kit
14B	3008307	2	Outer Bar, Rear Bar Kit
14C	3008308	2	PVC Roller Tube, Rear Bar Kit
14D	3008309	2	Guide Washer, Rear Bar Kit
14E	3013330	4	Lock Collar, 20 mm
14F	3006487	2	Pin, Spring Roll, 5/16" x 1"
15	<b>DTB96</b>	-	<b>Retention Bow Kit 96"</b>
15A	3023812	2	Hub
15B	3023802	1	Rod
16	<b>DTB98A</b>	-	<b>Retention Bow Kit, 98" Aluminum w/ End Collars</b>
16A	3011869	1	Tube
16B	3012786	2	Bumper