

CONTENTS

Pre-Installation	1
Vehicle Roof Installation	2
Standard Feet	2
■ Permanent Mount	3
■ Strap Kit Mount	4
Adjustable Feet	5
Flat Surface Installation	6
Narrow Surface Mount	6
Wide Surface Mount	7

PRE-INSTALLATION

To prevent damage to lightbar and vehicle, ensure that all equipment operates properly, and carefully plan where to mount and wire the lightbar and controlling equipment:

1. Verify that the lightbar and mounting hardware fit the vehicle.
2. Pre-configure desired lightbar functions.
3. Determine:
 - the location to mount the lightbar.
 - the location to route the lightbar's Power Cable.
 - the location to route the Function Cable, (eg. to siren, switch box, console).

WARNING: Take extreme care when routing wires around airbag areas to not interfere with it's proper operation.

4. Separate all electronic equipment wiring from two-way radio equipment wiring.
5. To avoid interference, keep two-way radio antennas a minimum of 50cm away from warning equipment.
6. After drilling holes, deburr and smooth sharp edges, and insert grommets to protect the wires from chafing.
7. When frame-ground the equipment, use the manufacturer-supplied ground locations in the vehicle.

VEHICLE ROOF INSTALLATION

STANDARD FEET

Install Mounting Feet on the Lightbar

1. Turn the lightbar upside down.
2. Place mounting feet over the carriage bolts.
3. Attach a lockwasher and a nut on each of the carriage bolts, but do not completely tighten the bolts. Leave them loose enough to reposition the mounting foot.

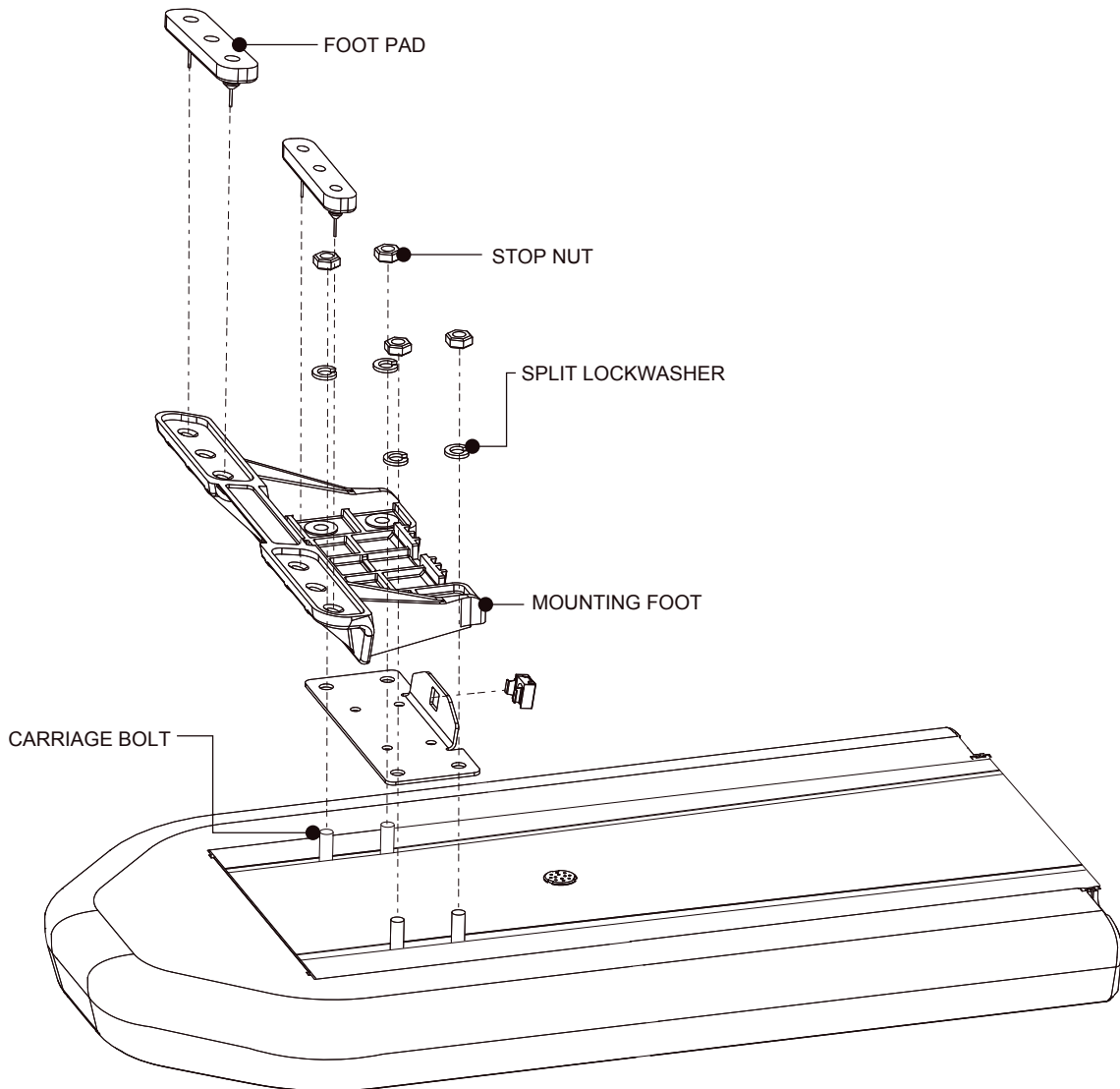

Upside down view of lightbar with mounting foot

PERMANENT MOUNT

Installation includes centering the lightbar on the vehicle's roof, leveling the lightbar, and scribing and drilling holes for mounting the lightbar permanently to the roof.

1. Place lightbar on the vehicle roof at the desired location. The lightbar is usually centered on the door center post (B-pillar).
2. Adjust both mounting feet in or out as necessary until the foot pads rest near the edge of the roof or gutter where the roof is the most rigid. Make sure the lightbar and the mounting feet are centered left to right on the vehicle.
3. Level the lightbar by shifting the lightbar slightly forward or back.
4. Using the mounting feet asa template, mark two drilling holes on each end of the vehicle roof.
5. Carefully remove the lightbar and turn it upside down, and ensure that the mounting feet do not shift place.
6. Tighten the nuts that secure the mounting feet to the lightbar.
7. Drill four holes at the previously marked drilling positions.

WARNING: DO NOT DRILL THROUGH the roof support structure that spans the distance between the driver's and passenger's side. Drilling through this will weaken the roof of the vehicle.

NOTE: Before drilling holes, ensure that the holes will go through sheet metal and not the upholstery. And ensure that no damages are caused to the vehicle components.

8. Place lightbar on the vehicle roof and align the mounting holes with the mounting feet. Secure mounting feet to vehicle roof with carriage bolts.

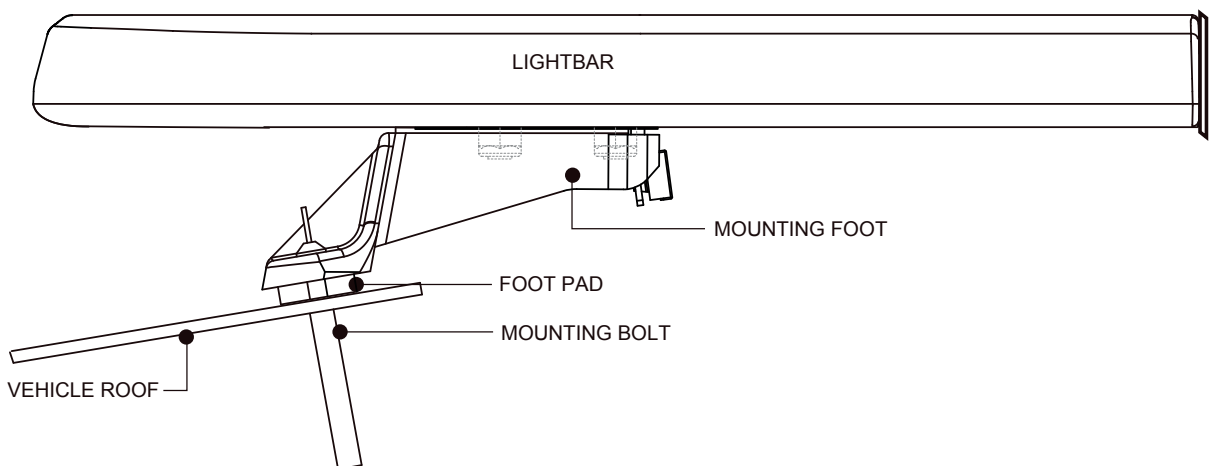

Front view of lightbar with Permanent mount

NOTE: After installation, frequently inspect the lightbar and mounting feet to ensure that all fasteners and brackets are tight.

STRAP KIT MOUNT

The Strap Kit is designed for specific make and mode of vehicle. Before installation, ensure that the correct strap kit is used.

1. Place the lightbar on the vehicle roof at the desired location. Usually, the lightbar should be centered on the center door post (B-pillar).

NOTE: Water may leak into the vehicle interior if the straps are improperly positioned. Ensure that the straps are positioned above or near the center door post (B-pillar).

2. Determine where the straps will attach to the vehicle.

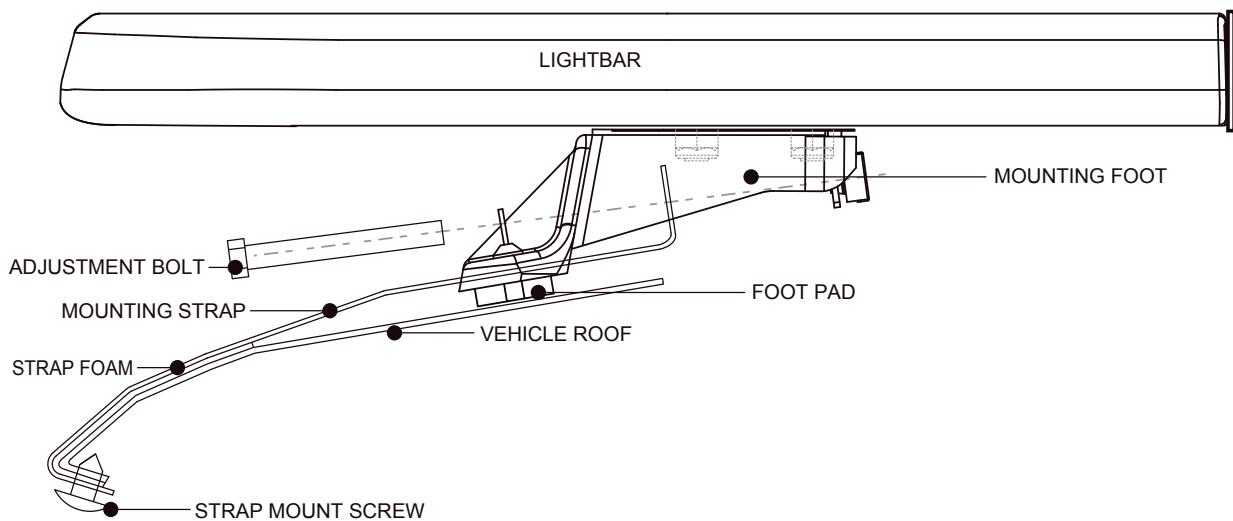

Front view of lightbar with Strap Kit mount

3. Place the straps in position on the roof sheet metal as shown in diagram.
4. Use the straps as a template and mark the drilling hole locations.
5. Drill holes according to the marked locations.
6. Apply a silicone sealant (user-supplier) around the holes before attaching the straps.
7. Secure the straps with the sheet metal screws.

NOTE: After installation, frequently inspect the lightbar and mounting feet to ensure that all fasteners and brackets are tight.

8. Place the lightbar on the vehicle roof, and align strap bolt holes with lightbar mounting feet bolt holes.
9. Insert adjustment bolt through strap bolt hole all the way to mounting feet bolt hole.
10. Tighten bolts.

ADJUSTABLE FEET

Install Mounting Feet on the LigLightbar

1. Turn the lightbar upside down.
2. Place mounting feet over the carriage bolts.
3. Attach a lockwasher and a nut on each of the carriage bolts, but do not completely tighten the bolts. Leave them loose enough to reposition the mounting foot.

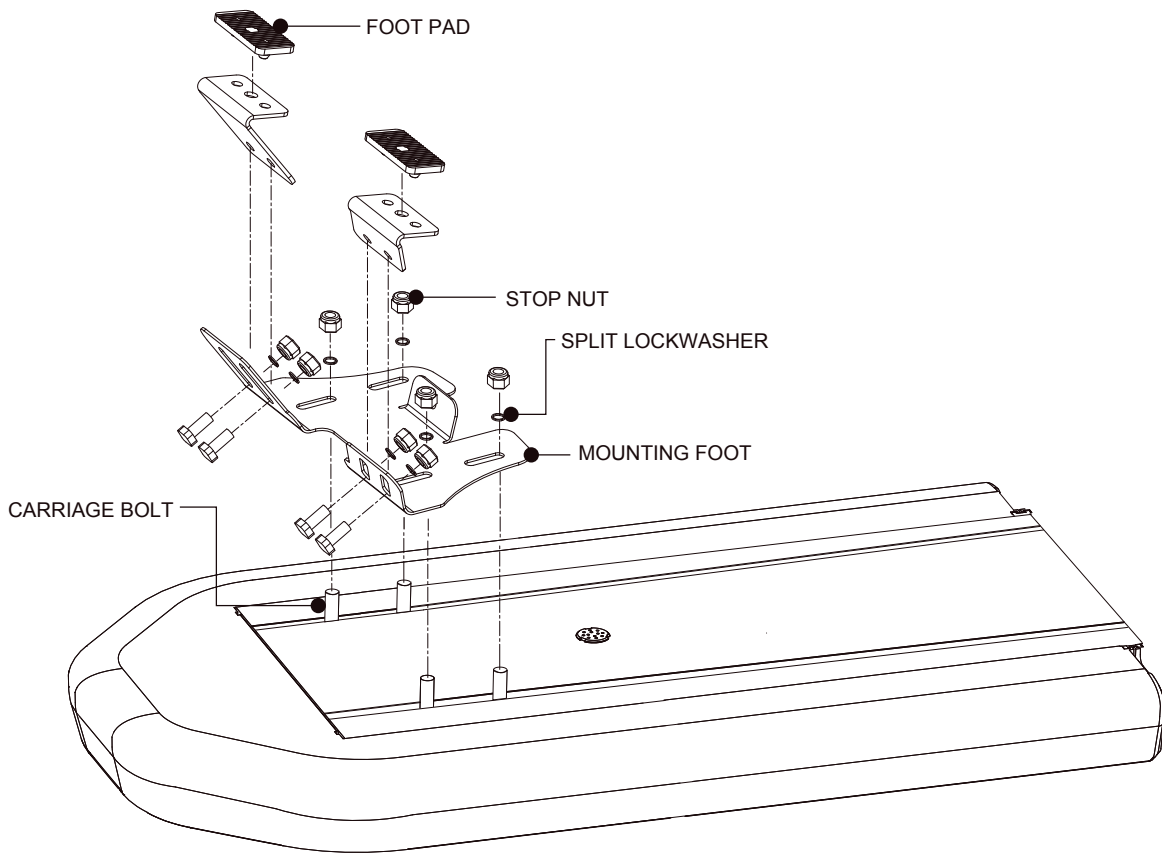

Upside down view of lightbar with mounting foot

FLAT SURFACE INSTALLATION

NARROW SURFACE MOUNT

1. Turn the lightbar upside down.
2. Place mounting feet over the carriage bolts.
3. Attach a lockwasher and a nut on each of the carriage bolts, but do not completely tighten the bolts. Leave them loose enough to reposition the mounting foot.

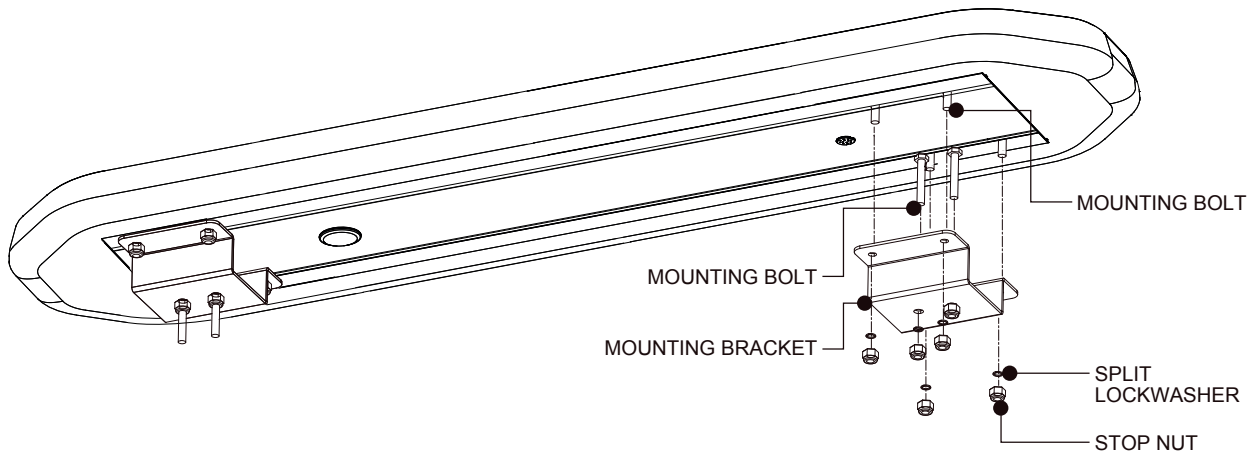

Hardware for Narrow Surface Mount

4. Place lightbar on the mounting surface at the desired location.
5. Adjust both mounting foot assemblies in or out as necessary. If possible, try to keep mounting feet near the ends of the lightbar.
6. Using the mounting feet as a template, mark two drilling holes on each end of the mounting surface.
7. Carefully remove the lightbar and turn it upside down, and ensure that the mounting feet do not shift place.
8. Tighten the nuts that secure the mounting feet to the lightbar.

NOTE: Before drilling holes in ANY part of the vehicle, be sure that both sides of the mounting surface are clear of parts that could be damaged, such as brake lines, fuel lines, electrical wiring, or other vital parts.

9. Drill four holes at the previously marked drilling positions.
10. Place lightbar on the mounting surface and align mounting holes with the mounting feet.
11. Secure mounting feet to mounting surface with carriage bolts.

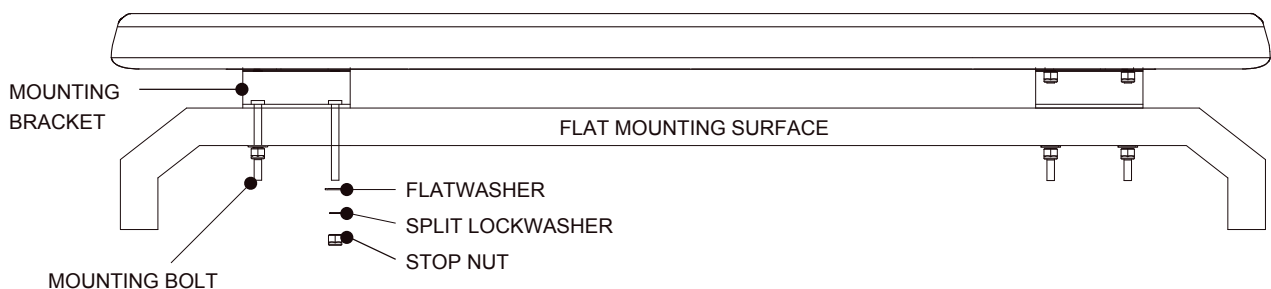

Lightbar mounted on flat narrow surface

WIDE SURFACE MOUNT

1. Turn the lightbar upside down.
2. Place mounting feet over the carriage bolts.
3. Attach a lockwasher and a nut on each of the carriage bolts, but do not completely tighten the bolts. Leave them loose enough to reposition the mounting foot.

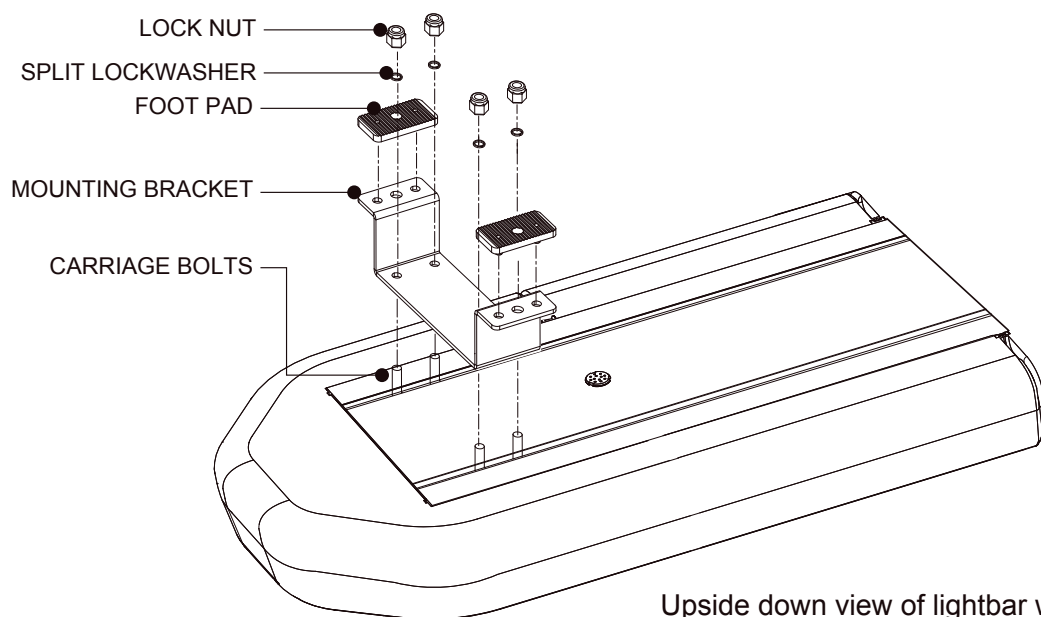

Upside down view of lightbar with mounting foot

4. Place lightbar on the mounting surface at the desired location.
5. Adjust both mounting foot assemblies in or out as necessary. If possible, try to keep mounting feet near the ends of the lightbar.
6. Using the mounting feet as a template, mark two drilling holes on each end of the mounting surface.
7. Carefully remove the lightbar and turn it upside down, and ensure that the mounting feet do not shift place.
8. Tighten the nuts that secure the mounting feet to the lightbar.

NOTE: Before drilling holes in ANY part of the vehicle, be sure that both sides of the mounting surface are clear of parts that could be damaged, such as brake lines, fuel lines, electrical wiring, or other vital parts.

9. Drill four holes at the previously marked drilling positions.
10. Place lightbar on the mounting surface and align the mounting holes with the mounting feet.
11. Secure mounting feet to mounting surface with carriage bolts.

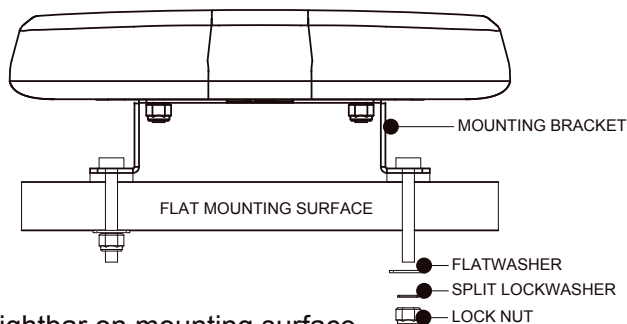

Side view of lightbar on mounting surface