

# Installation Instructions

8891215, 8891216, & 8891225

## LED Strobe Kit

Contents:

- (2) Light Heads, (1) Flasher, & Cable
- (2) Gaskets
- (4) Screws
- **OPTIONAL** (2) Flanges (8891200) with (2) gaskets

### WARNING

Light head remains hot after running. Do not touch. Do not look directly at light head as it can cause eye injuries.

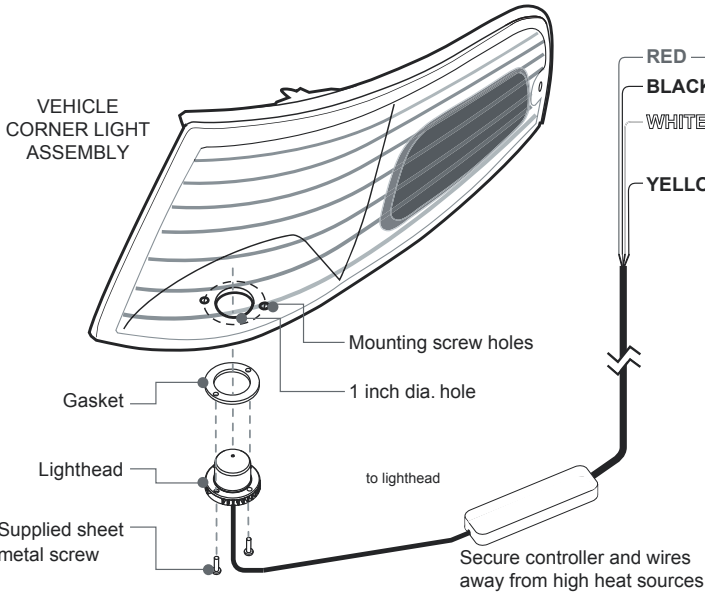

**CAUTION:** Make sure the LED lighthouse does not interfere with the operation of vehicle lights.

### LIGHT ASSEMBLY INSTALLATION

1. Remove the Corner/Head/Tail light from vehicle.
2. Select location to mount light head. Mount at least 1" from factory bulbs.
3. Drill 1" diameter hole for the light assembly. If the light housing has a double wall, drill a 1½" dia. access hole first then drill the 1" dia. hole for the light.
4. Attach gasket & insert light head into hole. Secure with supplied sheet metal screws.

**Note:** Rotate light head to achieve optimum effect as vehicle reflectors may vary.

- RED** — To +VDC (fuse @ 5A)
- BLACK** — To Chassis Ground
- WHITE** — For Simultaneous or Alternating Flash  
\*refer to "WIRING 2 KITS TOGETHER" on opposite page
- YELLOW** — For Synchronization & Flash Patterns  
Connect YELLOW wires of all Kits together for synchronization  
\*All kits must be set at the same pattern  
Use optional momentary switch (6391215) to apply +VDC to YELLOW wire:  
· once for next pattern  
· quickly three times for reset

FP#	Flash Patterns	
0	Random	10 Double (all)
1	Single (split)	11 Quad (all)
2	Double (split)	12 Quint (all)
3	Quad (split)	13 Mega (all)
4	Quint (split)	14 Ultra (all)
5	Mega (split)	15 Single-Quad (all)
6	Ultra (split)	16 Single H/L (all)
7	Single-Quad (split)	17 Steady 2 (CA)
8	Single H/L (split)	18 Steady 4 (all)
9	Single (all)	

\*SPLIT = Head1 alternate Head2 \*ALL = Head1 & 2 Simultaneous  
**NOTE:** This unit may not be factory set at FP# 0.

### ALTERNATE APPLICATION - WIRING TO EXISTING STROBE CABLES

(In this configuration, existing strobe extension cables are used to facilitate installation.)

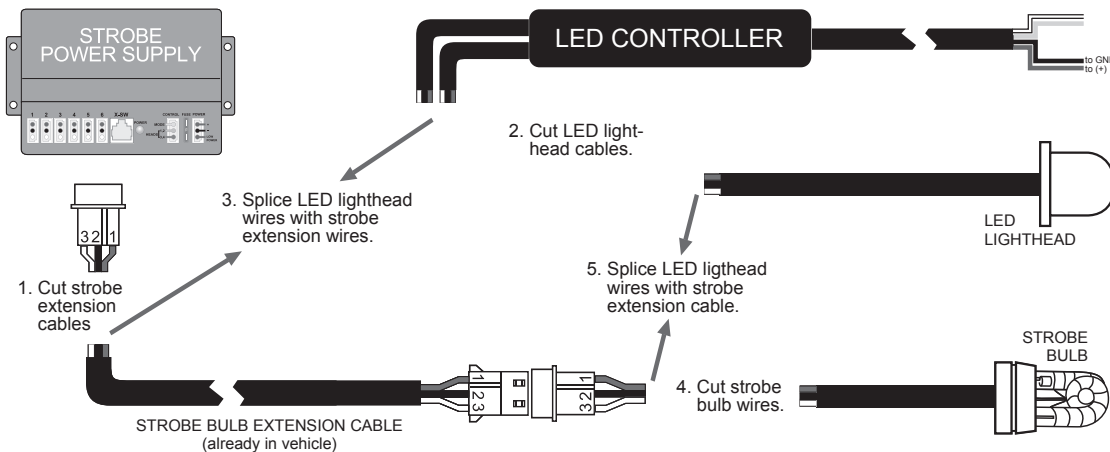

**NOTE:** Make sure that all spliced wires match colors and are well protected from moisture.

**WARNING:** Do not connect LED lighthouse directly to strobe power supply. It will cause damage and void the warranty.

## SURFACE MOUNT, FLANGE INSTALLATION

(for 2 LED kits with optional 8891200 chrome surface mounting flange)

*The flange mount option enables surface mounting of light heads.*

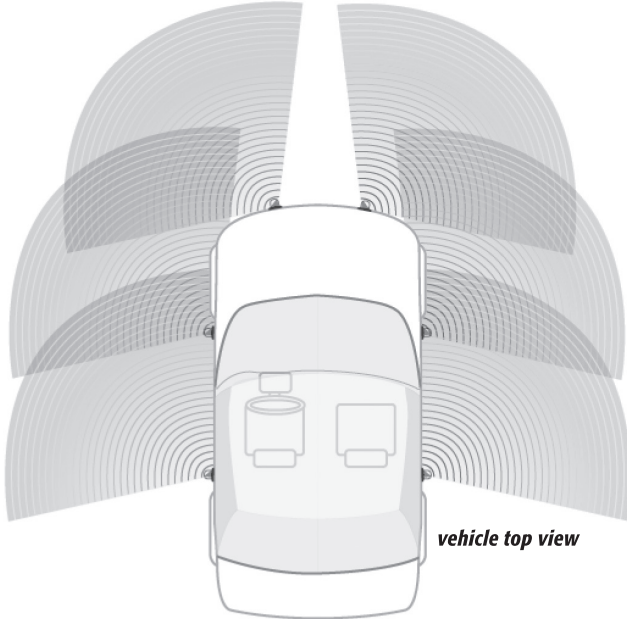

1. Use mounting flange to mark wire & screws holes to drill.
2. Drill marked holes accordingly.
3. Insert light head pigtail into wire hole.
4. Place gasket, light head, and flange in line with the mounting holes, & secure with supplied sheet metal screws.

**NOTE:** Position light head so that LED's are facing the desired direction.

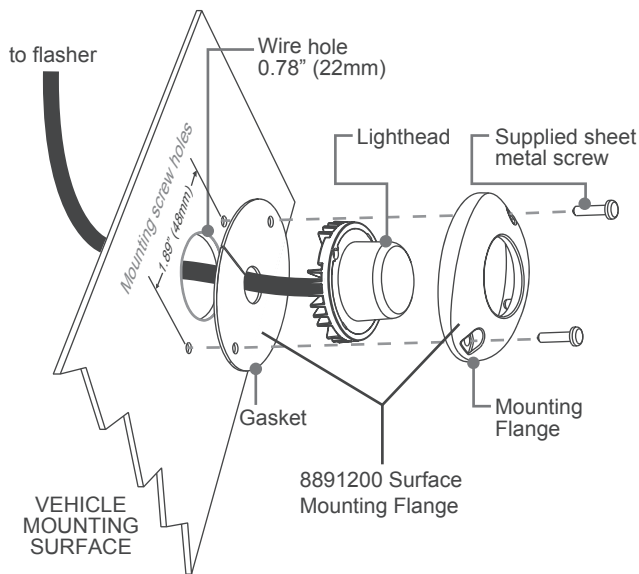

### **WARNING**

**Light head remains hot after running. Do not touch. Do not look directly at light head as it can cause eye injuries.**

## WIRING 2 KITS TOGETHER

(In this configuration, different alternating flash patterns can be achieved.)

1. If "split" flash pattern\* is selected: Heads 1&4 will alternate with Heads 2&3.
2. If "all" flash pattern\* is selected: Heads 1&2 will alternate with Heads 3&4.

\*refer to Flash Patterns chart on opposite page.

**Note:** To have Heads 1&3 alternate with 2&4, leave all **WHITE** wires disconnected & select "split" flash patterns.

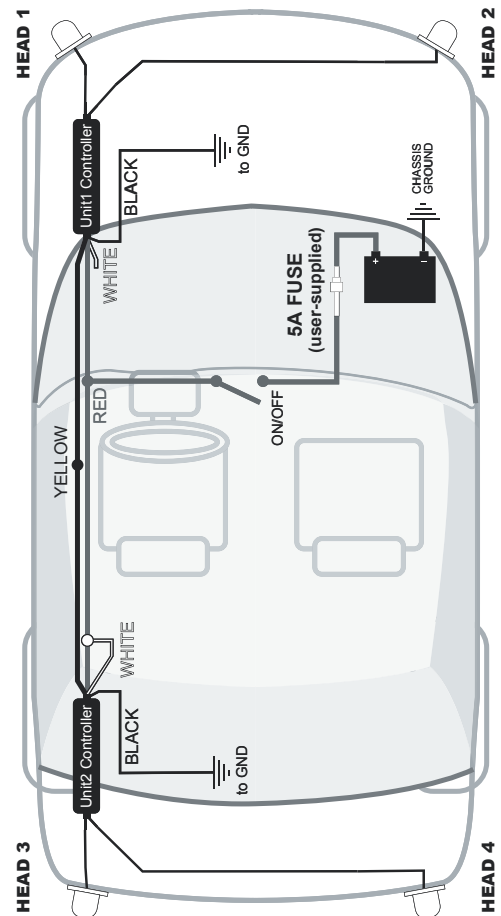

*Illustration not to scale.*

## TROUBLESHOOTING

### **STROBES NOT FLASHING:**

1. Check the RED and BLACK wires for a reversed connection
2. Check the RED and BLACK wires for a bad splice or a corroded connection.
3. Check the YELLOW wire for a short circuit to either WHITE wire or GROUND

### **STROBES NOT SYNCHRONIZED:**

1. Check the YELLOW wire for a bad splice or loose connection with Yellow wire of other units.
2. Check if the selected flash patterns for all units are the same.

### **FLASH PATTERN CHANGING:**

1. Check the YELLOW wire for an intermittent short to +VDC.