

Installation Instructions

8891090 LED Mini Light Bar

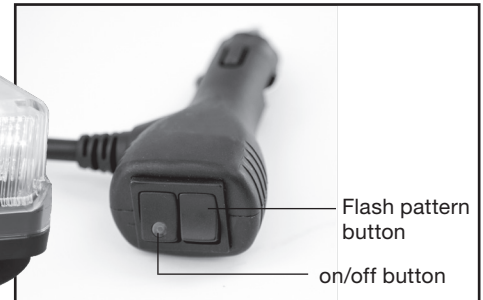

Flash Patterns

Momentarily push the Flash Pattern button:

- Once for next pattern
- Quickly 3 times for reset to FP#1

WARNING

Do not look directly into LEDs while in operation; this may cause momentary blindness and/or eye damage.

FP#	Flash Patterns
1	Random
2	Single (split)
3	Double (split)
4	Quad (split)
5	Quint (split)
6	Mega (split)
7	Ultra (split)
8	Single-Quad (split)
9	Single H/L (split)
10	Single (all) [SAE]

11	Double (all)
12	Quad (all)
13	Quint (all) [SAE]
14	Mega (all)
15	Ultra (all) [SAE]
16	Single-Quad (all)
17	Single H/L (all)
18	Steady 2 (california)
19	Steady 4 (all)

- Note:**
- 1.This unit is not factory set to FP#1
 - 2.Unit recalls last pattern used at power up
 - 3.Multi-unit synchronization capable

WARNING

Do not exceed 65 mph while using the 8891090 unless the mini lightbar is attached to the vehicle with the optional 8891091 permanent mounting kit. Exceeding 65 mph could result in failure of the suction cup style magnets, causing the mini lightbar to become detached from the vehicle. This in turn may cause vehicle damage, personal injury and/or death. A reduced driving speed is recommended during inclement weather (e.g. high winds, rain & snow storms, etc.).

Vacuum Magnet Mount (Standard)

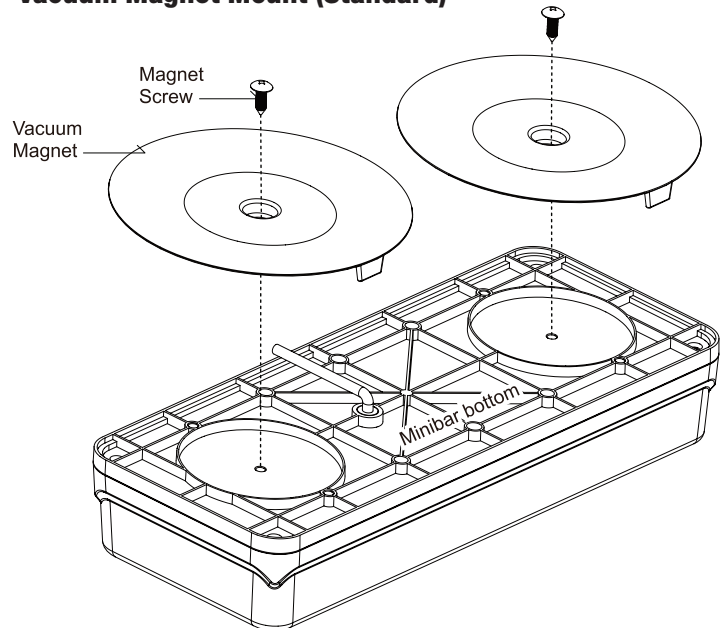

WARNING

The 8891090 mini lightbar features two suction cup style magnets for temporary mounting. It can only be mounted to vehicles with a steel body/roof. The mini lightbar must be mounted in the center of the roof, toward the middle or rear of the vehicle. Do not mount the mini lightbar close to the front windshield. The mounting area must be clean, dry, smooth, and flat. Do not mount the mini lightbar over roof ribs, common on crew cab and super crew cab trucks. Do not mount the mini lightbar to a surface that's wet or ice-covered. Carefully position the mini lightbar before placing it on the roof. Dragging the mini lightbar across the roof may leave scratches in the paint. Confirm that the mini lightbar is firmly attached to the roof before driving the vehicle on the road. Check the mini lightbar attachment daily. Replace any worn or broken parts immediately. To remove the mini lightbar, pull the tab on each suction cup style magnet to break the seal. Then carefully lift the mini lightbar off the roof. Store the mini lightbar in its box when not in use.

8891091 Optional Permanent Mount

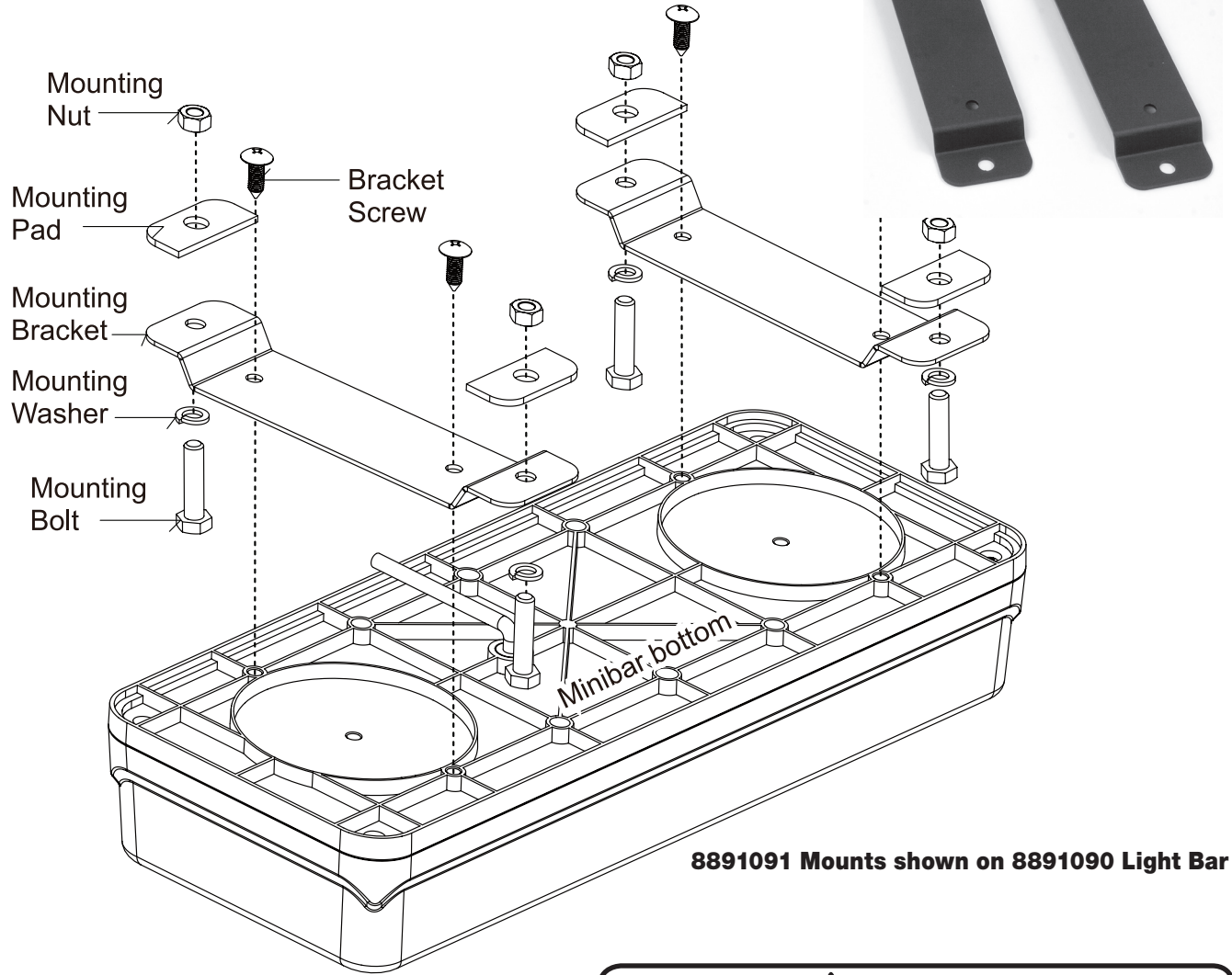

8891091 Mounts shown on 8891090 Light Bar

⚠ WARNING

Do not look directly into LEDs while in operation; this may cause momentary blindness and/or eye damage.

Wiring

RED:	To +VDC (fuse @ 5A)
BLACK:	To Chassis Ground (-)
WHITE:	For Warning Mode 2 -Apply +VDC to WHITE wire to activate Warning Mode 2
YELLOW:	Flash Patterns & Synchronization -Momentarily apply +VDC to YELLOW for Flash Pattern change -Continuously apply +VDC to YELLOW fo Low Power -Connect YELLOW wires of all light bars together for synchronization; all units must be set to same pattern
NOTE:	LED mini light bar is equipped with reverse polarity protection