

Installation Instructions

5613300 Gooseneck Flip Ball Hitch

Dodge 2500/3500 2003-2009 Long/Short Bed
Gas or Diesel
2500/3500 2010-2012 Long/Short Bed
Diesel Only (No Gas)
(excludes Mega Cab Short Bed)



To simplify the installation process, an Overhead Lifting Device is necessary to lift the center section into the appropriate location.

Use A Chain Hoist Lifting Device

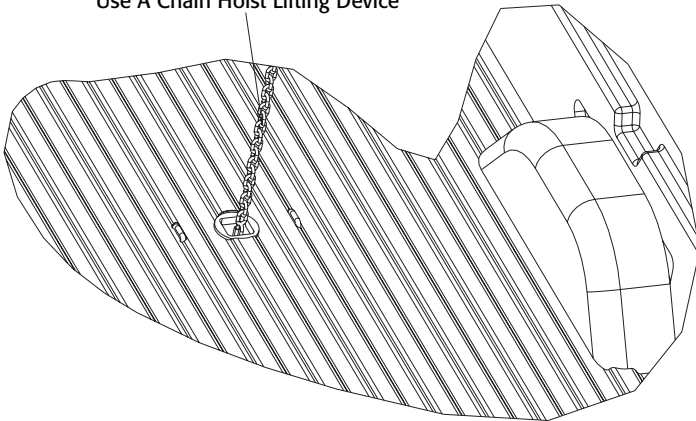

WARNING

Fuel lines, brake lines, and electrical wires are located along the frame of the truck. When positioning the gooseneck flip ball hitch, care must be taken to avoid damaging these components.

WARNING

Before installing the gooseneck flip ball hitch, check for adequate turning clearance of the front of your trailer and the truck cab

WARNING

On 2WD trucks, remove the ball from the socket when carrying heavy loads. Under load, the ball may contact the differential, causing damage.

1. Remove Spare tire off the truck temporarily for easier installation
2. If the heat shield existed and posed as an interference item, remove it carefully. Cutting and trimming may be necessary.
3. Mark from the back-edge floor of the truck 45.5" for short bed, and 47.5" for long bed. Measure the center line of the truck. Mark the spot at the intersection of the two measurements. Make a hole using a 4" Bore hole saw. If you have a drop in Bed liner, it is necessary to bore through both. (fig. 1)

Fig. 1

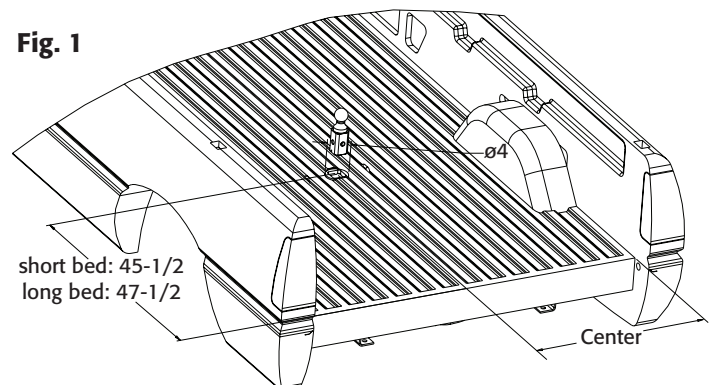

4. Your vehicle bed-flange MAY need to be notched in order to slide the cross member angle through the truck bed. You may also have to slit another triangle section on the plastic protector around the wheel tire in the same manner as the bed flange(fig. 2)

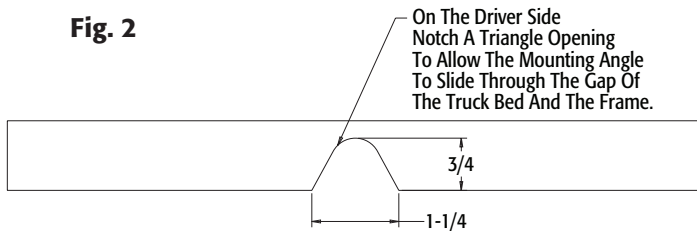

5. Slide the Rear Cross angle through the truck between the frames and the truck bed. Make sure the mounting holes are facing the front of the truck. Roll the bracket upright and slide it toward the 4" holes drilled earlier leaving about 4" space for the center section to lift into place.

6. Repeat for the Front rectangle bar with the mounting holes facing the rear. Leave about 8" total clearance between the two cross-members to accommodate for the center section (fig. 3).

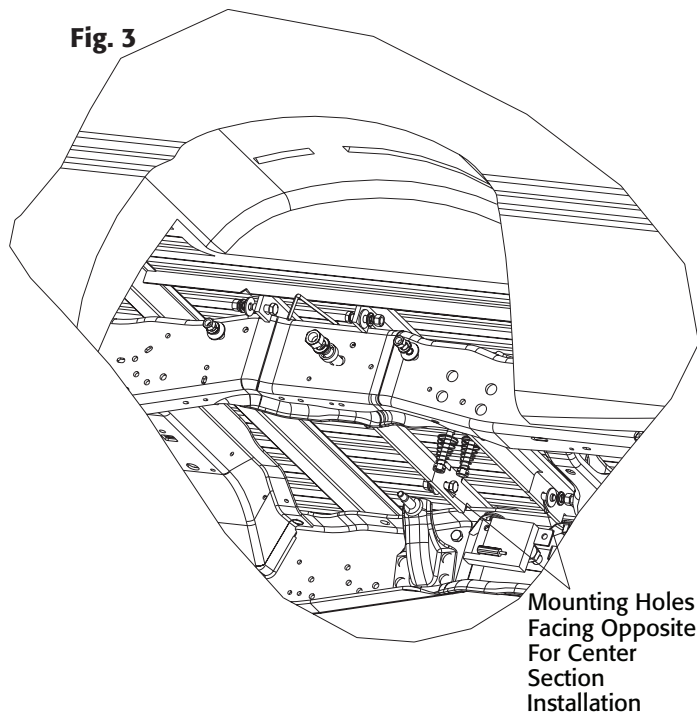

7. Install the Center Section between the two cross members just installed. The latch pin slot must be located on the driver side of the truck. Avoid obstacle such as exhaust pipe and fuel lines. Once the installation is completed, relocate/replace the vent line bracket into position. (fig. 4).

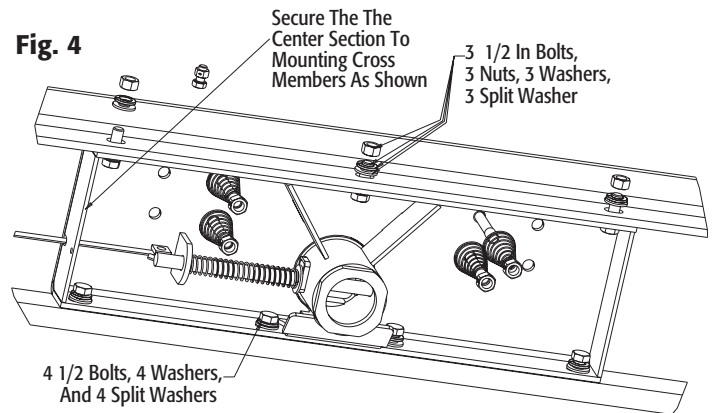

8. Install the driver side, Sideplates on the outside of the frame, aligning the hole from the bottom of the frame through the top. Secure it with the large 5/8 bolt. Some model may require you to remove the fuel line bracket and relocate to the bottom of the side plate with the 5/16 carriage bolt and nut. Also, align the u-bolt provided onto the two holes of the side-plate. Secure it with the 1/2" fasteners provided. Caution, insert the U-bolt carefully to go inside adhering to the surface of the frame – so it will not pinch the fuel line and wiring cables(fig. 5).

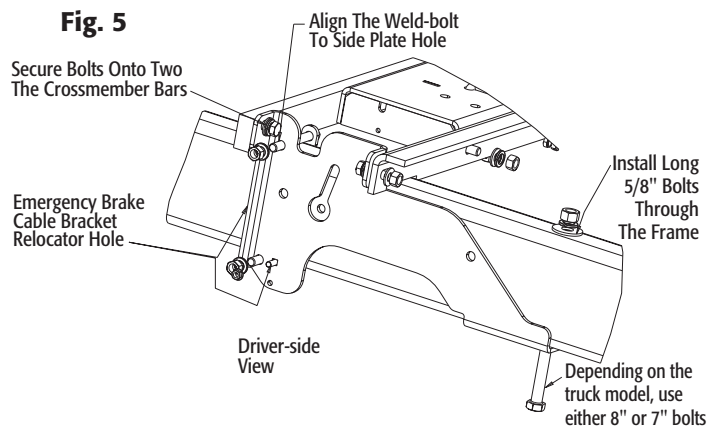

9. Repeat the sideplate installation on the passenger side. Caution, wiring must remain close to its original position as possible. Interference parts, if possible, must be relocated.

11. Tighten the center section to the crossmember at 80 ft. lb. Check to ensure the assembly is square with respect to the frame and truck bed.

12. Install the latch pin release handle from underneath the truck by inserting it through the slot. The head of the bolt must be on the front side of the truck. This is necessary for the handle to be pulled and rotated in order to disengage. You may insert the rubber protector sleeve insert at this time (fig 6).

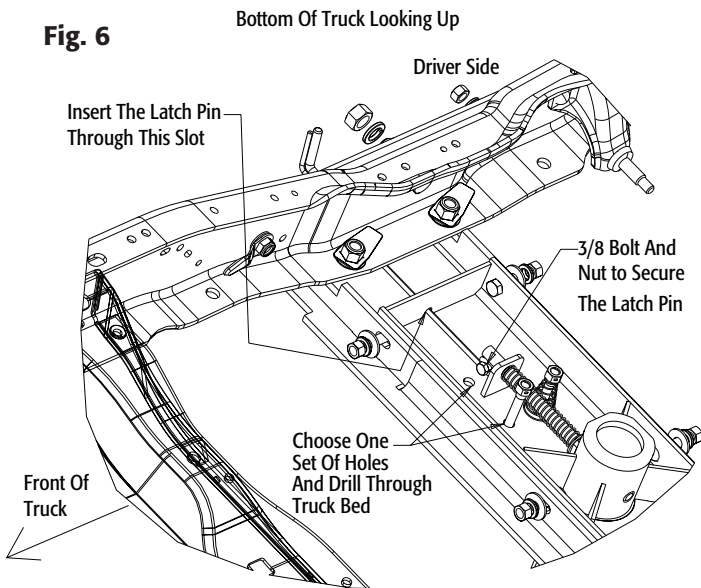

13. To install the u-bolt, it is necessary to drill four 1/2" holes through the truck bed floor. From bottom of the truck, drill upward with the 4 existing holes from the center sections. Use the set of holes that are at the bottom of the floor corrugation if possible. Install the 4 tapered springs into the holes just drilled along with the u-bolts. Secure it with 1/2" nuts provided. Make sure to turn the nuts with all the thread engaged and the springs are pulling the u-bolt downward.

14. Re-attach the Exhaust that was removed/loosened earlier.

15. Place the 2-5/16" hitch ball into the newly installed hitch. Pull and turn the latch pin to engage the ball with the hitch.

16. Make sure the pin passes through both holes of the hitch. Remove and grease the square base of the ball. Reinstall the heat shield and the spare tire to its original location.

WARRANTY

Buyers Products Co. warrants all truck/trailer hardware manufactured or distributed by it, to be free from defects in material and workmanship for a period of one year from date of shipment. Parts must be properly installed and used under normal conditions. Any product which has been altered, including modification, misuse, accident or lack of maintenance will not be considered under warranty. Normal wear is excluded. The sole responsibility of Buyers Products Co. under this warranty is limited to repairing or replacing any part or parts which are returned, prepaid, and are found to be defective by Buyers Products Co. Authorization from Buyers Products Co. must be obtained before returning any part. No charges for transportation or labor performed on Buyers' products will be allowed under this warranty.

Repair Parts - Gooseneck Hitch Assembly

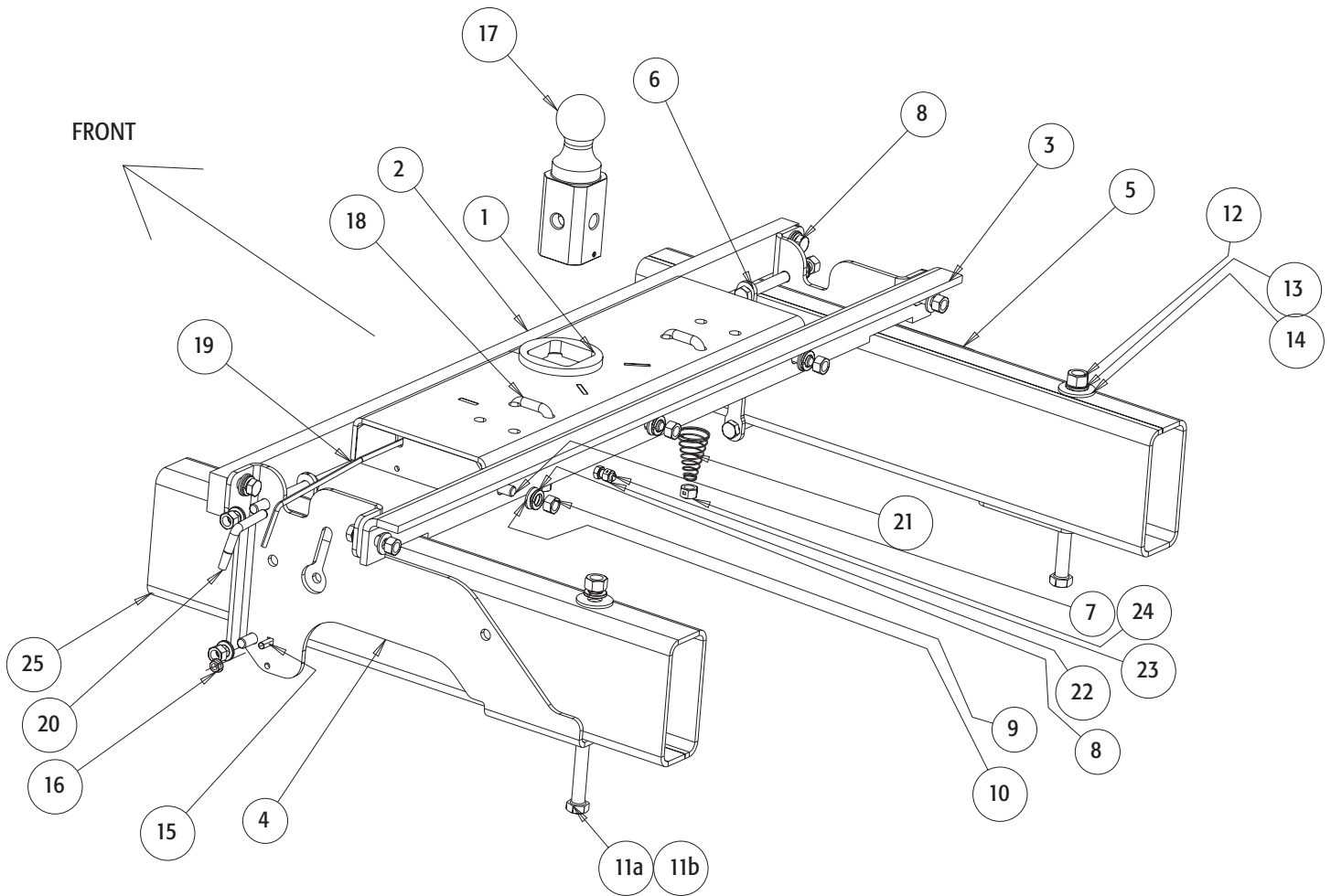

Bill of Materials

ITEM	PART NO.	QTY.	DESCRIPTION
1	3018281	1	HITCH WELDMENT, DODGE, FLIP-OVER
2	3021556	1	BAR, MOUNTING BASE
3	3021557	1	ANGLE, X-MEMBER MOUNT BASE
4	3021554	1	SIDEPLATE, DODGE DS w/ Banjo
5	3021552	1	SIDEPLATE, DODGE PS
6	3024846	2	U-BOLT
7	3006202	11	SCREW, HEX HD - 1/2-13 X 1-1/2 GR 8 ZC
8	-	15	WASHER, LOCK - 1/2 SPLIT ZN
9	3006201	9	NUT, 1/2-13 HEX GR. 8 ZP
10	-	11	WASHER, FLAT 1/2" SAE ZINC
11a	3021558	2	SCREW, 5/8-11X7
11b	FCS063011800	2	SCREW, 5/8-11X8
12	-	2	NUT, 5/8-11 ZINC

ITEM	PART NO.	QTY.	DESCRIPTION
13	-	2	WASHER, 5/8" REGULAR SPLIT LOCK, ZN
14	3000144	2	WASHER, FL - 5/8 USS ZN
15	3012144	1	BOLT, CARRIAGE, 5/16-18 X 1 SST
16	3003777	1	NUT, SERRATED FLANGE 5/16-18 ZINC
17	3018195	1	BALL, FLIP-OVER, WITH PIN
18	3018214	2	U-BOLT, SQUARE ZINC, SPECIAL
19	3018211	1	ROD, PULL, ZY
20	3018212	1	SLEEVE, VINYL, 1/4 X 4, BLACK
21	3018215	4	SPRING, COMPRESSION, TAPER COIL
22	3018216	1	NUT, HEX, 3/8-16, CENTER LOCK, ZP
23	-	1	SCREW, 3/8-16 X 3/4 CAP
24	3002218	4	NUT, CENTER LOCK HEX 1/2-13 ZN
25	-		TRUCK FRAME