

# Installation Instructions

## 5613100 Gooseneck Flip Ball Hitch

GM - 2001-2010 ¾ & 1 Ton,  
Short & Long Bed - with 1 cross  
member over axle on 1 Ton truck

To simplify the installation process, an Overhead Lifting Device is necessary to lift the center section into the appropriate location.

Use A Chain Hoist Lifting Device

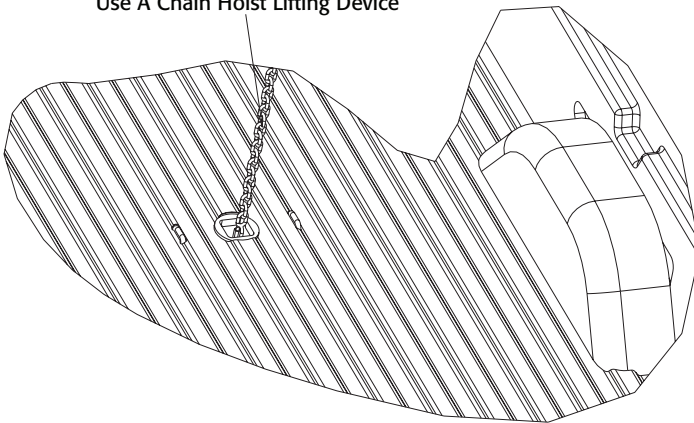
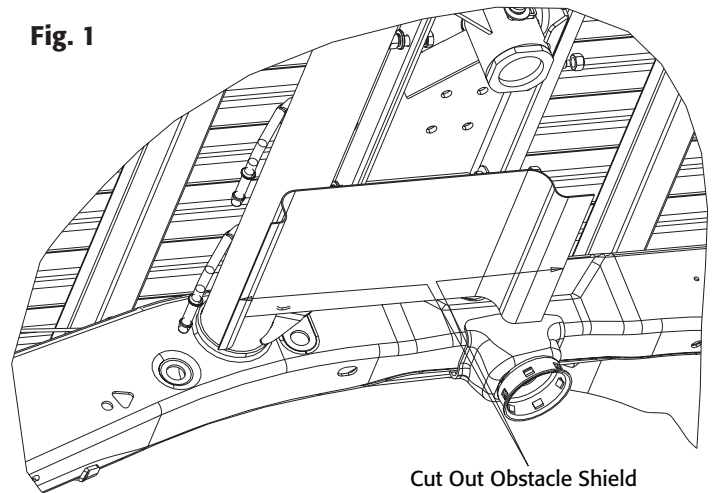

Fig. 1



### ⚠ WARNING

Fuel lines, brake lines, and electrical wires are located along the frame of the truck. When positioning the gooseneck flip ball hitch, care must be taken to avoid damaging these components.

### ⚠ WARNING

Before installing the gooseneck flip ball hitch, check for adequate turning clearance of the front of your trailer and the truck cab

### ⚠ WARNING

On 2WD trucks, remove the ball from the socket when carrying heavy loads. Under load, the ball may contact the differential, causing damage.

1. Remove the spare tire and spare tire heat shield (if present) and set aside.
2. Remove the heat shield located above the rear axle under the truck bed. Cut out the portion of the heat shield above the axle where your cross angle and crossbar will be installed. (fig. 1)

3. Exhaust bracket needs to be lowered for this vehicle truck. Detach the tail pipe bracket just behind the rear tire on the passenger side.

4. Locate the center spot for the 4 inch center section installation. (fig. 2)

- A. Measure from the back of the truck bed 44.25" for short bed (49.5" for long bed) and center of the truck, mark the spot.
- B. After confirming the location, make a 4" hole. A 4" hole saw is recommended
- C. Deburr or grind the hole edges.

Fig. 2

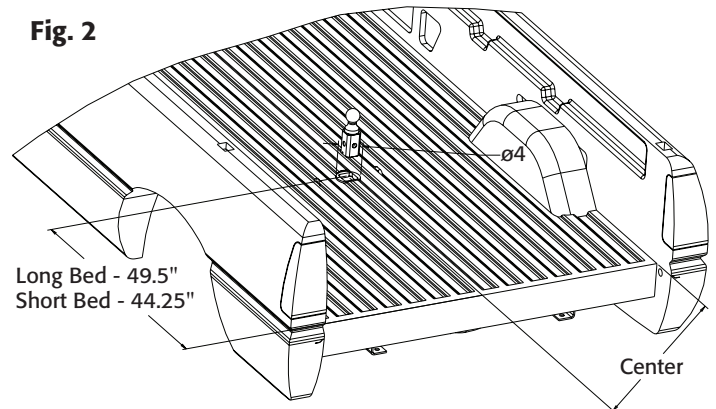

5. Your vehicle bed-flange will need to be notched in order to slide the cross member angle through the truck bed (fig. 3)

Fig. 3

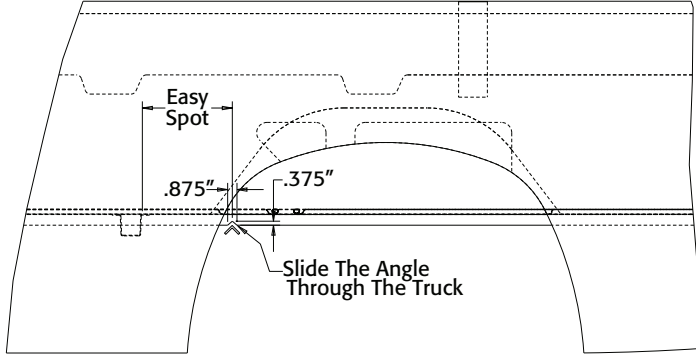

6. Slide the Rear Cross angle through the truck between the frames and the truck bed. Make sure the mounting holes are facing the front of the truck. Roll the bracket upright and slide it toward the 4" holes drilled earlier leaving about 4" space for the center section to lift into place.

7. Repeat for the Front Cross angle of the truck, with the mounting holes facing the rear of the truck. Leave about 8" total clearance between the two cross angles to accommodate for the center section (fig. 4).

Fig. 4

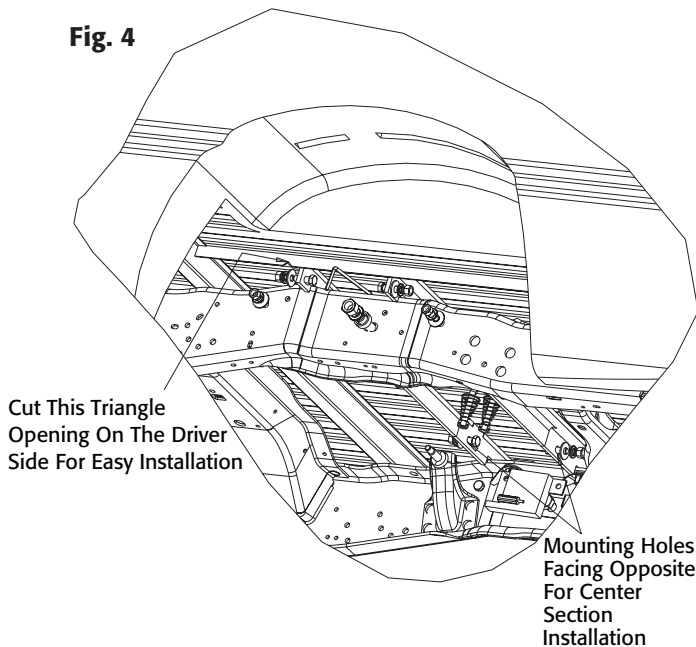

8. Install the Center Section between the two cross angle just installed. Install the Center section into the 4" bore hole. For 2004+ vehicles, a fuel valve will have to be temporarily removed during installation. Re-attach afterward. (fig. 5).

Fig. 5

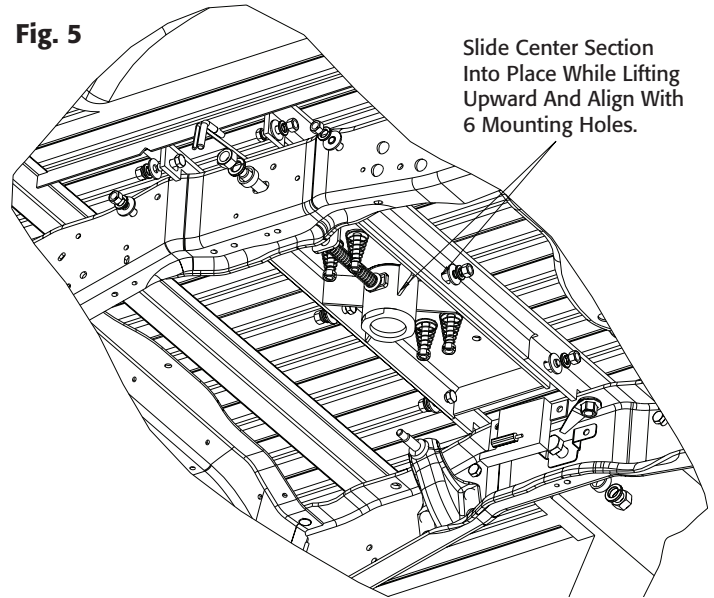

9. Install the side plates on the outside of the frame using the 3/4" bolts, washers, and spacers provided. Install the vertical side plate with U-Bracket as shown. (fig. 6).

Fig. 6

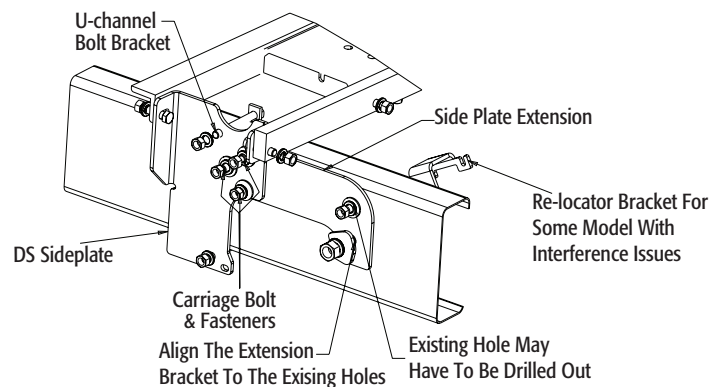

10. Repeat the sideplate installation on the passenger side. If the passenger side is interfered with a sensor device, it must be relocated using the supplied bracket. Caution, do not remove the heat shielding from wire harness. Wiring must remain close to its original position as possible.

**11.** Tighten the center section to the crossmember at 80 ft. lb. Check to ensure the assembly is square with respect to the frame and truck bed.

**12.** Install the latch pin release handle from underneath the truck by inserting it through the slot. The head of the bolt must be on the front side of the truck. This is necessary for the handle to be pulled and rotated in order to disengage. You may insert the rubber protector sleeve insert at this time (fig 7).

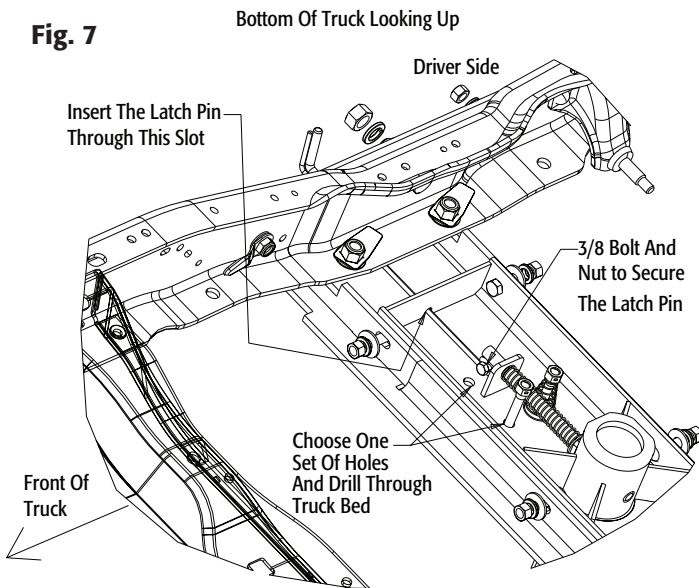

**13.** To install the u-bolt, it is necessary to drill four 1/2" holes through the truck bed floor. From bottom of the truck, drill upward with the 4 existing holes from the center sections. Use the set of holes that are at the bottom of the floor corrugation if possible. Install the 4 tapered springs into the holes just drilled along with the u-bolts. Secure it with 1/2" nuts provided. Make sure to turn the nuts with all the thread engaged and the springs are pulling the u-bolt downward.

**14.** Re-attach the Exhaust that was removed earlier. Additional extension may be needed to remount the exhaust. (fig. 8).

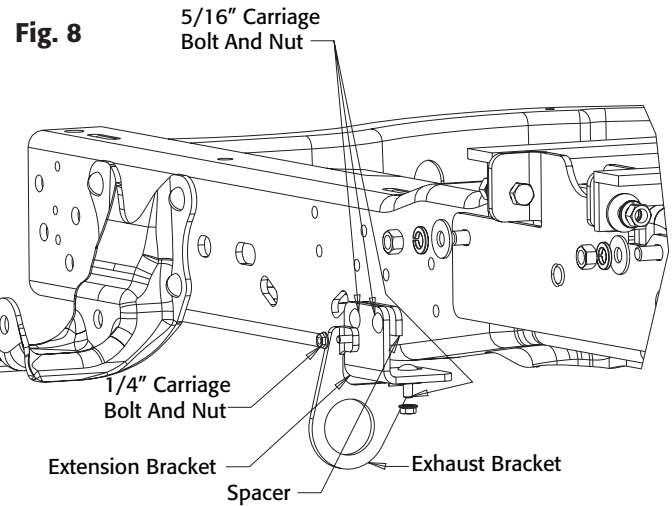

**15.** Place the 2-5/16" hitch ball into the newly installed hitch. Pull and turn the latch pin to engage the ball with the hitch.

**16.** Make sure the pin passes through both holes of the hitch. Remove and grease the square base of the ball. Reinstall the heat shield and the spare tire to its original location.

#### WARRANTY

Buyers Products Co. warrants all truck/trailer hardware manufactured or distributed by it, to be free from defects in material and workmanship for a period of one year from date of shipment. Parts must be properly installed and used under normal conditions. Any product which has been altered, including modification, misuse, accident or lack of maintenance will not be considered under warranty. Normal wear is excluded. The sole responsibility of Buyers Products Co. under this warranty is limited to repairing or replacing any part or parts which are returned, prepaid, and are found to be defective by Buyers Products Co. Authorization from Buyers Products Co. must be obtained before returning any part. No charges for transportation or labor performed on Buyers' products will be allowed under this warranty.

## Repair Parts - Gooseneck Hitch Assembly

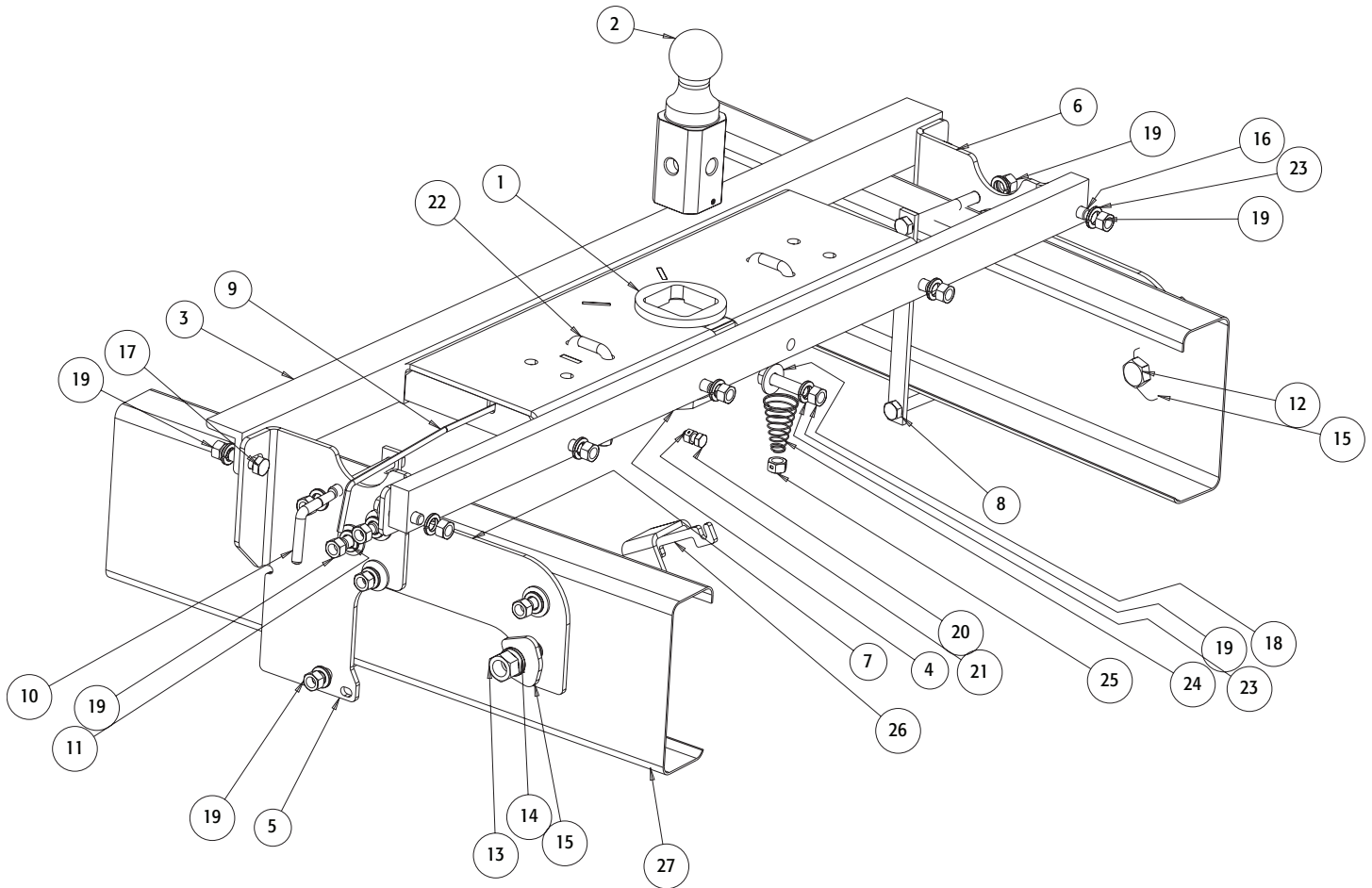

### Bill of Materials

ITEM	PART NO.	QTY.	DESCRIPTION
1	3018248	1	Hitch, CTR section, Weldment, GM
2	3018195	1	Ball, Flip-Over, with Pin
3	3021534	1	Angle, Rear Brace
4	3021533	1	Bar, Mounting Base
5	3021542	1	Sideplate, DS, 01-1-10 GM
6	3021543	1	Sideplate, PS, 01-10 GM w/ SQ Hole
7	3021544	2	Plate, Side Extension
8	3024874	2	U-Bolt, Weldment Special
9	3018211	1	Rod, Pull, ZY
10	3018212	1	Sleeve, Vinyl, 1/4 x 4, Black
11	-	6	Bolt, Carriage 1/2-13 x 1.25 Gr. 5, ZN
12	-	2	Screw, HHC, 3/4-10 x 2 Gr. 5, ZN
13	-	2	Nut, Hex 3/4-10 Gr. 5, ZN
14	-	2	Washer, Lock 3/4, ZN

ITEM	PART NO.	QTY.	DESCRIPTION
15	3021749	4	Bracket, Brake Re-locator
16	-	6	Screw, Hex Cap 1/2-13 x 2" Gr. 5, ZN
17	-	7	Screw, Hex Cap 1/2-13 x 1-1/2" Gr. 8, ZN
18	-	15	Washer, Flat, .50 x 1.38 x .14, ZN
19	-	23	Nut, 1/2-13 Hex, Gr. 8, ZN
20	-	1	Screw, 3/8-16 x 3/4 CAP
21	-	1	Nut, Hex, 3/8-16, Center Lock, ZN
22	3018214	2	U-Bolt, Square, ZN Special
23	-	23	Washer, Lock -1/2 Split, ZN
24	3018215	4	Spring, Compression, Taper Coil
25	3002218	4	Nut, Center Lock Hex 1/2-13 ZN
26	3021545	1	Bracket, Brake Re-Locator
27	-	-	Truck Frame