

Installation Instructions

5544xxx and 5545xxx Automatic Tarp Systems

Section 1 – Installing the Head Assembly

1. Determine the Mounting Location for the Head Assy.

A. Mount the Head Assembly on top of the cab shield and as far forward as possible to minimize interference when side loading dump.

B. When choosing the location, it will be helpful to visualize a line from the approximate pivot location to the Axle to see if the arms are clear.

C. If vertical exhaust stacks are in the way of the ideal location you can choose to shorten or realign the stacks or mount the Head Assembly behind them.

2. Install the DS (left) & PS (right) Mounting Brackets

A. Use the included (4) 1/2"-20 x 1" HHCS (Hex Head Cap Screws) and Locknuts.

3. Mount the Gear Motor

A. Using (5) 5/16"-18 x 5/8" Button Head Screws (in motor box) to attach the Gear Motor to the DS Mounting Bracket

4. Fit the Aluminum Roller Axle

A. Axle will need to be long enough to mount on the Gear Motor and reach up to 1" from the PS Mounting Plate

B. Cut the Axle to this length

5. Mount the Gear Motor

A. Drill a clearance hole (5/16" Bolt) in the Roller Axle 1" from the end.

B. Attach the Gear Motor to the Axle using a 5/16"-18 x 2-3/4" HHCS (Hex Head Cap Screws) and Nylon Locking Nut.

6. Mount Bearing Side the Stub Shaft

A. Drill a clearance hole (5/16" Bolt) from the end of the Roller Axle.

B. Mount the Stub Shaft to the Axle using a 5/16"-18 x 2-3/4" HHCS (Hex Head Cap Screws) and Nylon Locking Nut.

NOTE: The long end of the Stub Shaft should be outside the end of the Roller Axle

7. Mount the Bearing

A. Insert the Stub Shaft to the Bearing and attach to the PS Mounting Bracket using (2) 3/8" x 1" HHCS (Hex Head Cap Screws) and Nylon Insert Locking nuts

8. Install the Wind Deflector

A. Cut to fit in between the DS and PS Mounting Brackets

B. Attach it using the (8) 1/4"-20 x 1-1/2" Thread Cutting Bolts



Section 2 – Wiring the System

1. Refer to Fig. 2 for the Wiring Diagram

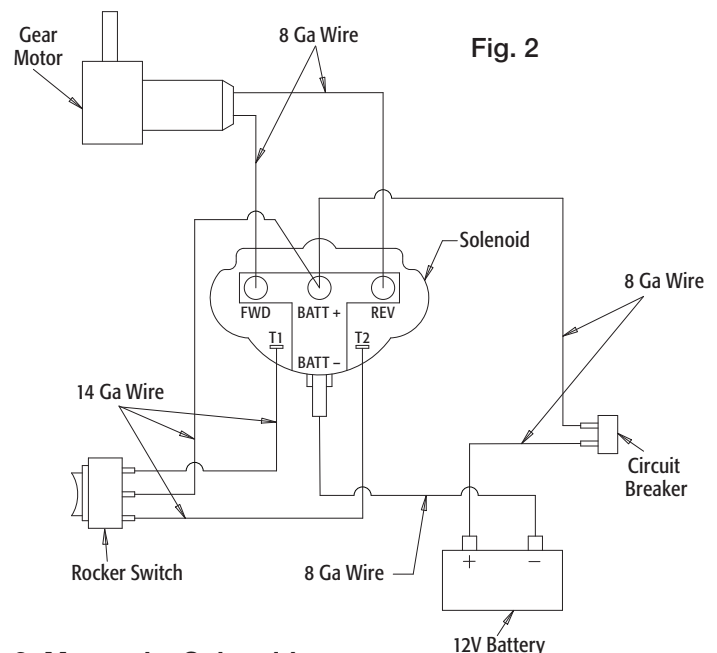

2. Mount the Solenoid

A. Find a location to mount the Solenoid. It should be in a location that will minimize the amount of necessary wire and must be protected from the elements (rain water and road spray)

B. Use (2) 1/4"-20 x 1-1/2" HHCS and Flange nuts to mount the Solenoid.

NOTE: Make sure that the bolt heads are on the backside of the Solenoid as the Cover will be added later.

3. Wiring the Motor to Solenoid

A. Using the 8Ga Wire, (2)5/16"-24 Kepnuts, (2)1/4"-8Ga Ring Terminals and (2)3/8"-8Ga Ring Terminals, Connect the Gear Motor to the Solenoid

4. Wiring the Solenoid and Circuit Breaker

A. Using the 8Ga Wire, (1)5/16"-24 Kepnut, and (2)3/8"-8Ga Ring Terminals, loosely connect the Negative Post of the Battery to the Solenoid post labeled "BATT -".

WARNING

Failure to follow the wiring diagram could lead to electrical failure of the motor and/or voiding the warranty.

NOTE: After verifying fit, REMOVE connection from the Battery until the rest of the system is wired.

B. Using the 8Ga Wire, (1)#10-8Ga Ring Terminal, (1)3/8"-8Ga Ring Terminal, and (1)5/16"-24 Kepnut, connect the Circuit Breaker to the "BATT +" post on the Solenoid. Do NOT tighten at this time.

C. Using the 8Ga Wire, (1)#10-8Ga Ring Terminal and (1)3/8"-8Ga Ring Terminal, connect the Circuit Breaker to the Positive Post on the Battery

5. Installing the Motor Reversing Switch

A. Using (2) 1/4"-20 x 1-1/2" HHCS and flange nuts mount the Switch Bracket and Switch to a desired location.

B. Using the included 14Ga wire and (4) Female, Push-On Terminals, connect the outside terminals of the Switch to the terminals T1 and T2 of the Solenoid

C. Use the 14Ga wire, (1) Female, Push-On Terminal and (1) 3/8"-14Ga Ring Terminal to connect the center terminal of the Switch to the "BATT +" post on the Solenoid. (Loosen the Kepnut already on the post, attach Ring Terminal and fully tighten Kepnut)

6. Connecting the Battery and Testing

A. Reconnect the Negative Wire to the battery post

B. Test operation of the Switch. If the direction is incorrect, either change the wires on the back of the Gear Motor OR switch the T1 and T2 connections to reverse the rotation.

C. Apply Dielectric grease to all electrical connections

D. Mount the Protective Cover on Solenoid by loosening the nuts, sliding it on and then tighten to secure in place

Section 3 – Fitting & Installing Pivots, Arms, & Tarp

NOTE: Prior to final assembly it is recommended to apply anti-seize to all metal to metal connections.

1. Determine the Pivot Point (Fig. 3a)

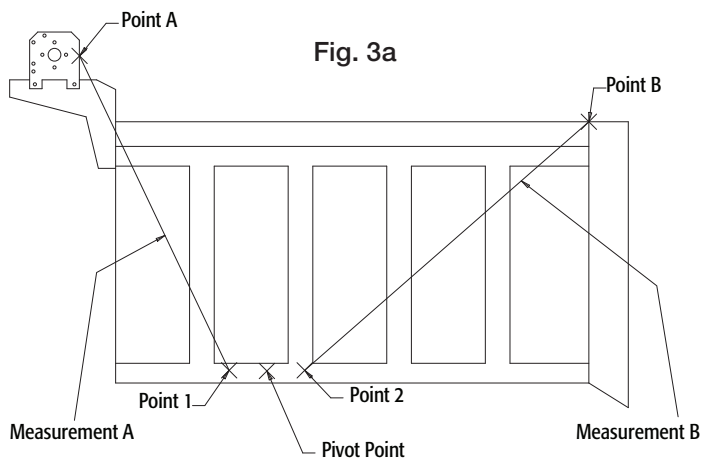

A. Measure from Point A to the point on the side rail that is approximately where the pivot point will be. Mark this point(Point 1) and record it as Measurement A.

B. From Point B(where you want the tarp to end), use Measurement A to mark this point(Point 2) on the rail.

C. Mark your pivot point at 1/2 the distance between Point 1 & Point 2.

D. To mark the pivot point on the other side, measure from the back of the box to the first pivot point and transfer this measurement to the other side.

2. Mounting Pivot Assemblies

A. On the Driver Side and Passenger Side Rails, measure and mark (2) locations 4-1/4" from the previously identified Center Pivot Points. Drilling 3/4" holes at these locations will give you holes 8-1/2" apart for mounting the Pivot Assemblies.

B. Using the included 5/8"-11 x 1-1/2" Bolts, Washers, and Locknuts bolt the Pivot Assemblies to the box.

NOTE: Pivots are directional and must be mounted to their correct sides. Grooves point toward ground. (See Fig. 3b).

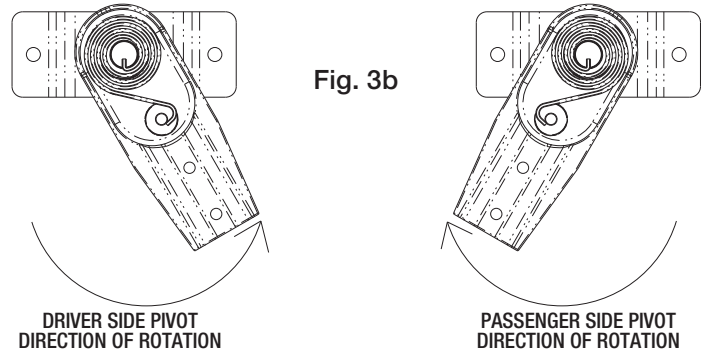

3. Verify Fit of System (WITHOUT SPRINGS)

A. Install Pivot Covers & Lower Arms with NO SPRINGS

B. Insert Corner Connectors into Upper Arms. Fasten by drilling a hole through the Upper Arm and Corner Connector and bolting together using the supplied 5/16"-18 x 1-3/4" HHCS and Nylon Locking Nuts.

C. Install one Upper Arm into a Lower Arm

D. Adjust the Upper Arm length until the Corner Connector rests on the Desired landing point at the back of the box. If the Upper Arm is too long, cut it to fit. **NOTE: Be Sure To Maintain At Least 24" Inside The Lower Arm**

E. Cut the other Upper Arm to the same length and insert it on the other side so both Upper Arms are inserted the same amount

F. Measure the distance between the Corner Connectors and cut the Rear Arm to this length. Fit by drilling a hole through the Rear Arm and Corner Connectors. **NOTE: Do Not Bolt Together At This Time.**

G. Swing the Bow Assembly toward the Head Assembly. It should rest in the center of the Head Assembly. Adjust as needed.

H. Swing the Bow Assembly back toward the rear of the truck and verify that the rear resting point is in a desired location and does not interfere with the tailgate operation. **NOTE: If position is not as desired the Pivot Point may need moved and the verification of fit repeated.**

I. Once verified, mark the position of the Upper Arms so they can easily be returned to the same place without re-measuring.

J. Remove the Rear and Upper Arms from the Lower Arms

K. Loosely install Arm Guides on the Upper Arms

4. Installing the Tarp

- A.** Line up the grommets on the front edge of the tarp with the threaded slot of the Axle
- B.** Center the Tarp and then attach it to the Axle using the included 5/16"-18 x 5/8" Button head Bolts (from hardware bag) and 5/16" flat washers
- C.** Slide the Rear Arm through the pocket in the Tarp
- D.** Slide (2) Arm Guides on each end of the Rear Arm
- E.** Center the Tarp on the Rear Arm, Slide the inner set of Arm Guides against Tarp and tighten them in position. Be careful not to over tighten.

5. Mounting the Lower Pivot Assemblies

- A.** Remove the loosely Assembled Lower Arms and Pivot Covers then fully reinstall all the Pivot Assembly components referring to Fig. 3c. **NOTE: Double check the Pivot Mount groove is facing down and that the Springs are installed as per Fig 3b. Be sure to install the Lower Arms so that the set screw holes are facing the same direction**

Fig. 3c

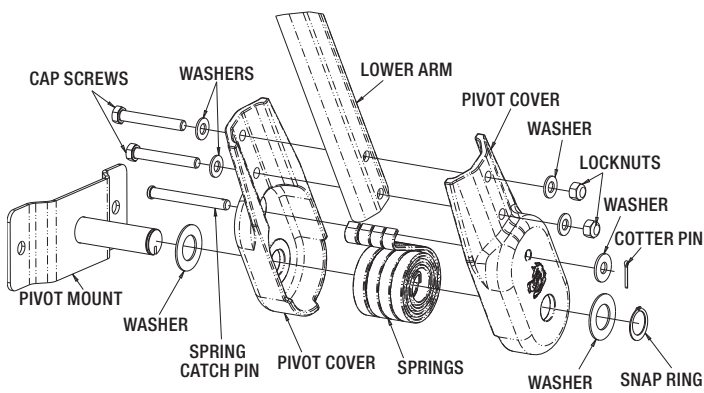

- B.** With the help of at least one other person, rotate the Lower Arms, preloading the springs, so that the Upper Arms with Corner Connectors may be inserted
- C.** Attach the Rear Arm (with Tarp pre-mounted) to the Corner Connectors by bolting together using the supplied 5/16"-18 x 1-3/4" HHCS and Nylon Locking Nuts
- D.** Position the Upper Arms to the previously marked locations and use the included screws to tighten in place. **NOTE: Be careful not to over tighten**
- E.** Position and tighten the remaining Arm Guides
- F.** Double check all fasteners are fully tightened, all wire connections are secured and test the system

Section 5 – General Information & Troubleshooting

1. Operation of the Tarp System

- A.** The Tarp System should only be opened and/or closed when the truck is stationary. Winding or unwinding the Tarp System while the truck is moving may cause damage if the wind catches the tarp or if the Bow Assembly hits trees, power lines, overpasses, bridges, etc.

- B.** The tarp should always be wound OVER the top of the Axle to prevent foreign materials from being rolled into the tarp and possibly jamming the tarp or causing damage
- C.** Before operating the Tarp System, be sure that there are no obstructions in the Head Assembly such as debris or ice as this may cause damage to the tarp or cause the breaker to trip.
- D.** Inspect the Tarp System regularly (daily inspection is recommended) for any issues. Replace any damaged component before operating the Tarp System

2. Gear Motor

- A.** The Gear Motor is a single unit & is only serviced as such.
- B.** The Gear Motor should not be modified in any way. Any modifications will void the warranty
- C.** If you believe your Gear Motor has failed, follow these steps before removing it
 - i.** Disconnect the motor wires from the terminals
 - ii.** Test the motor using a fully charged 12V battery & 8Ga or larger jumper cables between the battery & motor terminals (Do NOT leave connected and do NOT use a battery charger)
 - iii.** If the gear motor runs, switch the connections at the motor terminals & perform the same test in the opposite direction
 - iv.** If the Gear Motor does not run in one or both directions then it needs replaced
 - v.** If the Gear Motor runs in both directions then the problem is not the motor and the rest of the System must be checked
 - 1. Look for bad connections or broken wires,
 - 2. Incorrect wire gauge
 - 3. Tarp no longer fastened to the Axle
 - 4. Tripped Circuit Breaker
 - 5. Damaged or defective Circuit Breaker, Solenoid, or Switch

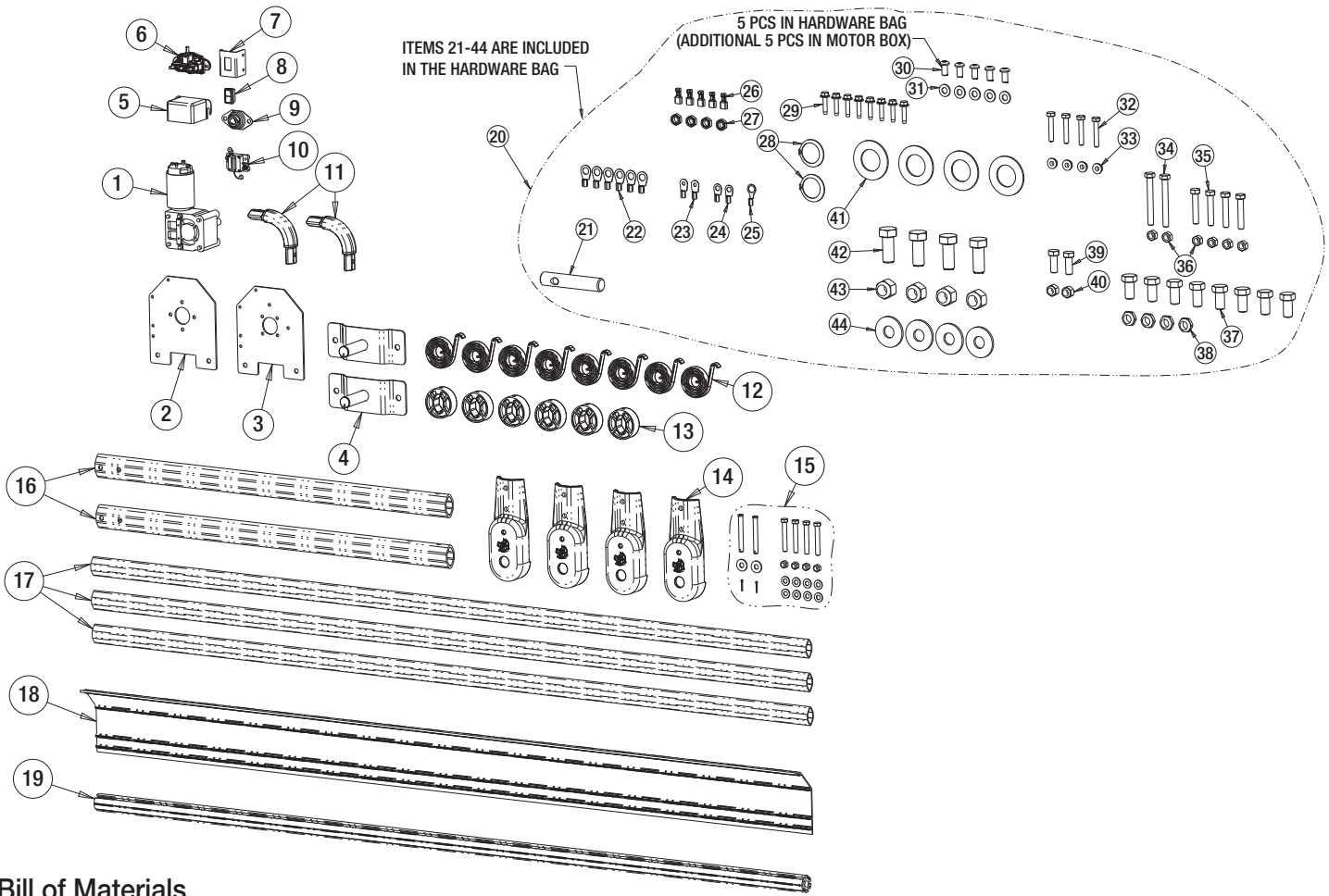

Bill of Materials

ITEM	PART NO.	QTY	DESCRIPTION
1	5541095	1	Gear Motor,12VDC,600W,90:1,1YR
	5543095	1	Gear Motor,12VDC,600W,90:1,3YR
	5543965	1	Gear Motor,12VDC,900W,60:1,3YR
	5543895	1	Gear Motor,12VDC,900W,90:1,3YR
2	3011874	1	PS Mounting Bracket
3	3011873	1	DS Mounting Bracket
4	3012781	2	Spring Pivot Assembly
5	3014186	1	Solenoid Cover
6	1306600	1	Solenoid
7	3014188	1	Switch Bracket
8	3014187	1	Rocker Switch
9	3012784	1	Bearing
10	CB60	1	Circuit Breaker, 60Amp, Auto Reset
11	3011866	2	Corner Connector
12	3011876	8/10	Spring
13	3012786	6	Arm Guides
14	3028340	4	Pivot Cover
15	3031039	1	Pivot Arm Hardware Kit
16	3011867	2	Lower Arm - 4 Spring Kit
	3012782	2	Lower Arm - 5 Spring Kit
17	3011869	3	Upper and Rear Arms
18	3011871	1	Wind Deflector
19	3011870	1	Roller Axle
20	3030922	1	Hardware Bag - Tarp Kits
21	3012785	1	Stub Shaft
22	3020809	6	3/8" - 8 Ga, Ring Terminal
23	3020810	2	#10 - 8 Ga, Ring Terminal

ITEM	PART NO.	QTY	DESCRIPTION
24	3020811	2	1/4" - 8 Ga, Ring Terminal
25	3014212	1	3/8" - 16-14 Ga, Ring Terminal
26	3008037	5	16-14 Ga, Female Push-On Terminal
27	3014222	4	Kep Nut, 5/16"-24
28	3001432	2	Snap Ring
29	3014109	8	Thread Cutting Screw, 1/4"-20 x 1"
30	3014225	10	Button Head Screw, 5/16"-18 x 5/8"
31	FWF031075006	5	Flat Washer, 5/16"
32	3014224	4	Cap Screw, 1/4"-20 x 1-1/2"
33	3014223	4	Nut,Serrated Flange,1/4"-20
34	FCS031018275	2	Cap Screw, 5/16"-18 x 2-3/4"
35	FCS031018175	4	Cap Screw, 5/16"-18 x 1-3/4"
36	FNE031018034	6	Nut,Nylon Locking, 5/16"-18
37	FCS050020100	8	Cap Screw,1/2"-20 x 1"
38	FNE050020031	4	Nut,Jam,Nylon Locking,1/2"-20
39	FCS038016100	2	Cap Screw, 3/8"-16 x 1"
40	FNE038016044	2	Nut,Nylon Locking, 3/8"-16
41	13030351	4	Flat Washer,1-1/4" ID
42	3009878	4	Cap Screw, 5/8"-11 x 1-1/2"
43	FNE063011069	4	Nut,Nylon Locking, 5/8"-11
44	3000144	4	Flat Washer, 5/8"

NOT SHOWN

-	3012783	1	60FT - 8 Ga, Dual Conductor Wire
-	3014217	1	20FT - 14 Ga, 3-Conductor Wire
OPTIONAL KITS - SOLD SEPARATELY			
-	5540710	1	Rotary Swich Kit
-	3014230	1	30 Degree Elbow (2 required per system)