



# LiftDogg™ TRUCKMOUNT

## MOUNT KIT 5051200

F-150/F-250/F-350 –  
1973-1996

F-250HD/F-350HD –  
1997

## INSTALLATION MANUAL

1. Secure the mounting extension (3) to the Mounting holes of the liftgate using eight 3/8" bolts, eight washers, and eight locknuts. (fig.1)

**Fig. 1**

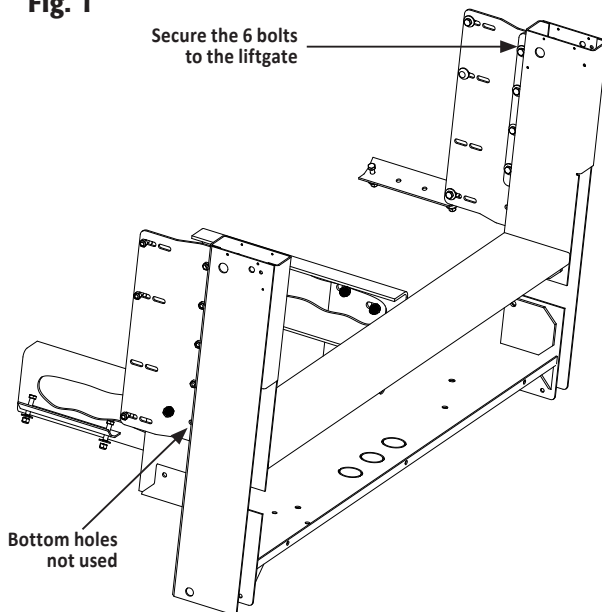

2. On the truck, remove the tailgate and tailgate hardware. On the 2004-present, only the tailgate needs to be removed. (fig. 2)

**Fig. 2**

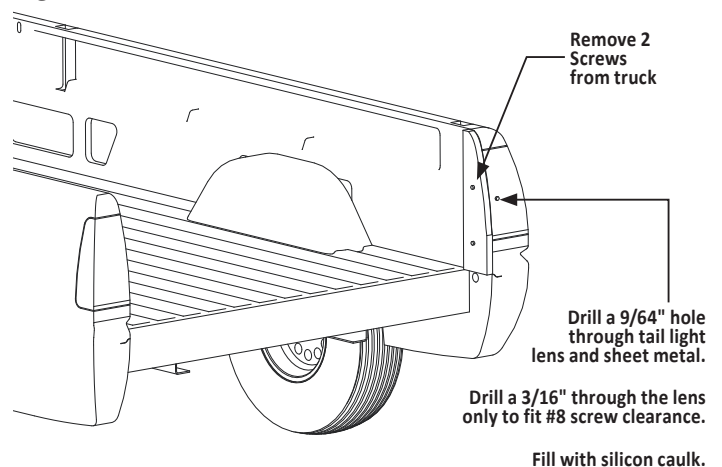

3. Remove the rear bumper. Be careful not to drop the bumper when removing the fasteners. On the 2004 to present F150 model, you will need to remove the hitch.
4. On the 2008+ models, the tail light can only be accessed after doing the following modification.
  - a. Remove the two screws from the tail light lens. The screws will not be re-used.
  - b. Drill a 9/64" hole through the tail light lens and the truck's sheet metal.
  - c. Follow up with a 3/16" hole for the #8 screws to hold the light in place. Do not over tighten.
5. Place the filler sheet metal on the liftgate before trying to mount on the truck. The filler sheet metal will act as a gap bridge between the truck-bed and the liftgate.

6. Weld the supplied filler sheet metal to the top corner of the liftgate upper frame.
7. Align the mounting brackets into the truck bed corner posts. Do not drill yet.
8. Place the Liftgate into the bed opening so it will align with the spare tire tube. Make sure it is centered in the opening of the truck, flush with the bed floor, and is 90 deg vertical to level ground.

**Fig. 3**

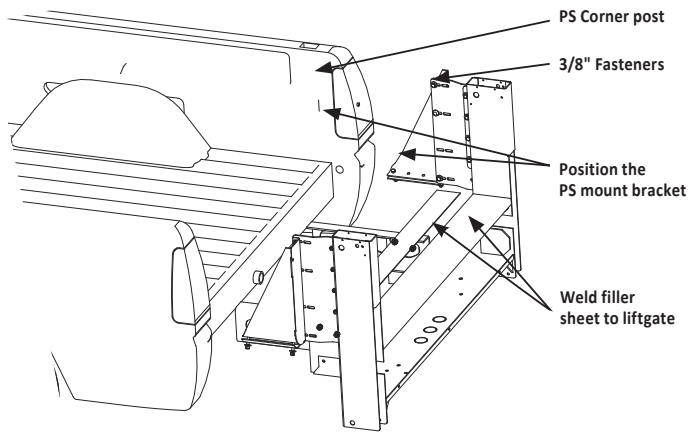

9. Secure three 3/8" x 1" bolts, three flat washers and three locknuts on the mounting bracket.

**Fig. 4**

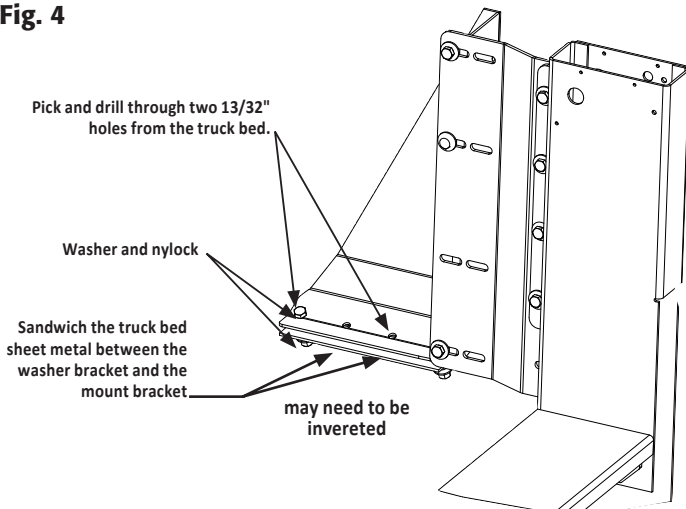

10. Let the liftgate hanging, supported at the bed-posts. Position the racket against the corner post and check for objects of possible interference. Using the bracket as a template, pick two of four holes and drill through the bottom of the bed with a 13/32" drill.

11. Secure each bracket to the truck bed using two 3/8"x1.5" bolts (9), two flat washers, and two nylock nut (11).
12. Align the mounting so the liftgate is straight and level. Tighten the four 3/8 x 1" bolts and four nylock to the liftgate. Use the four washers on the slot side.
13. Using the mounting bracket as a template, find the 3/8 hole toward the bracket and drill a 13/32" hole in the truck corner post. Secure the newly drilled hole with the 3/8 fasteners included.

**Fig. 5**

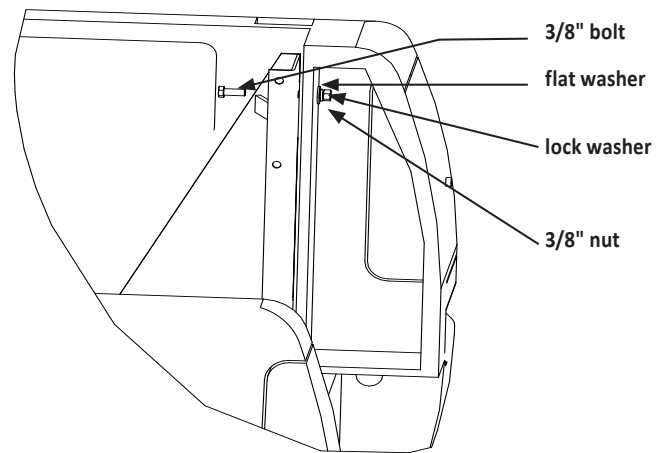

14. Repeat for the Driver Side installation. Re-install tail light lens if it was removed earlier.
15. Verify the spare tire access holes to be available.
  - a. Simply remove the license plate cover and check the existing holes to allow you to get in through the hole.

**Fig. 6**

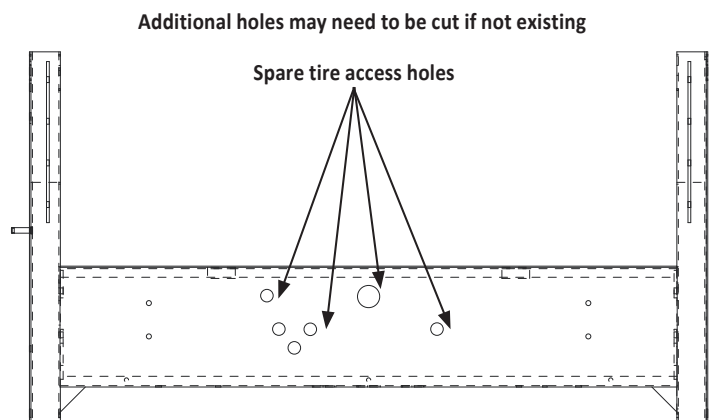

16. Liftgate for wiring.

- a. Remove the 5/16 bolts holding the license cover. Pull out the misc parts bag/box.
- b. Review the Wiring circuit in the figure below.

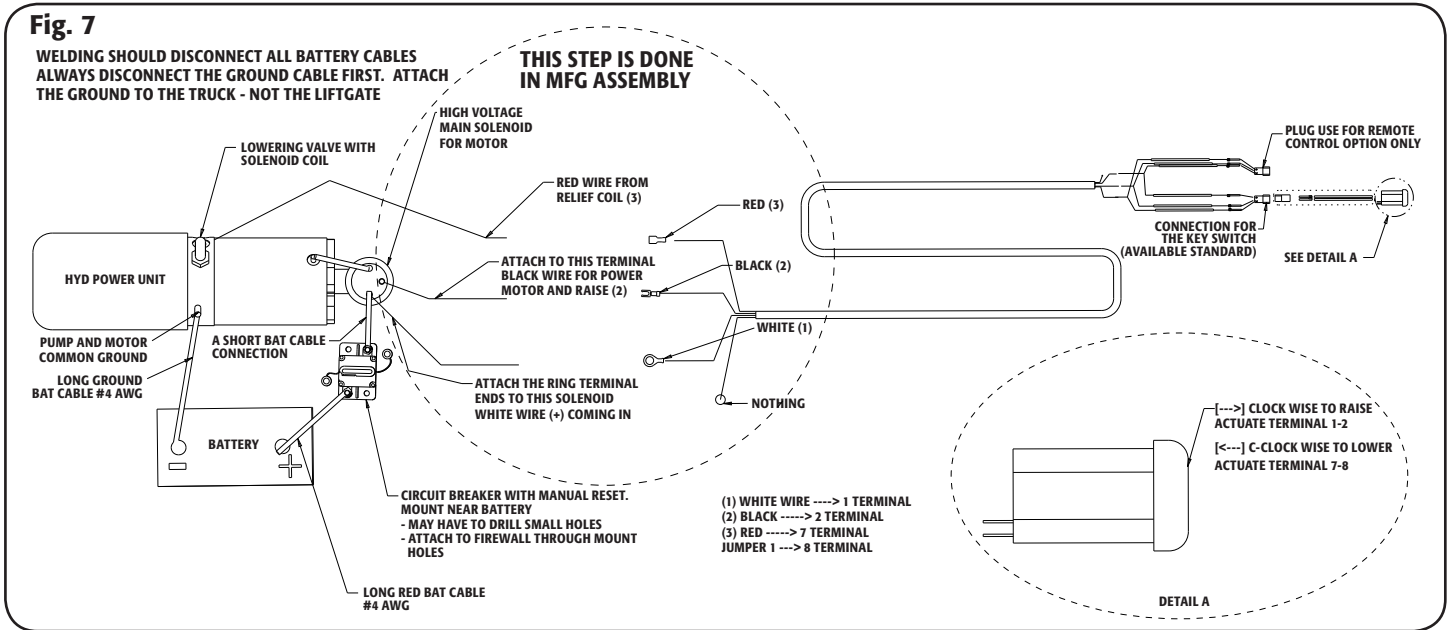

17. Install the circuit breaker on the vehicle fender, firewall or inside the engine compartment away from moving parts [near battery]. Make sure there will be room for the wires to be installed and the reset button is accessible.
18. Loosen the strain relief conduit in the back of the liftgate box. Pull the 4awg wire through the hole-leaving about 2 inches of slack for easy access. Tighten the conduit again.
19. Run the wire underneath the truck and along the frame structure of the truck. Pull the wire beyond the battery location
20. Split the negative and the positive wires to prepare them for attachment to battery.
21. Cut the positive wire length needed to reach the auxiliary terminal of the circuit breaker installed earlier. Cut the remaining positive wire long enough to reach from the breaker to the positive Battery terminal. Cut the negative wire to the needed length to the battery terminal.
22. Install the lower mount onto the frame. Remove the slotted bracket plates from the liftgate. This is located next to the hydraulic unit.
23. Bolt the Bracket plates to the Frame where the holes are available (if not Drill). You may have to do simple modification to the plates.

24. Clamp the short angle irons to the bracket plates. The short angle acting as an extension arm to the slotted angle irons.
25. Tackweld the bracket plates to the short angle irons; and tack weld the short angle iron to the main long angle iron.
26. Remove the tacked brackets by removing the bolts just installed earlier.
27. Weld all seams with a 1/4" fillet weld.
28. Secure the Welded Brackets back onto the truck frame and the bottom of the Lift Gate.
29. Install the license Plate Light onto the cover. Wiring is not provided for this accessory.

**Fig. 8**

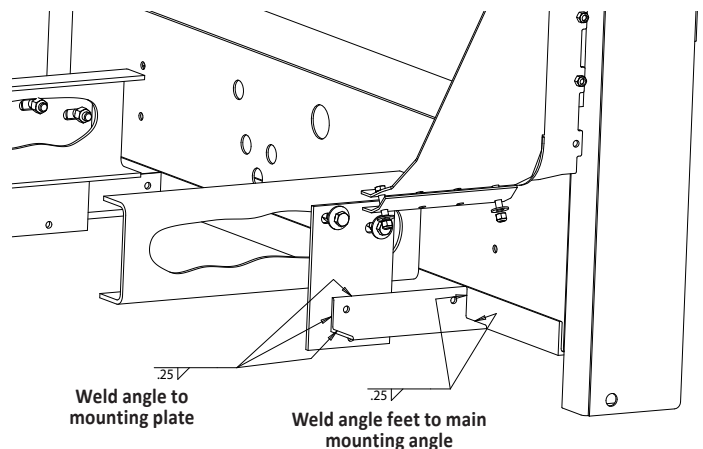

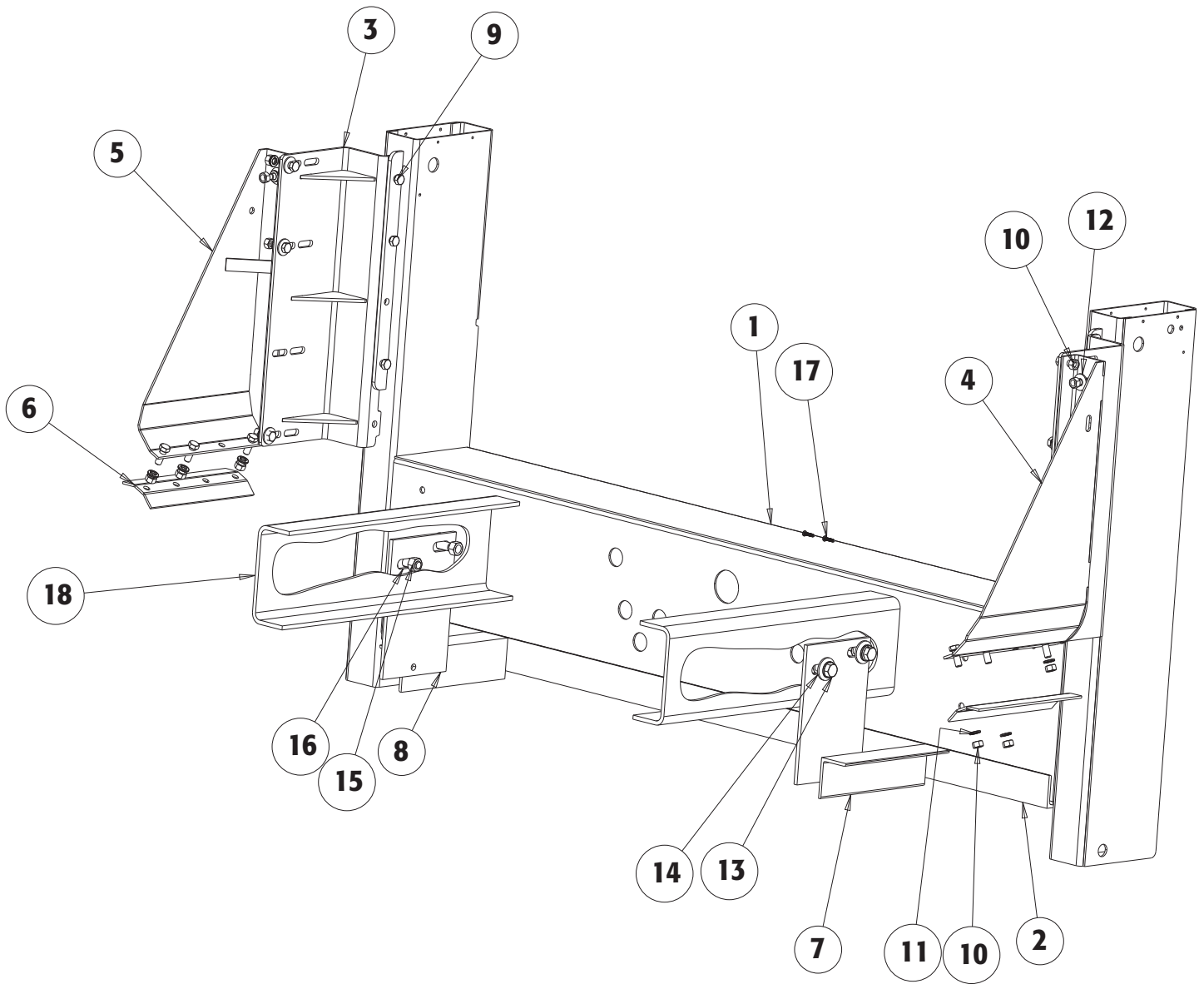

## Parts List

ITEM	PART NO.	QTY.	DESCRIPTION
1	3016802	1	Frame, Upper
2	3016646	1	Angle, Long Mounting
3	3018594	2	Bracket, Anchor Support Weld
4	3018592	1	Anchor, Side Plate Weldment DS
5	3018591	1	Anchor, Side Plate Weldment PS
6	3016641	2	Washer, Bottom Plate
7	3016655	2	Angle, Feet, Mount
8	3016647	2	Plate, Mounting Bottom
9	-	20	Screw, HHC 3/8-16 x 1 GR 5 ZP
10	-	20	Nut, 3/8-16 Hex ZP
11	-	20	Washer, Lock RHS-3/8 SST
12	-	14	Washer, Flat 3/8 USS Zinc
13	-	4	Screw, Hex Head Cap, 1/2-13x1.5, GR5 ZN
14	-	4	Washer, Flat .500 x 1.38 x .14, ZN
15	-	4	Nut, Hex 1/2-13, GR8 PL
16	-	4	Washer, Lock 1/2 Split ZN
17	-	2	Screw Self Tap, 8-32x.75 LG PAN, ZN
18	-	2	Truck Frame, PS & DS