

Toolbox Installation Instructions

Please read these instructions and warnings before installation.

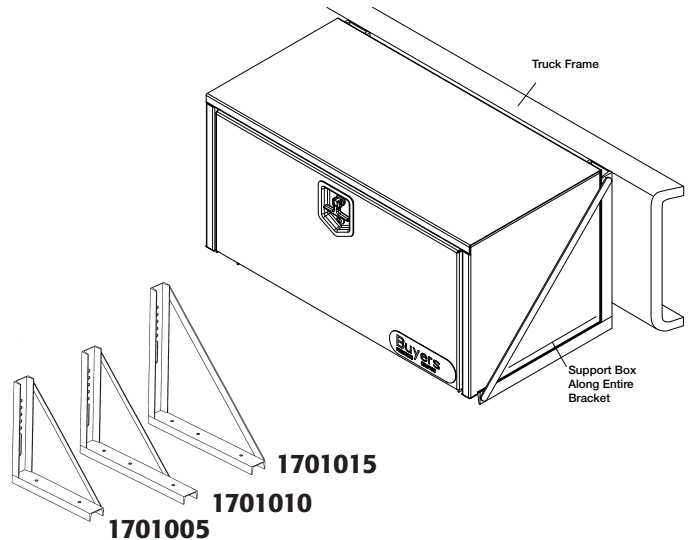
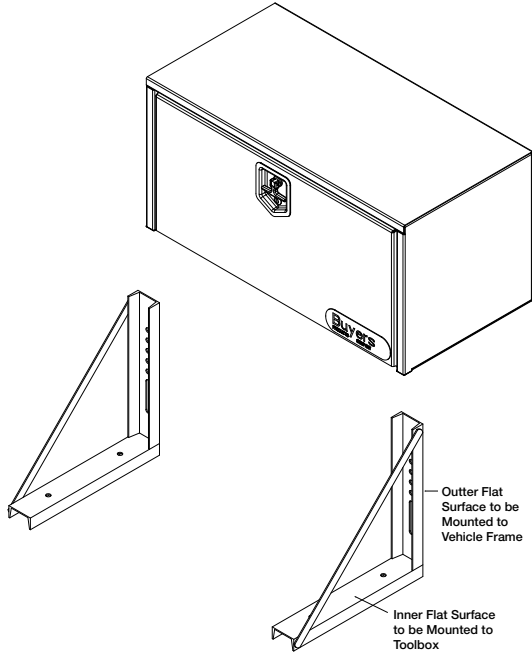

To properly support your Underbody Toolbox, we recommend the use of bottom support mounting brackets. These brackets should be placed so that each end of the toolbox is supported by the full width of the mounting bracket. To prevent rust, touch-up drilled holes with aerosol paint. To prevent water leaks, apply silicone sealant all around each fastener after installation.

DANGER

Do not use this toolbox for the storage or transportation of flammables, explosives, hazardous waste or materials such as gasoline, solvents, gun powder, dynamite, propane tanks, acetylene tanks or cutting torches. This toolbox is only intended and safe for use in storing and transporting small tools and equipment and/or other materials.

WARNING

1. If the proper mounting brackets are not used, the toolbox could drop off the vehicle while it is moving and cause personal injury and/or property damage.
2. Mounting your toolbox through the top, back or sides without bottom support will significantly reduce the capacity and possibly the life of the toolbox.
3. Prior to any welding or drilling holes in a vehicle frame, check for location of fuel tanks, fuel lines, brake lines or electrical wires.
4. If welding is to be done on a vehicle frame in the mounting of this toolbox, disconnect the cables from the battery to prevent shorting of electrical components on the vehicle.
5. Always wear protective eyewear when drilling, welding or checking the underside of a vehicle.

PART NO.	QTY.	DESCRIPTION
1701005	One Pair of	18" x 18" Structural Welded Brackets
1701010	One Pair of	18" x 24" Structural Welded Brackets
1701015	One Pair of	24" x 24" Structural Welded Brackets
1701005B	One Pair of	18" x 18" Structural Bolted Brackets
1701010B	One Pair of	18" x 24" Structural Bolted Brackets
1701006	One Pair of	18" x 18" Formed Welded Brackets
1701011	One Pair of	18" x 24" Formed Welded Brackets
1701016	One Pair of	24" x 24" Formed Welded Brackets
1701006B	One Pair of	18" x 18" Formed Bolted Brackets
1701011B	One Pair of	18" x 24" Formed Bolted Brackets
1701030	One Pair of	18" x 18" Aluminum Brackets
1701040	One Pair of	24" x 24" Aluminum Brackets
1701031	One Pair of	18" x 18" Stainless Brackets
1701041	One Pair of	18" x 24" Stainless Brackets