

Installation Instructions

1316305 Fisher[®] A-Frame Replacement Kit

1. Assemble the A-frame to the blade assembly by inserting the supplied 1" x 6" pivot downward through the blade and A-frame. Secure the pivot pin with the supplied 1/4" x 2" cotter pin.
2. Align the 1" holes in the lower gear assembly with the middle holes of the A-frame push ears and assemble with two old 1" x 3-5/16" pins and 1/4" x 1-1/2" cotter pins. Assemble the pins from the outside towards the inside. Inspect pins before assembly and replace them if they have excessive wear.
3. Reassemble the old angle cylinders and pins.
4. Insert one of the supplied 3/8" U-bolts through the link of the lift chain 32" from an end. Assemble U-bolt and chain to the driver's side of the A-frame using the front two holes. Secure U-bolt with two 3/8" lock washers and nuts supplied. Hook the end of this 32" length of chain into the chain plate on the headgear.
5. Insert other end of the chain through the chain loop on the lift arm from the driver side.
6. Attach the last link of the chain to the front two holes on the passenger's side of the A-frame using the 3/8" U-bolt, washers, and nuts supplied. Make sure that you remove any twists that may be in the chain.
7. Properly attach the plow to the vehicle and verify the chain position by lifting the plow with the 10" travel lift cylinder. The A-frame should hit the headgear just before the cylinder is fully extended. If necessary adjust the lift chain by moving the driver's side U-bolt up or down a link.
8. With the vehicle on a flat surface, lower the plow and check that the A-frame is parallel with the ground. If the A-frame is not parallel with the ground, reposition the A-frame by removing the two pins that connect the A-frame to the headgear and reassemble using the upper or lower A-frame holes. Verify that there is proper clearance for the A-frame to pivot the new position.

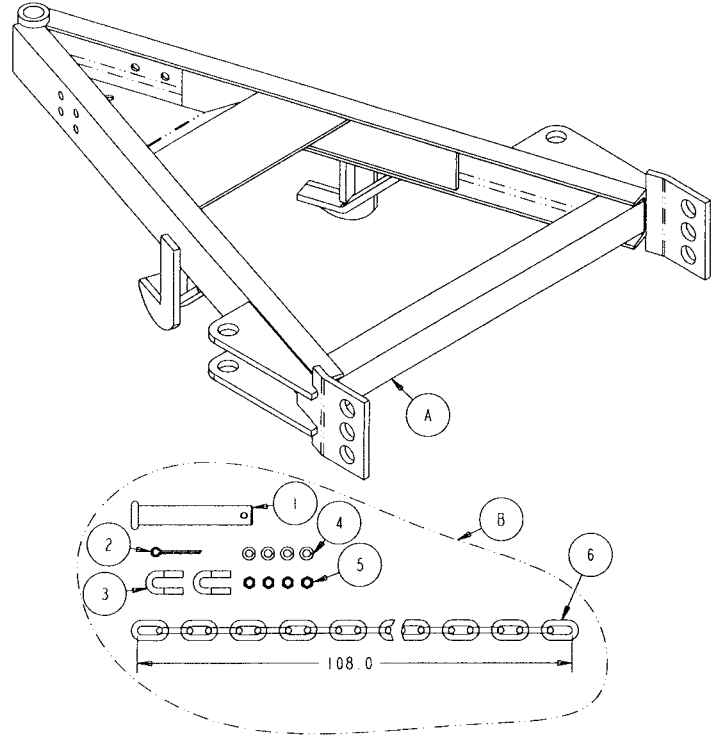

Bill of Materials

ITEM	PART NO.	QTY.	DESCRIPTION
A	1316305A	1	A-Frame Only, Fisher HD L-Series Plow
B	1316305B	1	Hardware Kit, Fisher A-Frame
1	13023501	1	Pin, Pivot 1" x 6" Zinc
2	FPC025000201	1	Pin, Cotter 1/4 x 2 Zinc
3	3006103	2	U-Bolt, Round 1/2 x 1-5/8, 3/8-16 Thd. Zinc
4	FWL038069009	4	Washer, Lock RHS-3/8 Zinc
5	FNH038016028	4	Nut, 3/8-16 Hex Zp
6	3006105	1	Chain, 5/16" x 108", Grade 30 Zy