

3C

FLB Series Circuit Breakers and Enclosures

Cl. I, Div. 1 & 2, Groups C, D
 Cl. II, Div. 1, Groups E, F, G
 Cl. II, Div. 2, Groups F, G
 Cl. III
 NEMA 3, 4, 7CD, 9EFG

Explosionproof
 Dust-Ignitionproof
 Raintight
 Wet Locations
 Watertight

3C

Applications:

FLB circuit breakers and enclosures are used:

- For service entrance, feeder or branch circuit protection for lighting, heating, appliance and motor circuits
- In areas made hazardous due to the presence of flammable vapors, gases or combustible dusts
- In damp, wet or corrosive locations
- Indoors or outdoors at petroleum refineries, chemical and petrochemical plants and other process industry facilities where similar hazards exist
- To provide disconnect means, short circuit protection and thermal time delay overload protection

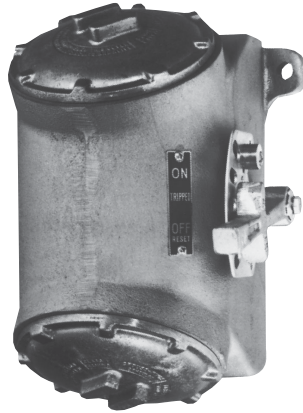

Features:

- Semi-cylindrical body shape for maximum strength at lowest practical weight
- Round threaded covers at each end, set at an angle to provide ready access to interior for ease of wiring
- Breaker is operated by an external handle which can be padlocked in either "ON" or "OFF" positions. Breaker is trip-free of the handle and will open under short circuit or overload even if the handle is locked in the "ON" position
- Bodies have vertical through feed conduit hubs of sizes given in the listings

Certifications and Compliances:

- NEC/CEC
 - Class I, Division 1 & 2, Groups C, D
 - Class II, Division 1, Groups E, F, G
 - Class II, Division 2, Groups F, G
 - Class III
- NEMA/EEMAC: 3, 4, 7CD, 9EFG
- UL Standard: 698
- CSA Standard: C22.2 No. 30

Standard Materials:

- Bodies, covers and operating handles – copper-free aluminum
- Operating shafts – stainless steel
- Interior parts – sheet steel

Standard Finishes:

- Copper-free aluminum – natural
- Stainless steel – natural
- Sheet steel – zinc electroplate with chromate finish

Electrical Rating Ranges:

- 100 and 225 ampere frame sizes

Options:

The following special options are available from factory by adding suffix to Cat. #:

Description	Suffix
2 lugs for neutral connections (50, 100 and 225 amp.)	S146
Ground neutral stud with 3 connectors (50, 100 and 225 amp.)	S168
Standard Breather (Class I, Groups C, D; Class II, Groups E, F, G; Class III)	S219
Standard Drain (Class I, Groups C, D; Class II, Groups E, F, G; Class III)	S198
Standard Breather and Drain (Class I, Groups C, D; Class II, Groups E, F, G; Class III)	S198V
Universal Breather – Drain (Class I, Groups C, D; Class II, Groups F, G)	S454*
(2) Universal Breather – Drains (Class I, Groups C, D; Class II, Groups F, G)	S454V*
Specify Auxiliary Switch†	
1A/1B (1P2T)	S784
2A/2B (2P2T)	S785

Dimensions

In Inches§:

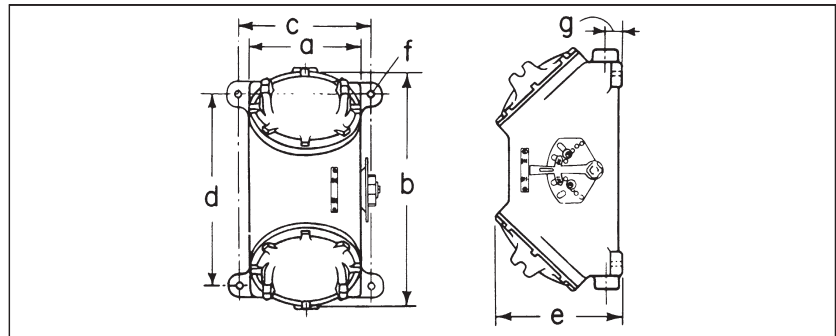

Cat. #	a	b	c	d	e	f	g
†FLB140, 220, 221	5¼	10¼	6¼	7¼	7	7/16	1⅞
FLB115, 141, 147, 148, 171, 172, 173, 175, 222, 361, 116, 142, 149, 174, 177, 223, 362	7½	13⅜	8½	9¾	9⅞	7/16	1¾
FLB224, 225, 264, 265, 267, 346	13¾	22½	16¼	9⅞	15½	21/32	27/16

*Not suitable for NEMA 4/EEMAC.
 †With two mounting feet, one at upper right and one at lower left.
 ‡Application is limited by circuit breaker design – Consult Factory.
 §Dimensions are approximate, not for construction purposes.

FLB Series Circuit Breakers and Enclosures

100A Frame, Thermal Magnetic, 120 VAC/125 VDC, 240 VAC/250 VDC

Cl. I, Div. 1 & 2, Groups C, D
 Cl. II, Div. 1, Groups E, F, G
 Cl. II, Div. 2, Groups F, G
 Cl. III
 NEMA 3, 4, 7CD, 9EFG

Explosionproof
 Dust-Ignitionproof
 Raintight
 Wet Locations
 Watertight

3C

Ordering Information:

To order an enclosure complete with circuit breaker where there is a choice of manufacturer, insert the manufacturer's symbol in the designated position of the catalog number.

Enclosures only can be ordered. Select from listings.

100 Ampere Frame Size with Non-Interchangeable Trip 240VAC Max.

Circuit Breaker		Enclosure								
Poles	Voltage Rating	Hub Size	Circuit Bkr. Amp Rating	Without Circuit Bkr. Cat. #	With Circuit Bkr. General Electric "TEB" Cat. #					
1	120VAC or 125VDC	3/4	15	FLB220	FLB220 TT15 1					
			20		FLB220 TT20 1					
			30		FLB220 TT30 1					
			40		FLB220 TT40 1					
			50		FLB220 TT50 1					
2	240VAC or 125-250VDC	1	15	FLB221	FLB221 TT15 2					
			20		FLB221 TT20 2					
			30		FLB221 TT30 2					
			40		FLB221 TT40 2					
			50		FLB221 TT50 2					
		1 1/2	70	FLB223	90	FLB223 TT70 2				
					100	FLB223 TT90 2				
					3	240VAC	1 1/4	15	FLB222	FLB222 TT15 3
								20		FLB222 TT20 3
								30		FLB222 TT30 3
40	FLB222 TT40 3									
50	FLB222 TT50 3									
1 1/2	70	FLB223	90	FLB223 TT70 3						
			100	FLB223 TT90 3						
			FLB223 TT100 3							

3C

3C

FLB Series Circuit Breakers and Enclosures

**100A Frame, Thermal Magnetic,
120-480 VAC, 125-250 VDC**

Cl. I, Div. 1 & 2, Groups C, D Explosionproof
 Cl. II, Div. 1, Groups E, F, G Dust-Ignitionproof
 Cl. II, Div. 2, Groups F, G Raintight
 Cl. III Wet Locations
 NEMA 3, 4, 7CD, 9EFG Watertight

100 Ampere Frame Size with Non-Interchangeable Trip 480VAC Max.

Circuit Breaker		Enclosure								
Poles	Voltage Rating	Hub Size	Circuit Bkr. Amp Rating	Without Circuit Bkr. Cat. #	With Circuit Bkr. Cutler-Hammer "EHD" Cat. #	With Circuit Breaker General Electric "TED" Cat. #				
2	480VAC or 250VDC	1	15	FLB140	FLB140 WT15 2	FLB140 TT15 2				
			20		FLB140 WT20 2	FLB140 TT20 2				
			30		FLB140 WT30 2	FLB140 TT30 2				
			40		FLB140 WT40 2	FLB140 TT40 2				
			50		FLB140 WT50 2	FLB140 TT50 2				
		1 1/2	70	FLB142	FLB142 WT70 2	FLB142 TT70 2				
			90		FLB142 WT90 2	FLB142 TT90 2				
			100		FLB142 WT100 2	FLB142 TT100 2				
			3		480VAC	1 1/4	15	FLB141	FLB141 WT15 3	FLB141 TT15 3
							20		FLB141 WT20 3	FLB141 TT20 3
30	FLB141 WT30 3	FLB141 TT30 3								
40	FLB141 WT40 3	FLB141 TT40 3								
50	FLB141 WT50 3	FLB141 TT50 3								
1 1/2	70	FLB142	FLB142 WT70 3	FLB142 TT70 3						
	90		FLB142 WT90 3	FLB142 TT90 3						
	100		FLB142 WT100 3	FLB142 TT100 3						

3C

FLB Series Circuit Breakers and Enclosures

100A Frame, Thermal Magnetic, 600 VAC, 250 VDC

Cl. I, Div. 1 & 2, Groups C, D
 Cl. II, Div. 1, Groups E, F, G
 Cl. II, Div. 2, Groups F, G
 Cl. III
 NEMA 3, 4, 7CD, 9EFG

Explosionproof
 Dust-Ignitionproof
 Raintight
 Wet Locations
 Watertight

3C

100 Ampere Frame Size with Non-Interchangeable Trip 600VAC Max.

Circuit Breaker		Enclosure			
Poles	Voltage Rating	Hub Size	Circuit Bkr. Amp Rating	Without Circuit Bkr. Cat. #	With Circuit Bkr. Cutler-Hammer "FDB" Cat. #
2	600VAC or 250VDC	1¼	15	FLB115	FLB115 WT15 2
			20		FLB115 WT20 2
			30		FLB115 WT30 2
			40		FLB115 WT40 2
			50		FLB115 WT50 2
		1½	70	FLB116	FLB116 WT70 2
90	FLB116 WT90 2				
100	FLB116 WT100 2				
3	600VAC	1¼	15	FLB115	FLB115 WT15 3
			20		FLB115 WT20 3
			30		FLB115 WT30 3
			40		FLB115 WT40 3
			50		FLB115 WT50 3
		1½	70	FLB116	FLB116 WT70 3
90	FLB116 WT90 3				
100	FLB116 WT100 3				
Circuit Breaker		Enclosure			
Poles	Voltage Rating	Hub Size	Circuit Bkr. Amp Rating	Without Circuit Bkr. Cat. #	With Circuit Bkr. General Electric "TED" Cat. #
3	600VAC	1¼	15	FLB361	FLB361 TT15 3
			20		FLB361 TT20 3
			30		FLB361 TT30 3
			40		FLB361 TT40 3
			50		FLB361 TT50 3
		1½	70	FLB362	FLB362 TT70 3
90	FLB362 TT90 3				
100	FLB362 TT100 3				

3C

3C

FLB Series Circuit Breakers and Enclosures

225A Frame, Thermal Magnetic,
600 VAC, 250 VDC

Cl. I, Div. 1 & 2, Groups C, D
Cl. II, Div. 1, Groups E, F, G
Cl. II, Div. 2, Groups F, G
Cl. III
NEMA 3, 4, 7CD, 9EFG

Explosionproof
Dust-Ignitionproof
Raintight
Wet Locations
Watertight

100 Ampere Frame Size with Non-Interchangeable Trip 600VAC Max.

Circuit Breaker		Enclosure			
Poles	Voltage Rating	Hub Size	Circuit Bkr. Amp Rating	Without Circuit Bkr. Cat. #	With Circuit Bkr. Cutler-Hammer "JDB"† Cat. #
2	600VAC or 250VDC	2½	125	FLB264	FLB264 WT125 2
			150		FLB264 WT150 2
			175		FLB264 WT175 2
			200		FLB264 WT200 2
			225		FLB264 WT225 2
3	600VAC	2½	125	FLB264	FLB264 WT125 3
			150		FLB264 WT150 3
			175		FLB264 WT175 3
			200		FLB264 WT200 3
			225		FLB264 WT225 3
3	600VAC	2½	125	FLB224 or FLB346	FLB224 TT125 3
			150		FLB224 TT150 3
			175		FLB224 TT175 3
			200		FLB224 TT200 3
			225		FLB224 TT225 3

100 Ampere Frame Size with Interchangeable Trip 600VAC Max.

Circuit Breaker		Enclosure				
Poles	Voltage Rating	Hub Size	Circuit Bkr. Amp Rating	Without Circuit Bkr. Cat. #	With Circuit Bkr. Cutler-Hammer "JD"* Cat. #	With Circuit Bkr. General Electric "TFK" Cat. #
2	600VAC or 250VDC	3	125	FLB267	FLB267 WT125 2	
			150		FLB267 WT150 2	
			175		FLB267 WT175 2	
			200		FLB267 WT200 2	
			225		FLB267 WT225 2	
3	600VAC	3	125	FLB267 or FLB225	FLB267 WT125 3	FLB225 TT125 3
			150		FLB267 WT150 3	FLB225 TT150 3
			175		FLB267 WT175 3	FLB225 TT175 3
			200		FLB267 WT200 3	FLB225 TT200 3
			225		FLB267 WT225 3	FLB225 TT225 3

*Formerly "KB"
†Formerly "JB"