



Jeep® Wrangler 2007-2018 Trail Armor™ Fastback Top 2 Door (JK) 14935

STEP 1 – PRIOR TO INSTALLATION

- A)** Bushwacker only approves installing the soft top according to these written instructions with the hardware provided. **WARNING:** Failure to install according to these instructions will invalidate the warranty. This includes, but is not limited to using alternative installation methods, hardware, or materials. For correct installation of the top in warm weather is optimal for ease of installation. Temperature should not be less than 70° (21C). Initial installation is the most difficult as the fabric has not been stretched. The top will loosen slightly with use and warm temperature.
- B) Care & Cleaning:** Bushwacker soft tops are built to last; Washing: The soft top fabric should be washed often using a mild soap, warm water and a soft bristle brush (do not use the brush on the window glass!). You can also use special soft top cleaners. Make sure that after cleaning you rinse with clear water to remove all traces of soap.
- C) Windows:** It is very important that you keep your windows clean! Use a mild soap and water solution to gently clean your windows. NEVER wipe your windows clean with a dry cloth! Dust and dirt on a dry cloth can scratch your windows causing “fogging” and permanent damage. When removing your windows, store them in the window storage bag provided. Do not use any chemical cleaners of any kind on glass.
- D) Pre-Installation requirements**
Remove existing hard or soft top and all original hardware on your Jeep Wrangler.











Set Part #BWT-14935

TOOLS FOR EASY INSTALLATION:

- Phillips Screwdriver
- Ratchet and Extensions
- Torx Bits
- Allen Wrench
- Small bolt driver
- Safety Glasses

Trail Armor Soft Top™

Included in Hardware Kit:

- | | | | | |
|---|---|---|---|---|
| 1. | 2. | 3. | 4. | 5. |
|  |  |  |  |  |
| Main Deck Fabric w/window storage bag
1 pcs | LH Rear Quarter Windows
1 pcs | RH Rear Quarter Windows
1 pcs | Back Window
1 pcs | Hinge Plate LH
1 pcs |
| 6. | 7. | 8. | 9. | 10. |
|  |  |  |  |  |
| Hinge Plate RH
1 pcs | Retainer Tailgate Plastic
2 pcs | Tailgate bar
1 pcs | Self Tap Screw
22 pcs | Shoulder Bolt
4 pcs |

Contents cont.

11.



Flip top hardware
1 pcs

12.



LH Upright Horizontal
1 pcs

13.



RH Upright Horizontal
1 pcs

14.



LH Vert Upright
1 pcs

15.



RH Vert Upright
1 pcs

16.



LH Upper Corner Plastic
1 pcs

17.



RH Upper Corner Plastic
1 pcs

18.



LH Corner Side Window
1 pcs

19.



RH Corner Side Window
1 pcs

20.



Door Surround Bracket
Rear 2 pcs

21.



Upright Turn Knob
2 pcs

22.



Top Retention Strap
1 pcs

23.



Nut 4 pcs

24.



Door Surround Knob
Long,Med,Short 6 pcs

25.



Front Latch 2 pcs

26.



Door Surround Bracket
Front 2 pcs

27.



Strap Hardware
1 pcs



NEVER OPEN UP OR CLOSE YOUR SOFT TOP ROOF WHILE DRIVING OR WHILE THE VEHICLE IS MOVING. SERIOUS DAMAGE TO YOUR VEHICLE AND SOFT TOP CAN OCCUR! ALWAYS PULL OFF THE ROAD IN A SAFE AREA, COME TO A COMPLETE STOP AND PUT THE VEHICLE IN PARK BEFORE ATTEMPTING TO FOLD BACK OR RE-SECURE YOUR SOFT TOP.

Installation Procedures:

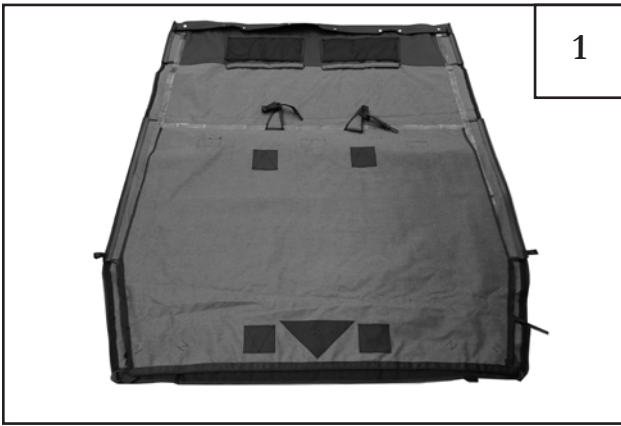

Unfold your new Soft Top and separate the packaged pieces.

TIP: Door Surround frame pieces are marked with L for left side (Driver Side) on plastic packaging. Passenger's side pieces marked with R for right side. Set aside the windows for a later step and take care not to scratch them.

TIP: The factory door surrounds cannot be used. Use the door surround supplied in the kit that has been designed specifically for the Trail Armor Soft Top™.



Assemble door surround by inserting the front extrusion bar into the corner upper horizontal part pre-assembly as shown.

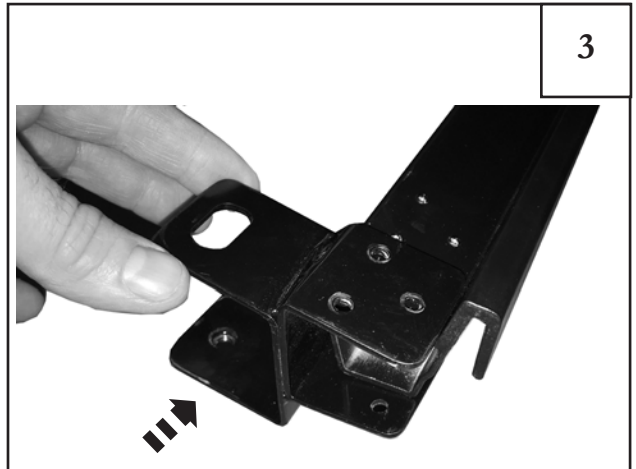

Install rear bracket to rear end of rear extrusion bar by sliding over to line up holes as shown. Do not screw at this time.

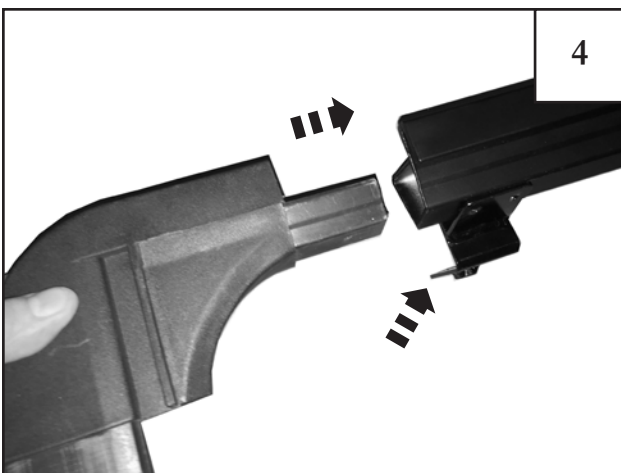

With bracket in place insert the plastic corner into the rear extrusion.

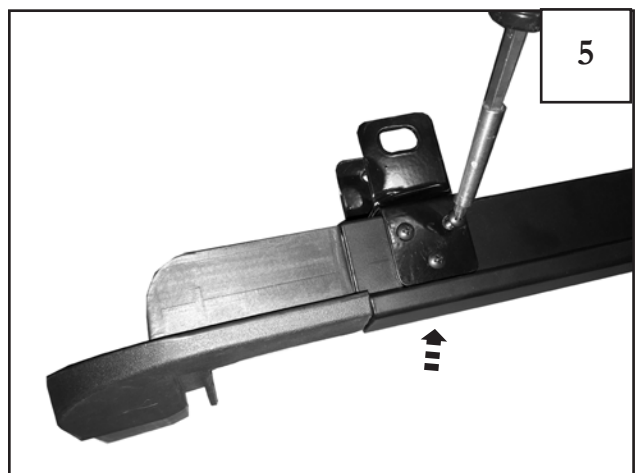

Using a 3 screws tighten into plastic corner part and rear bracket as shown.

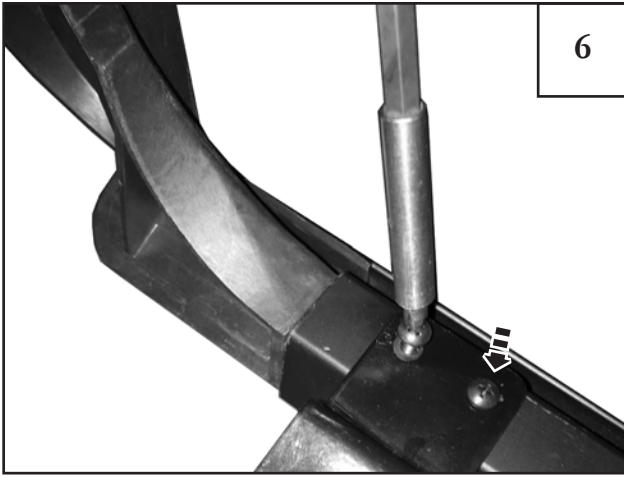

Rotate door surround over to access the bottom side. With 2 screws tighten them into plastic corner part as shown.

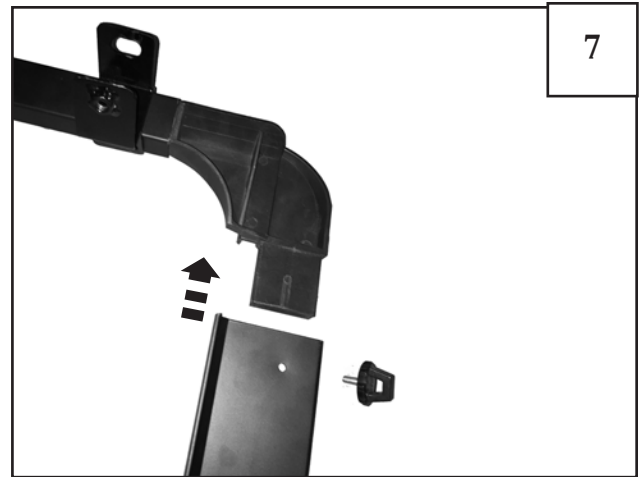

Insert the other end of the plastic corner part into the vertical extrusion part and secure with the turn knob screw.



Install and secure with the turn knob screw as shown.

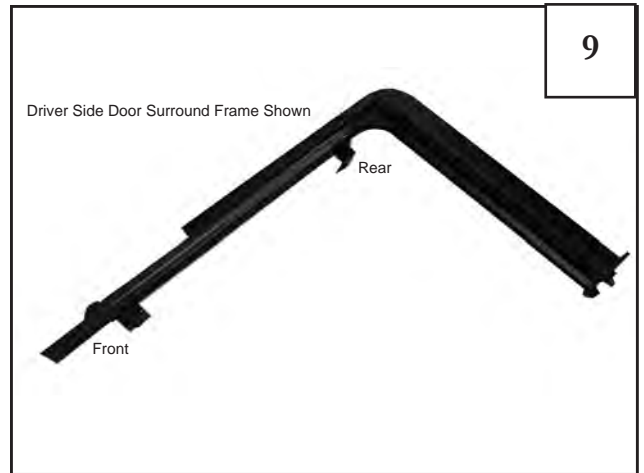

The door surround assembly is now complete. Repeat these steps (steps 2-9 to assemble the other door surround frame).

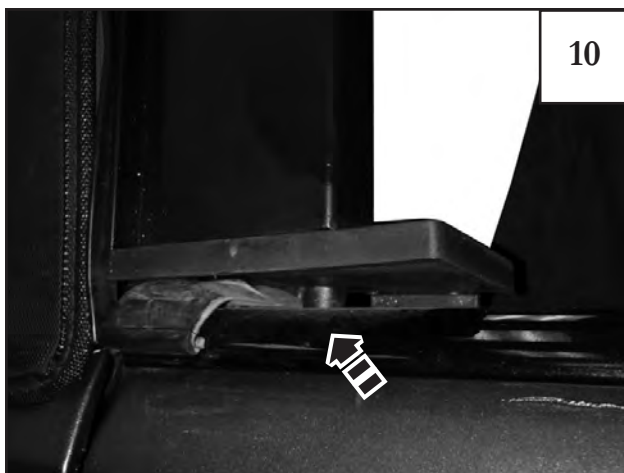

Position completed door surround onto the vehicle and fit the bottom base pin into the hole in vehicle tub near the rear door latch.



Position door surround rear bracket onto the vehicle and fit the bracket over the sport bar.

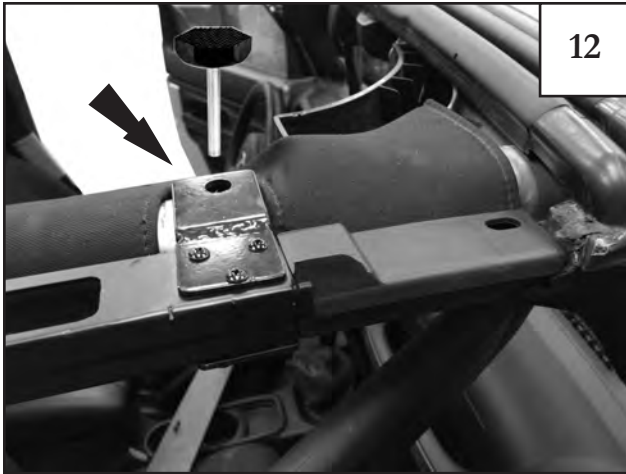

Position door surround front bracket onto the vehicle and fit the bracket over the sport bar sport bar.

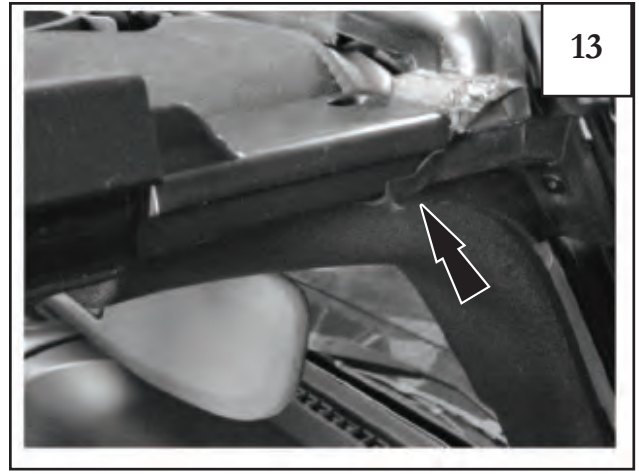

TIP: Make sure the rubber gasket at the top of the windshield is correctly sealed against the front door surround section. See photo for proper fit and check that the factory foam seal is in place.



Place driver side mount plate on top completed door surround onto the vehicle and fit the bracket over the roll bar. Line up front hole to the front bracket door surround. Repeat this step for both sides.

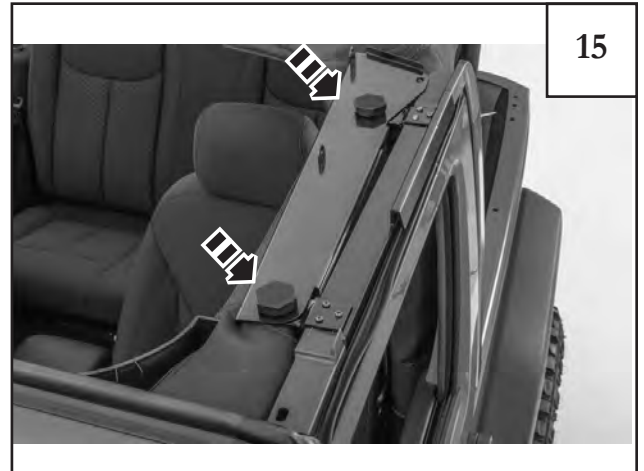

Starting at the front bracket hole insert door surround knob into hole and tighten. Repeat step 14-15 for other side.



Fit top retention strap to door surround mount plate hole located at rear. Locate the unused hole on the back of door surround plate as shown. Note: There is only one strap and it is installed on the driver side.



Put the retention strap in place with the bolt through the grommet as shown. Next, install the 2nd washer and Nylock nut on top of the strap and tighten with 13mm socket wrench and 13mm wrench.



18

When the top is in the folded back position reach up and hook the retention strap over the bar as shown. **Note: The strap is used to safely secure the soft top in the open position at high speeds.**



19

Make sure to unhook the retention strap from the bar before folding the top forward again.



20

Use a Torx T25 bit to remove both the footman loop from the windshield on both the driver's and passenger's side as shown.



21

Install provided latch as shown and reattach with the Torx T25 bolt from the previous step.



22

Place the soft top hardware tubes assembly on top of the main deck fabric then insert into the front pocket. Secure with snaps as shown. **Tip: Place front metal into corner pockets and pull all the way until it fits snug.**

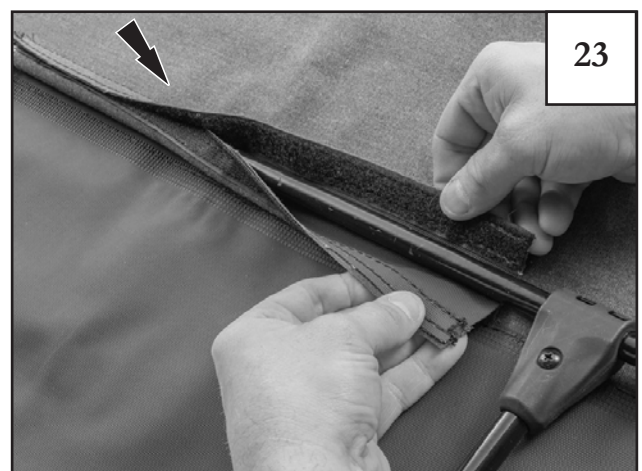

23

Secure the Flip Top tube to the Soft Top main deck by engaging the Hook and Loop flaps as shown on both sides.

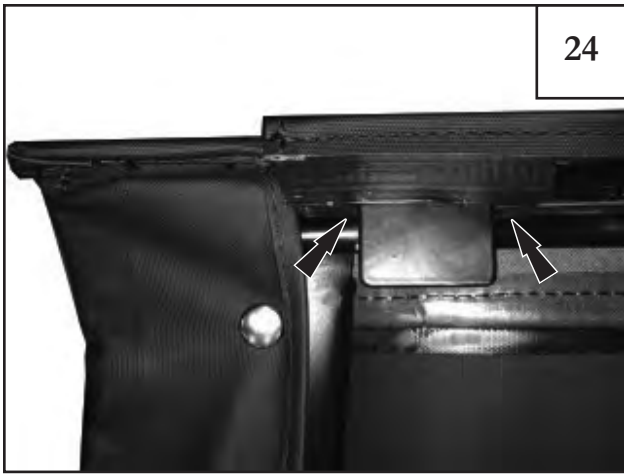

24

Tuck the plastic strip into square metal part as shown for proper fit as shown both sides.

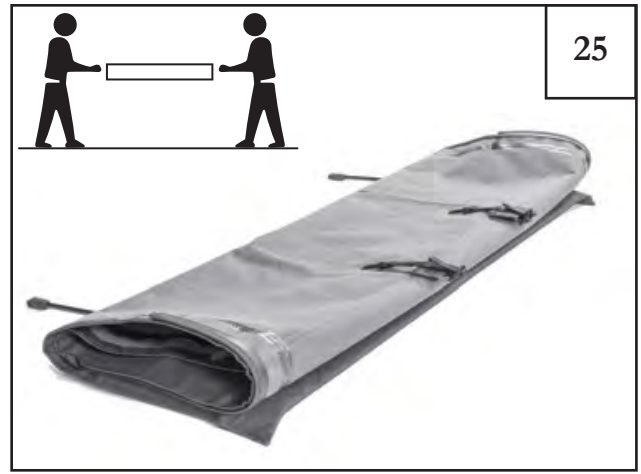

25

TIP: Place the top face down and re-fold, beginning with the rear window portion. It may be helpful to have a second person for this step.



26

Lift the folded soft top and hardware assembly onto the top of the Wrangler sport bar. Place and center toward the front windshield gasket and line up 4 pivot point clamps as shown.



27

Using the supplied 4mm Allen key, install the Shoulder Bolts from the outside of each soft top header assembly knuckle and tighten each bolt with a lock nut 4 places. The lock nut will fit into plastic.

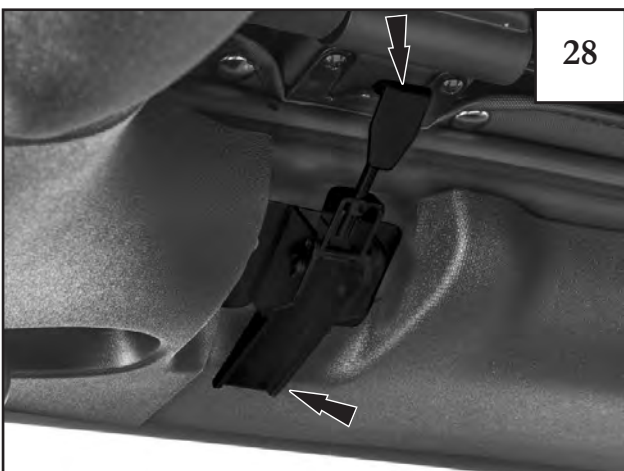

28

Pull the flip top header assembly tightly against the windshield seal and hook to catch. For proper tight adjustment of the latches, unscrew each front screw hook latch where the latching hook just reaches the header assembly.



29

Closed and secure the front latches as shown on both sides at this time.



Un-Fold the soft top over the sport bar frame working toward the rear of vehicle.



Wrap the two straps attached to the middle section of fabric around the rear-middle of the sound bar.



Insert plastic hooks into the holes on the underside of the sound bar. Tighten the strap until snug then hook and loop. **TIP: If soft top appear loose on top these can be pulled tighter for tight soft top.**



Locate the long strap at the rear corner of the main deck. Pull it straight and to the outside of the sport bar.

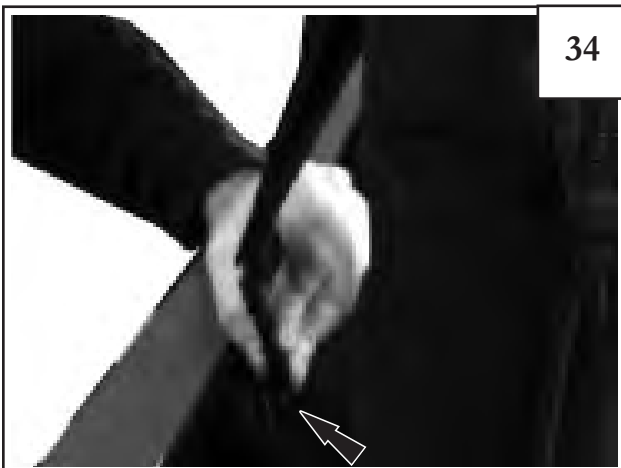

Pull the hook straight and to under inside of the metal tub belt rail.



Pull strap tight and repeat on the other side as shown.



36

Check to see the top is centered, the support bar should show over the zippers on the roll bar pads equally left and right as shown above.

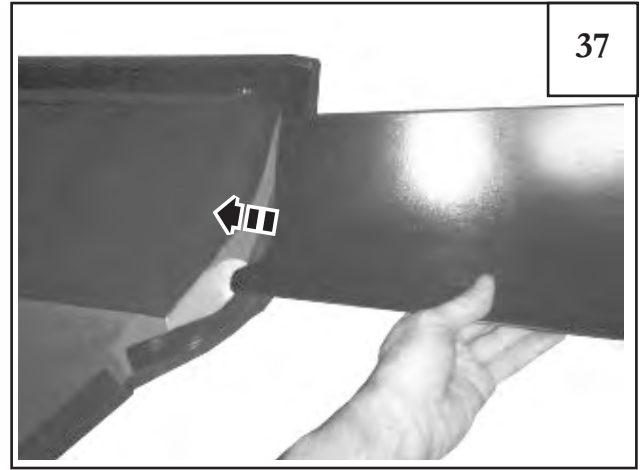

37

Window preparation: Insert the black plastic corner insert into the fabric sleeve-pocket located inside your rear qtr window. Repeat to both sides.



38

Insert all the way to the top as shown here.



39

Lift plastic guards up so that corner piece will be under.

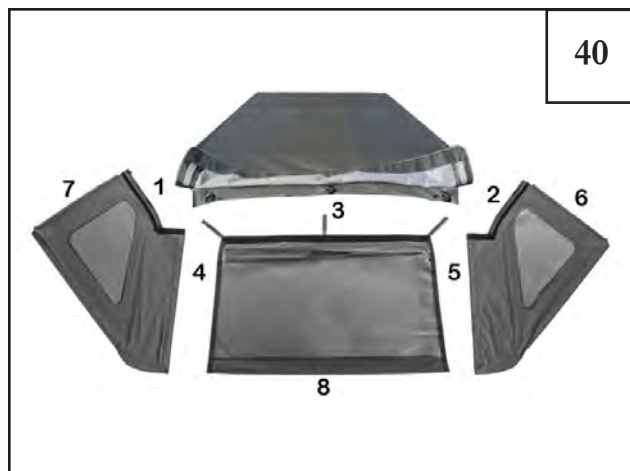

40

Window Installation Order: **1,2** Attach zippers to main deck. **3** Attach Rear window straps. **4,5** Zip rear qtr windows to the rear window. **6,7** Plastic strip into door surround. **8** Tailgate bar bottom rear window.



41

1,2 Secure the side windows to the main deck fabric by zipping into place. **TIP: Only zip them approximately 6" short of the end.** Repeat for the other side and leave parts loose at this time.

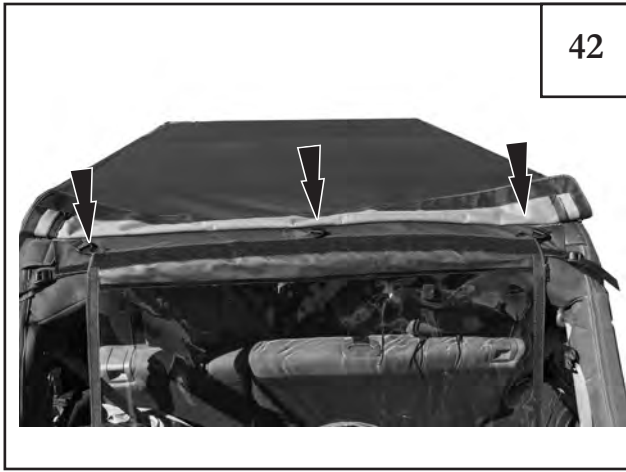

42

3 Secure the rear window to the main cover fabric with 3 straps into place as shown.



43

3 Secure the rear window to the main cover fabric with straps into place as shown. Leave Parts loose at this time.



44

3 Secure the rear window to the main cover fabric with straps into place as shown. Leave Parts loose at this time.



45

4,5 Zip qtr windows to rear window and repeat for the passenger side windows evenly as shown above. **TIP: Once the rear zippers are started then go back to side qtr window top and close zipper all the way to end [Step 42]. Tuck 6,7 into belt rail.**



46

6,7 Tuck the verticl plastic on the qtr windows into door surround by placing it into the vertical door surround lip as shown. **TIP: Start at the top corner to tuck plastic edge into the track in the door surround.**



47

8 Slide the tailgate bar onto the bottom of the rear window, using the built-in C-channel to guide it over the the flap and small tube.

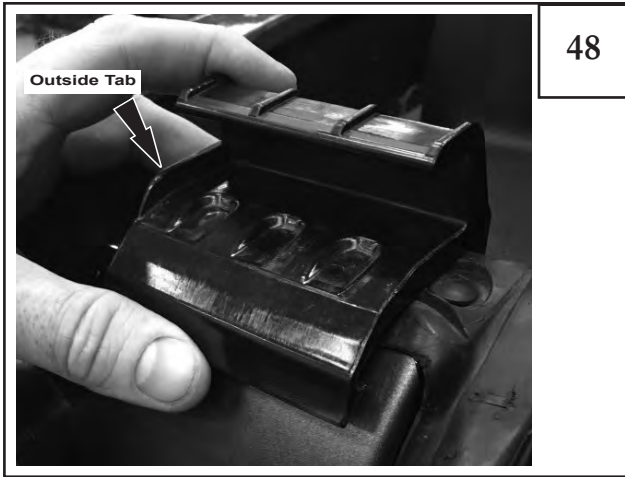

48

Installed position. Tab goes to outside of vehicle. Driver side is shown.

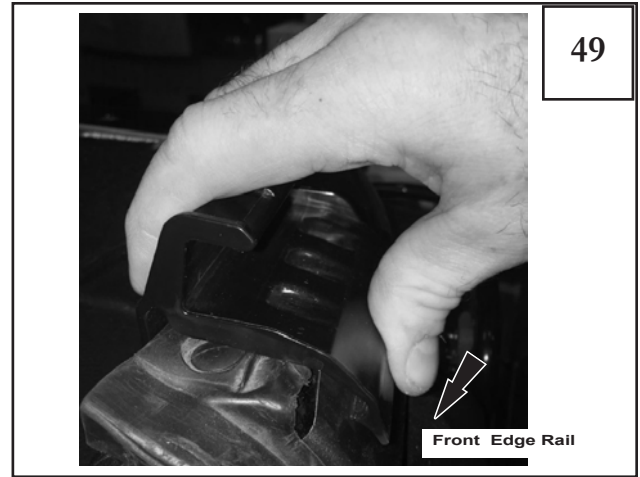

49

Close the clamp with downward pressure front edge over the belt rail sheet metal. The clamp will snap and lock onto the underside of the tube edge.

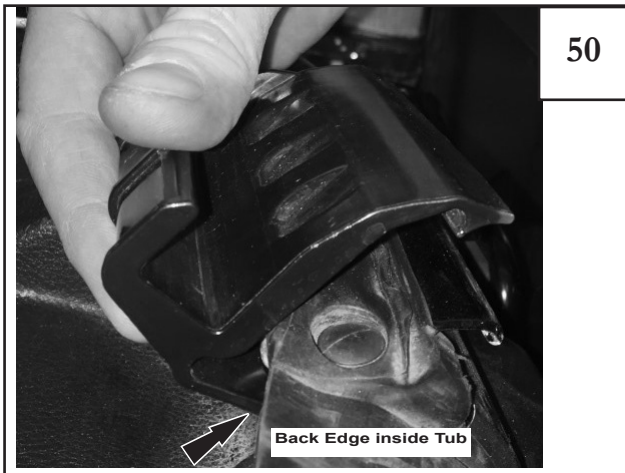

50

Install the retainer tailgate bar holder by hooking the back edge of retainer to the inside tub. Close the clamp with downward pressure front edge over the belt rail sheet metal.



51

Tighten all straps and close the hook and loop flaps down and sealed on rear window as shown.

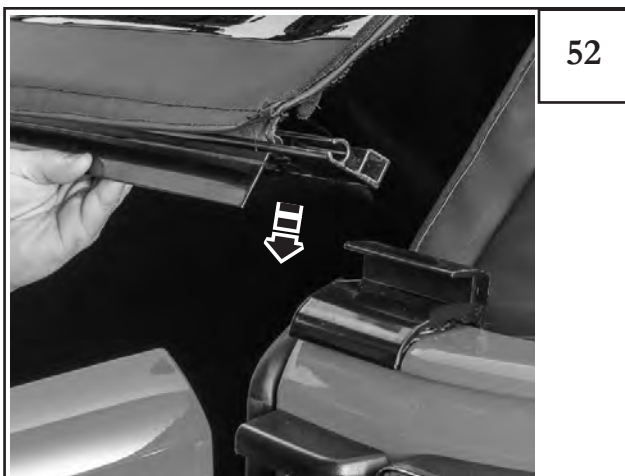

52

Grab the rear window tailgate bar with 2 hands and place into retainer clips as shown. Tip: Be sure bar is centered equally side to side. And then with rotating downward it will lock into place.



53

Close rear window zippers. Zip rear window closed in small amounts, approximately 2-4" at a time, going side to side until complete.

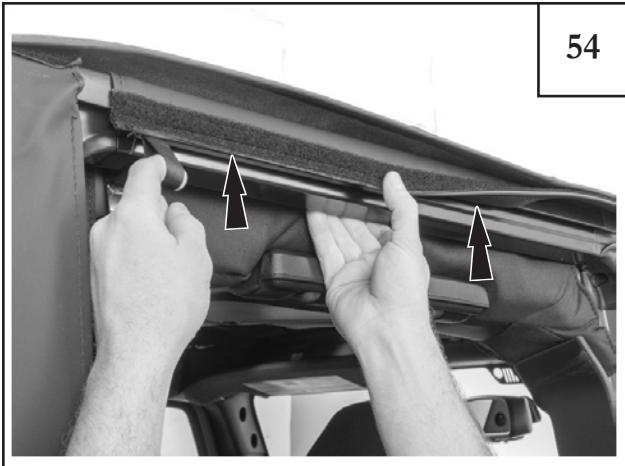

54

Install main deck plastic tuck strip into door surrounds. After plastic is tucked in then the flap portion hook & loop needs to be closed to the door surrounds.



55

Slide lower rear qtr window channel into body tub rail as shown.



56

Work your way around the corners of the rear window. Starting from the side.



57

Clip in the last portion of window corner under the rear window retainers as shown.

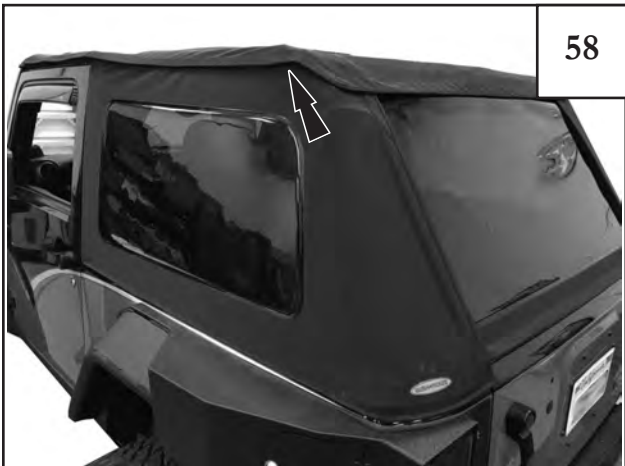

58

The installation of the soft top is now complete. Be sure all hook and loop flaps are closed.



59

The following Steps show the use after installation. With your vehicle completely stopped engaged in park and in safe area, unlatch the two front latches. Undo the hook & loop side strips attached to the upper door surrounds.



60

Grab the Flip Top Center Grab Handle and push up. The frame will pivot towards the back of the vehicle and rest on itself.



61

Once the soft top is open remember to attach retention strap for speed over 55mph [Refer to Step 19].



62

While open, the soft top fabric will rest on the top deck above the sound bar, allowing you to enjoy the open air top experience! Attach retention strap to frame [See Step 18].



63

After removal of all windows, they can be stored in the provided soft top window storage bag between the two layers in the rear portion of the main deck.



64

To close, stop the vehicle, pull off the road in a safe area and put the vehicle in park. Remove retention strap and lift the center grab handle and push up. The frame will pivot towards the front of the Jeep. Latch both windshield latches and re-attach the hook & loop fasteners on the door surrounds.



65

Enjoy your **Bushwacker Trail Armor Soft Top™!**

Learn more about soft tops and hard tops we have.